

- New Barry Controls range
- New STRASONIC® acoustic range
- New S.L.F.® mount



@gotrading



GreatOrientalTrading



097-3619703



FLEXIBLE MOUNTINGS

PAULSTRA



HUTCHINSON®
WORLDWIDE



FLEXIBLE MOUNTINGS

CONTENTS

	Page
I - INTRODUCTION	3
II - DEFINITIONS	
II.1 Flexible Mountings	4
II.2 Flexible Mounting Systems	5
III - FUNCTION OF A FLEXIBLE MOUNTING SYSTEM	
III.1 Static function	9
III.2 Dynamic function	9
III.3 Various types of flexible mounting systems	17
IV - DESIGNING A FLEXIBLE MOUNTING SYSTEM	
IV.1 Determining the centre of gravity	19
IV.2 Determining the load per mounting	21
IV.3 Determining the deflection	23
IV.4 Design examples	24
V - PAULSTRA RANGE	
Mountings selection guide	30
Mountings application guide	32
RADIAFLEX	34
PAULSTRADYN	38
STABIFLEX	42
STABIFIX	45
TRIAXDYN	47
ENGINE MOUNTINGS	49
S.C. MOUNTINGS	51
EVIDGOM	55
S.T.C.	58
STOPS	60
NIVOFIX	65
MINIFIX	67
TRAXIFLEX	68
BATRA RING	70
BECA	72
POLYFLEX	75
S.C.P. MOUNTINGS	76
ISOFLEX	77
ISODYNE	79
S.L.F. MOUNTS	81
SANDWICH MOUNTINGS	82
ELIGO	85
SUPPORTS AND BUMP STOPS	86
OTHER MOUNTINGS	89
Long Travel AIR SPRING	97
HEAVY DUTY FENDERS	99
STRASONIC RANGE	102
Index	104
VI - VIBRACHOC RANGE	
Mounting application guide	112
E1V3245-04 to E1V4059-11	88
VIBMAR	114
TYPE X	118
ARDAMP	119
E1C2321/E1T2105	122
ELASTOMER MOULDED PARTS	125
ELASTOMER PLATES	128
E1E11/E1E12/E1E13	129
E1E21/E1E22/E1E23	131
E1E31/E1E32	132
E1E41/E1E42/E1E43	133
Index	134
VI - BARRY CONTROLS RANGE	
PNEUMATIC MOUNTING SLM	136
MOUNTING 22000	139
CUPMOUNT	143
RINGS AND BUSHINGS	146
FLEX6LOC	149
GB530	151
Index	152

See current price list for availability of items.
We reserve the right to modify the design and manufacture of the products and materials described in this catalogue.

The pictures of the products are supplied for information only.

The order comprises :

- the contract signed by both parties, or the purchase order and the acknowledgement of receipt,
- eventually, special or specific additional conditions,
- sale general conditions, available upon request are part of the order.

FLEXIBLE MOUNTINGS

I - INTRODUCTION

The **reduction of noise and vibration** has become very important :

- The need to improve conditions makes it essential.
- The increasing mechanisation of industrial and domestic activities make it necessary.
- The lightness and increasing complexity of equipment demand it.

The following pages are dedicated to protection against vibrations and shock. They offer design engineers the means to resolve isolation problems using elastomer alone or elastomer bonded to metal supports.

The first few pages start, therefore, with a summary of definitions and an explanation of the terminology used as well as the principal formulae on which suspension calculations are based. The design of a flexible mounting system is a major undertaking and is the subject of a special section which gives the principles used to select a mounting according to its size, characteristics, type and applications.

Warning : solving flexible mounting system problems very often requires the services of a specialist and we advise, very strongly, that if a simple solution cannot be found, then our Technical Services should be consulted.



II - DEFINITIONS

II.1 - FLEXIBLE MOUNTINGS

II.1.1 - Properties

- Flexible mountings are components which exhibit both flexibility and damping, at the same time and to varying degrees.

- **Flexibility**

- Flexibility is the ability of the mounting to deform and recover, with an amplitude approximately proportional to the load.

- **Damping**

Damping is a braking force the most important effect of which is the reduction of oscillations.

There are essentially two types of damping :

- Constant friction (dry friction) which, for a given setting, provides a constant braking force independent of the movement. For there to be movement, it is, therefore, necessary to apply a force at least as great as the frictional force.

- Viscous damping (such as that provided by hydraulic dampers) which provides a braking force proportional to the instantaneous velocity of the suspended part relative to the fixed part. Viscous damping is, therefore, essentially dynamic : it does not affect the position of static equilibrium.

II.1.2 - Environmental conditions

Most of the standard mountings are made of natural rubber which has been chosen because of its good dynamic properties.

Under normal operating conditions, these rubber compounds guarantee stability over long periods and, in particular, limited creep.

The following operating conditions are considered abnormal :

- temperatures greater than 70°C,
- prolonged contact with corrosive liquids,
- prolonged contact with acids or alkalis,
- aggressive environment (oils, fuels),
- corrosive gases (ozone, chlorine...).

Using a mounting unintentionally under such conditions can lead to premature ageing, degradation or even destruction of the rubber.

An abnormally aggressive environment can, in particular, increase the deformation of the mounting (creep).

PAULSTRA flexible mountings may be made using various special compounds that are highly resistant and able to withstand the abnormal conditions described above.

Our Technical Services are at your disposal to reply to any queries about the properties of particular compounds.

II.1.3 - Elastomeric flexible mountings

Mountings using natural or synthetic elastomers always provide a combination of pure elasticity and viscous damping. Although commonly used, the term "shock absorbers" is completely incorrect. The two characteristics, flexibility and damping, are, in fact, essentially different : a rubber mounting may be compared to a car suspension where the two functions are provided by different components working in parallel :

- true elastic suspension provided by springs,
- damping provided by hydraulic damping (shock absorbers).

A flexible mounting using rubber = a spring + a damper.

II.1.4 - Characteristics of elastomeric flexible mountings

• Elastic properties

These are the parameters which define the ability of the mounting to be deformed in various directions.

- **The linear stiffness K_x** , along the axis G_x is the ratio of the force to the corresponding displacement along this axis. The linear stiffness is expressed by daN/mm.

The linear stiffness (K_y, K_z) for the other axes (G_y, G_z) are defined in the same way.

- **The torsional stiffness (C_x, C_y, C_z)** about the three axes (G_x, G_y, G_z) is the ratio of the torque to the angular displacement about the axis.

The torsional stiffness is expressed in m.daN/rad.

These six parameters, which are not independent of each other for a given mounting (the interdependence changes with the shape and structure of the mounting) are proportional to the Young's modulus of the elastomer used in the mounting.

Using these six values, it is possible to calculate the stiffness along or about any arbitrary axis.

• Damping properties

The most useful parameter is the "intrinsic damping factor" of the elastomer used. This will be defined for a suspension (§ II.2.2). The intrinsic damping factor of a mounting is the same as that of the suspension.

II.2 - FLEXIBLE MOUNTING SYSTEMS

A machine is suspended elastically by placing flexible mountings between the machine and its seatings (floor, slab, chassis, etc.). The type of mounting, its number, distribution, positioning and individual characteristics, depend on the overall characteristics required by the suspension to give the desired result.

The most common problems are those where vibration determines the essential characteristics of the suspension. It is necessary, therefore, to start with a presentation of the terminology and a review of the most important definitions and principles.

II.2.1 - Vibration theory concepts

A machine, suspended elastically, vibrates when it is subject to periodic alternate influences which produce oscillations of greater or lesser amplitude.

There are two main modes of vibration :

- Natural or free vibration, which is the vibration of the machine that occurs when it is released after having been displaced from its position of equilibrium,
- Forced vibration, which is imposed on the machine, either by its own operation, or by influences from its surrounding.

• Degrees of freedom

The number of degrees of freedom is the number of independent parameters which determine the position of the machine at any given time.

Degrees of freedom of movement :

- Linear movement parallel to a given axis (the independent parameter is the displacement along the axis),
- Rotation about a given axis (the independent parameter is the angle of rotation about the axis).

• Vibrations with only one degree of freedom

The following discussion applies to vibrations with only one degree of freedom : a linear vibration parallel to a fixed axis.

• Periodic vibration :

- Frequency : Number of complete cycles in a unit of time.

N = Number of cycles per minute.

n = Number of cycles per second (Hertz).

- Period : Duration of one cycle.

$$T = \frac{1}{n} \text{ (seconds)}$$

- Angular frequency : $\omega = 2\pi n = \frac{2\pi}{T}$ (radians per second).

- Maximum amplitude: The maximum offset from the equilibrium position for each cycle. For a forced vibration under constant conditions, the amplitude remains constant.

• Sinusoidal vibration $x = A \sin \omega t$ (fig.1)

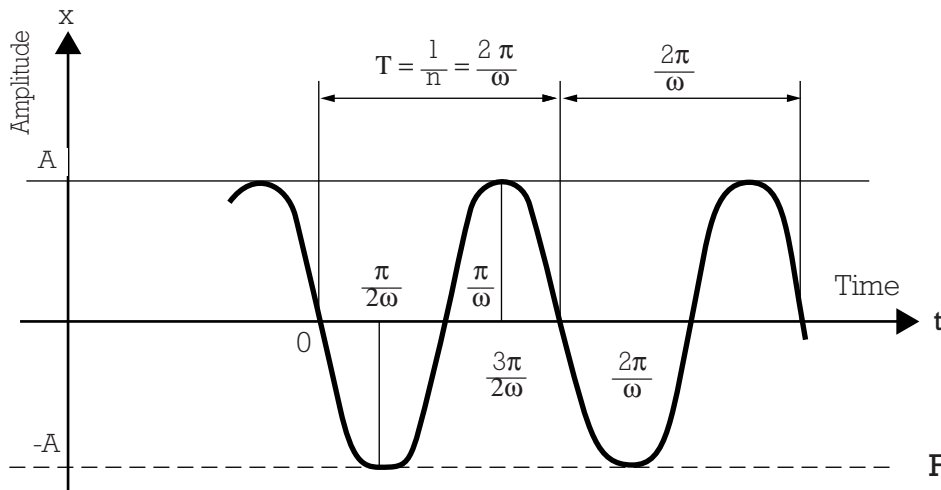

Fig. 1

- Frequency $n = \frac{1}{T} = \frac{\omega}{2\pi}$

- Amplitude A
- Maximum velocity $V = A\omega$
- Maximum acceleration $\Gamma = -A\omega^2$
- Instantaneous amplitude $x = A \sin \omega t$
- Instantaneous velocity $v = A\omega \cos \omega t$
- Instantaneous acceleration $\gamma = -A\omega^2 \sin \omega t$

High frequency vibrations (high ω) may, therefore, produce very high accelerations even at low amplitudes.

II.2.2 - Characteristics of flexible mounting systems

• Elastic properties

These are the parameters which define the freedom of a machine to move with respect to its seating. The movements are, usually, referred to an axis system (G_x, G_y, G_z).

In the example in figure 2:

- The origin of the axis system is at the equilibrium position of the machine's centre of gravity.
- The axes are parallel to the axes of symmetry of the machine.

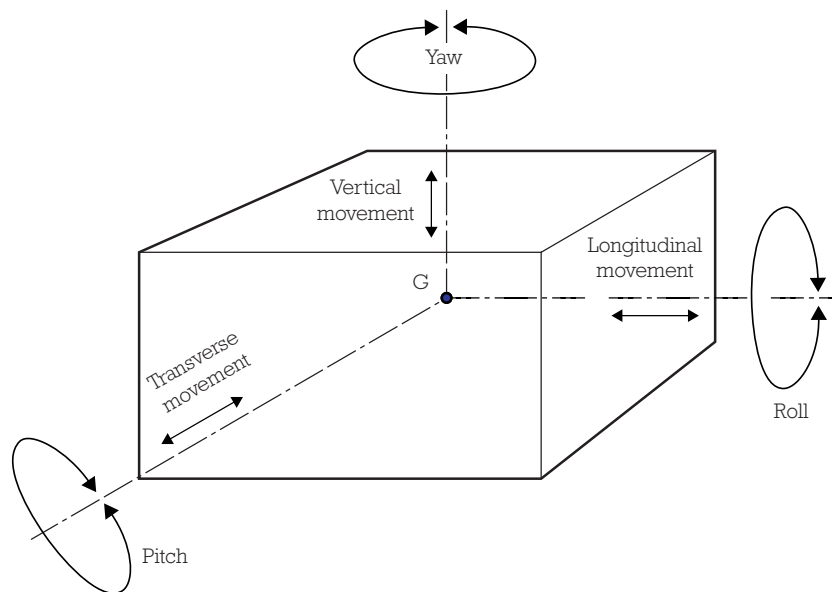

Fig. 2

As for mountings, the stiffness of a suspension is defined for displacements with only one degree of freedom relative to a fixed set of axes.

- **Linear stiffness :**

K_x along G_x = longitudinal movement

K_y along G_y = transverse movement

K_z along G_z = vertical movement

For each axis, the linear stiffness is the sum of the linear stiffness of all the mountings.

$$K_x = \Sigma k_x$$

$$K_y = \Sigma k_y$$

$$K_z = \Sigma k_z$$

- **Torsional stiffness :**

C_x about G_x = roll

C_y about G_y = pitch

C_z about G_z = yaw

The torsional stiffness of the suspension depends on :

- The individual stiffness of the mountings,
- The position and orientation of the mountings with respect to the centre of gravity G of the machine.

• **Damping properties**

Elastomers exhibit viscous damping, the braking force applied to an elastic suspension is $R \times V$, where :

R is the resistance,

V is the relative velocity of the suspended machine at time t.

If, starting with an undamped suspension, the damping is progressively increased (with all other factors remaining constant) the amplitude of the free oscillations, starting from a given initial offset, die away more and more quickly.

The value of damping for which the return to the equilibrium position is asymptotic (without oscillation) is called the “critical damping” and is denoted by a resistance R_c .

The damping factor ϵ is defined for a resistance R :

$$\epsilon = \frac{R}{R_c} \quad (\epsilon = 1 \text{ for critical damping})$$

When suspension is subjected to forced vibrations at a frequency ω , it has been shown that, for natural elastomers, the product $\epsilon \omega$ remains reasonably constant. This is equally true at the resonant frequency (see below).

$$\epsilon \omega = \epsilon_0 \omega_0 \text{ constant } (\omega_0 : \text{is the resonant frequency}).$$

$$\epsilon_0 \text{ being the damping factor at the resonance frequency.}$$

It can be shown that ϵ_0 is an intrinsic property of the elastomer used.

ϵ_0 = intrinsic damping factor.

ϵ_0 of a suspension = ϵ_0 of each mounting (if all mountings use the same elastomer).

• **Electrical characteristics**

Elastomers have an electrical resistance which varies according to their composition, hardness. As a guide, the following values have been measured for our standard elastomers.

Natural Rubber	hardness 45	10^{13}	Ohm x cm^2/cm
	hardness 60	10^6	Ohm x cm^2/cm
	hardness 75	10^4	Ohm x cm^2/cm

We have also developed special elastomers which can have a dielectric strength greater than 2,000 Volts for 1 minute.

• **Creep characteristics**

The following formula, which is derived from measurements on samples, gives an estimate of the creep for a load which compresses a Radiaflex mount by 10% of its height at a temperature of 30°C.

The creep for an actual mounting also depends equally on its shape.

Static deflection at time t = initial static deflection x (1 + Cm x f(t))
 where f(t) is the value of the creep from the graph below :

Creep f(t) in compression relative to the initial static deflection.

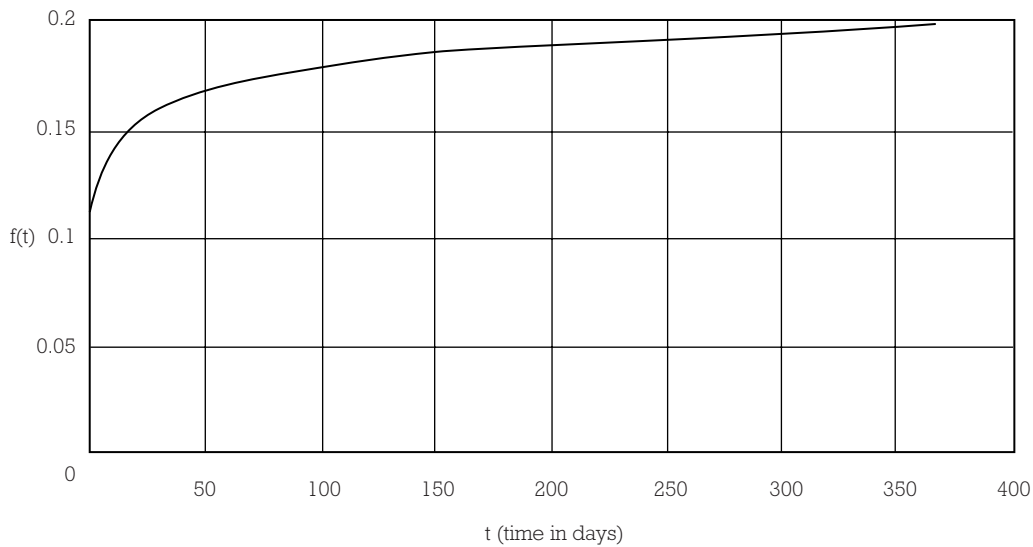

and Cm is a correction coefficient taken from the table below according to the sample material :

Material	Hardness 45	Hardness 60	Hardness 75
Standard natural rubber	1.0	1.6	1.7
Polychloroprene	1.1	1.6	1.6

Note :

These values are given as a guide only. Consult us for use under other conditions (temperature, complex profiles or other elastomers).

Mounting :

For applications where alignment is important, to overcome the problems of initial creep of the elastomer mountings, adjustment to align the axes of shafts should be made at least two days after the machine has been mounted.

III - FUNCTION OF A FLEXIBLE MOUNTING SYSTEM

III.1 - STATIC FUNCTION

An elastic suspension allows the static load to be more evenly distributed.

If a machine rests on more than three points using "rigid" mountings, it is impossible to predict the load on each mounting and the machine could be unevenly stressed.

With elastic mountings having known stiffness, it is possible to determine (by calculation, or direct measurement) the deflection in each mounting and thus deduce the loading and correct any imbalance.

An elastic suspension accomodates minor differences in the distance between mountings.

However many mountings there are, in order to avoid excessive local stresses, a rigid assembly requires very close tolerances on the distance between mountings and of the mating surfaces of the machine and its seatings.

To avoid prohibitively close manufacturing tolerances, "play" is allowed in the mountings which gives rise to the well known problems of wear and noise due to loose fixings.

Flexible mountings allow larger manufacturing tolerances without large variation in forces.

An elastic suspension can also absorb small movements due to, for example, the expansion or the deformation of chassis, bodyshells, girders, etc.

III.2 - DYNAMIC FUNCTION

This is the primary function of elastic suspensions where there is vibration or shock. The calculations presented here assume that the linear stiffness of the mountings remains constant. This is true for elastomeric mountings in normal conditions of use (mechanical vibration, normal temperature).

III.2.1 - Vibrations with only one degree of freedom

The action of a flexible mounting system is very complex. To present the principles, we will study a simple idealised case (fig. 3).

Taking the case of a machine of mass M constrained so that it can only move in a direction parallel to the vertical axis Gz .

It is attached to its seatings by a flexible mounting S with a stiffness K along the axis Gz .

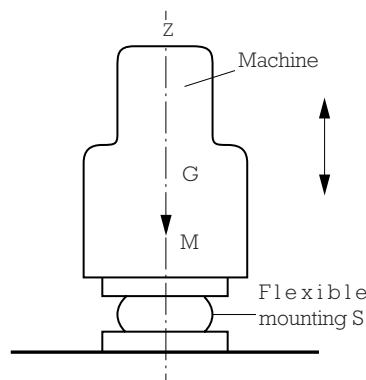

Fig. 3

• **Free oscillation (natural frequency)**

a) Undamped (entirely theoretical)

The machine, having been displaced from its position of equilibrium by a distance A , oscillates sinusoidally.

The equation of motion is: $z = A \sin \omega_0 t$

The natural pulsation is $\omega_0 = \sqrt{\frac{K}{M}}$ Proper frequency $F_p = \frac{\omega_0}{2\pi}$

The oscillation continues indefinitely with an amplitude A (as shown in Fig. 1 with ω replaced by ω_0).

b) Damped

In this case, the machine oscillates about its position of equilibrium with a damped sinusoidal motion (see Fig. 4).

The equation of motion is:

$$z = A \cdot e^{-\epsilon'_0 \omega'_0 t} \cdot \sin \omega'_0 t$$

The natural pulsation is:

$$\omega'_0 = \sqrt{\frac{K}{M} (1 - \epsilon_0'^2)} = \omega_0 \sqrt{1 - \epsilon_0'^2}$$

ϵ_0' is the damping factor at the frequency ω'_0 .

As ϵ_0' is very close to ϵ_0 , the natural frequency may, therefore, be written as:

$$\omega'_0 \approx \omega_0 \sqrt{1 - \epsilon_0^2}$$

For natural rubber, ϵ_0 is small by comparison with 1 (from 0.02 to 0.1).

ω'_0 is, therefore, very close to ω_0 .

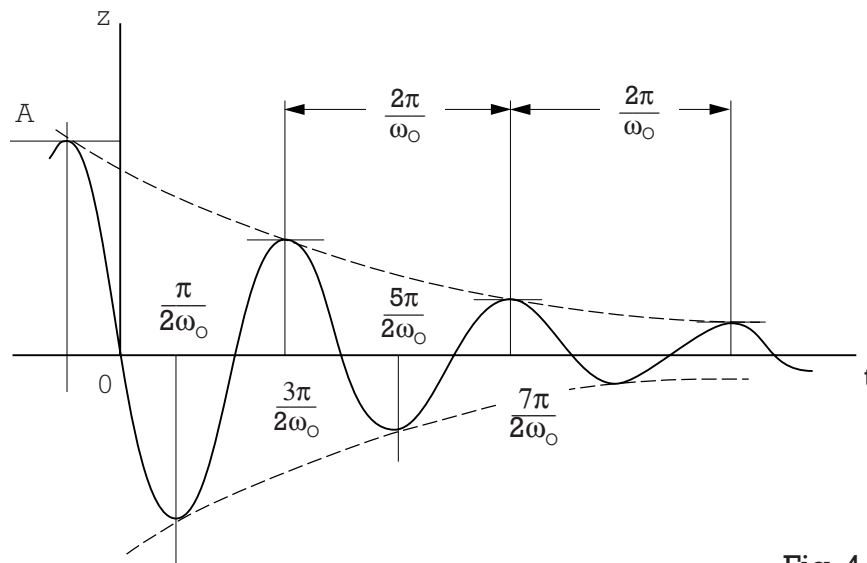

Fig. 4

• **Forced Vibration**

If the machine is now subject to forced vertical vibration induced by a sinusoidal force of frequency ω .

The inducing force is $F = F_M \sin \omega t$.

- **For a rigid suspension** : the inducing force is transmitted directly to the structure the machine is mounted on.

- **For an elastic suspension** with a natural frequency ω_0 or proper frequency $F_p = \frac{\omega_0}{2\pi}$ and damping factor ϵ_0 :

When the inducing force is applied, an oscillation is induced at the natural frequency ω_0 which dies away rapidly so that, after a short period, only the steady state forced vibration at frequency ω remains which transmits a sinusoidal force to the surrounding structure.

The force transmitted is : $F' = F'_M \sin \omega t$.

A transmission coefficient λ is defined as the ratio between the amplitude of the force transmitted F'_M to the amplitude of the inducing force F_M (or, if preferred, the force that would be transmitted if the suspension was not elastic).

For a mounting system using elastomeric mounts, this coefficient is :

$$\lambda = \frac{F'_M}{F_M} = \sqrt{\frac{1 + 4 \epsilon_0^2}{\left(1 - \frac{\omega^2}{\omega_0^2}\right)^2 + 4 \epsilon_0^2}}$$

To summarise :

	Inducing force	Transmitted force	Transmission coefficient
Rigid system	$F = F_M \sin \omega t$	$F = F_M \sin \omega t$	$\lambda = 1$
Flexible system (ω_0, ϵ_0)	$F = F_M \sin \omega t$	$F' = F'_M \sin \omega t$	$\lambda = \frac{F'_M}{F_M} = \sqrt{\frac{1 + 4 \epsilon_0^2}{\left(1 - \frac{\omega^2}{\omega_0^2}\right)^2 + 4 \epsilon_0^2}}$

The variations of the transmission, coefficient λ , as a function of $\frac{\omega}{\omega_0}$ for various values of ϵ_0 are shown in fig. 5 (page 13).

Attenuation

For rubber mountings, the term $4 \epsilon_0^2$ is much smaller than 1. The attenuation in % is $1 - \lambda$:

$$E\% = 100 \frac{\left(\frac{\omega}{\omega_0}\right)^2 - 2}{\left(\frac{\omega}{\omega_0}\right)^2 - 1} \quad \text{or} \quad 100 \left(1 - \frac{1}{\left(\frac{\omega}{\omega_0}\right)^2 - 1}\right)$$

For a given induced frequency ω the attenuation depends on the natural frequency of the suspension.

For a particular direction, the relationship between the natural frequency, the suspension's sub-tangent and the induced frequency are plotted on the chart fig. 6.

For a particular induced frequency (for example 1500 rpm) it is possible to find the sub-tangent which will provide an acceptable attenuation. In general, an attenuation greater than 50% is required. For this example, the chart indicates that an attenuation of 80% will be achieved for a natural frequency of 10 Hz (see section IV.3.1).

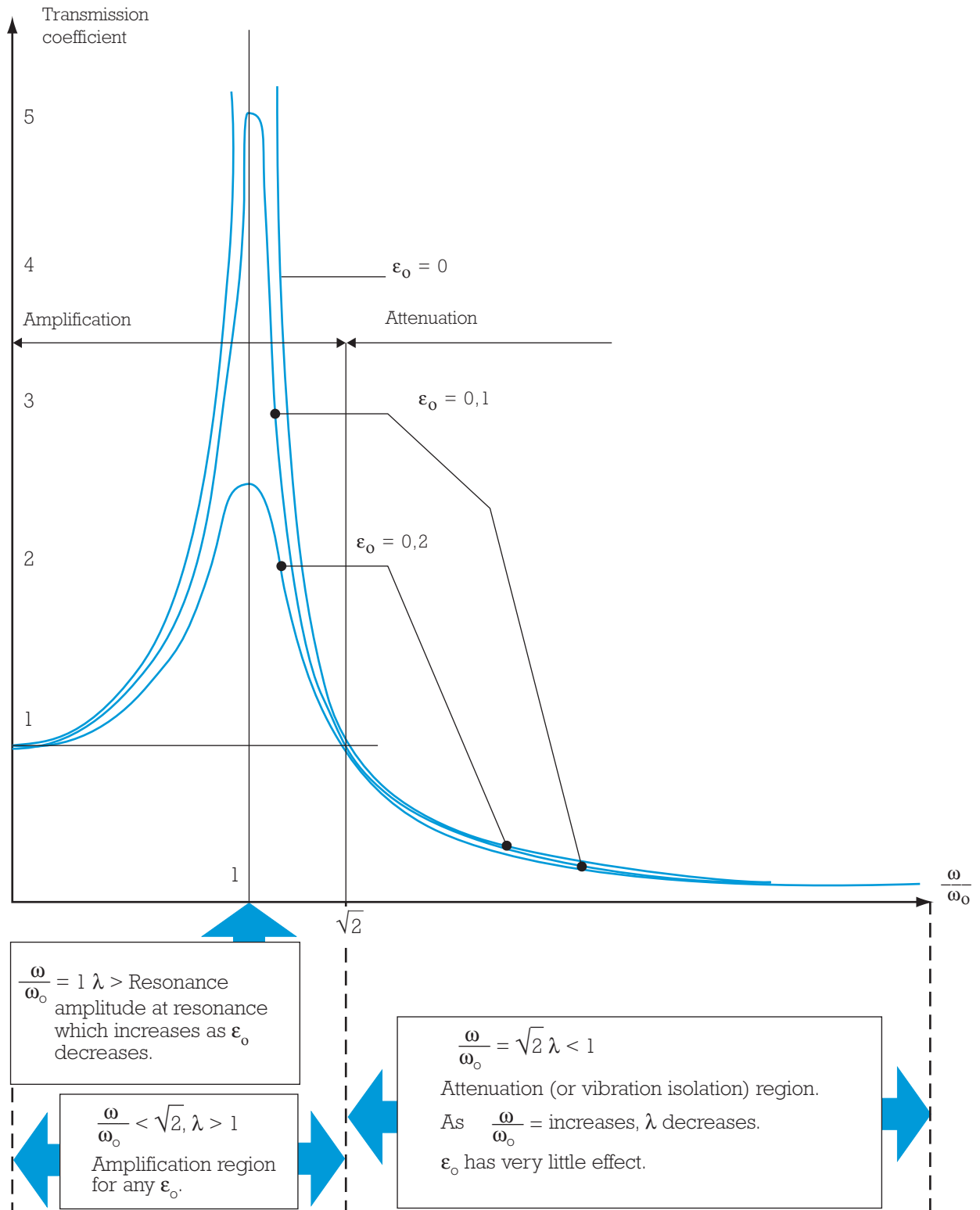

Fig. 5

An efficient mounting system use :

- a high value of $\frac{\omega}{\omega_0}$ \longrightarrow low value of ω_0 \longrightarrow low value of λ
- a moderate ε_0 \longrightarrow - limited amplification in the resonant region.
- minor effect in the attenuation region.

**Attenuation as a function of natural frequency and frequency of excitation.
(A theoretical graph for a mounting system without damping)**

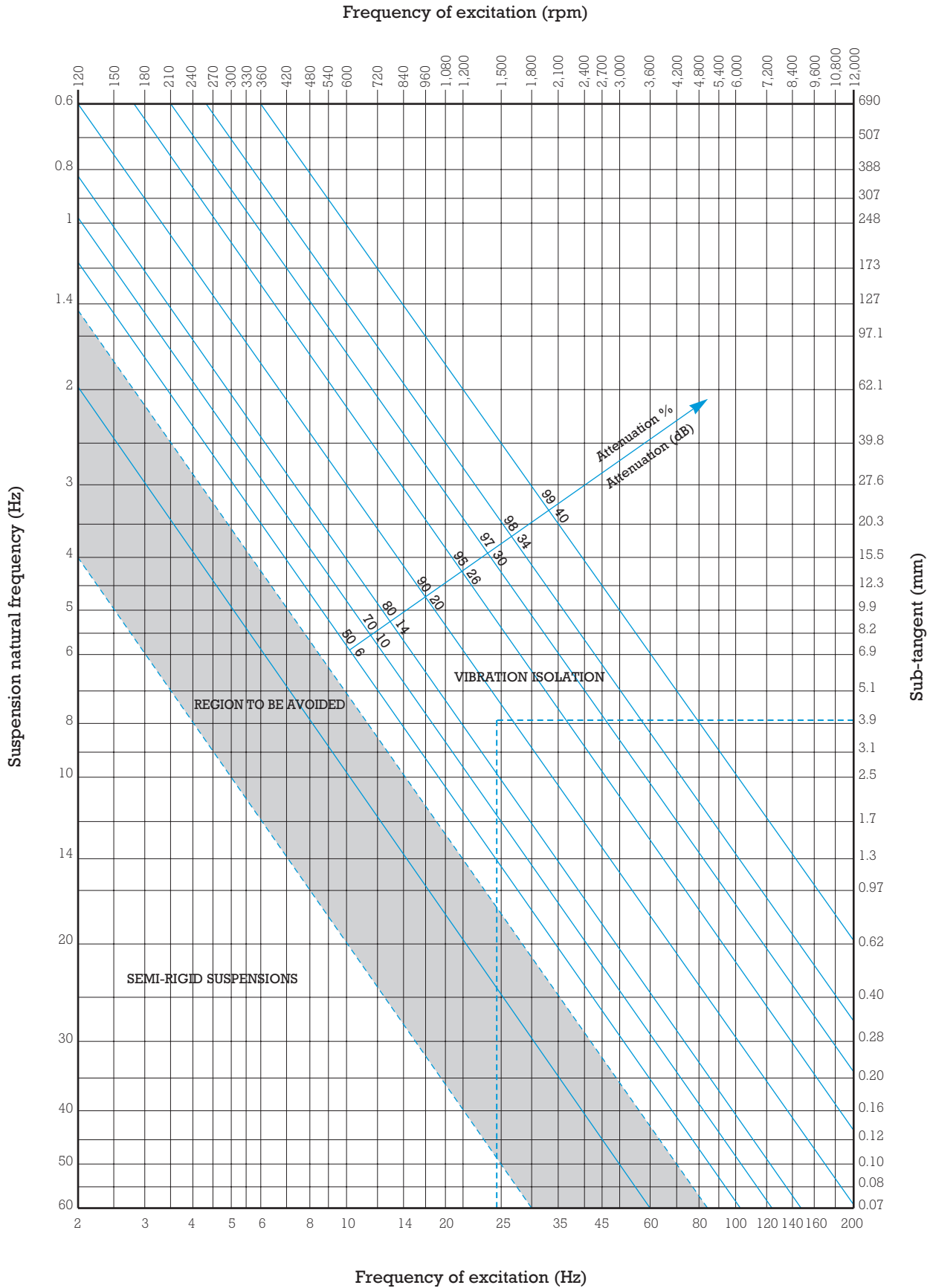

Fig. 6

• **Practical considerations**

a - Variable speed machines

In practice, there may not be a single, well defined value for ω , as machines may have a variable speed (variable ω).

In these cases, the vibration isolation should be determined for the lowest speed.

b - Passing through resonance

All machines must start and stop.

Starting from rest to reach the speed ω (in the vibration isolation region), it is necessary to pass through the resonant region.

It is necessary to ensure:

- that the passage through resonance is as quick as possible;
- that the suspension is sufficiently well damped so that the maximum force transmitted presents no risk for the machine, the suspension or the seating.

c - Elastomeric suspensions

For the elastomers currently used in flexible mounting systems, the intrinsic damping factor ϵ_0 lies between 0.02 and 0.1 (it can be as high as 0.2 with synthetics such as butyl rubber).

- In the vibration isolation region, the formula for the transmission coefficient is simplified as, for the values of ϵ_0 for natural rubber, the term $4\epsilon_0^2$ is negligible by comparison with 1.

$$\lambda = \frac{1}{\frac{\omega^2}{\omega_0^2} - 1} \text{ for } \epsilon_0 \text{ between } 0.02 \text{ and } 0.1$$

- At resonance $\lambda_r = \frac{1}{2 \epsilon_0}$

$$\lambda = \frac{1}{2 \epsilon}$$

For natural rubber, therefore, the amplification at resonance is between:

$$\frac{1}{2 \times 0.1} = 5 \quad \text{and} \quad \frac{1}{2 \times 0.02} = 25$$

a) Noise and vibration

Noise is a random vibration. It is formed by the combination of a number of uncorrelated fundamental frequencies. Noise gives rise to **sound**.

Airborne noise is usually treated separately from structure borne noise.

Sound is associated with the disturbance of a medium (solid, liquid or gaseous). This disturbance is in the form of a vibration of the molecules of the medium about their position of equilibrium.

b) Improving acoustics

An elastic suspension affects only structure borne noise.

This is a vibration of the building structure and a flexible mounting system breaks the transmission close to the source. The resilience of the attachment reduces the forces transmitted to the base and its vibrational energy.

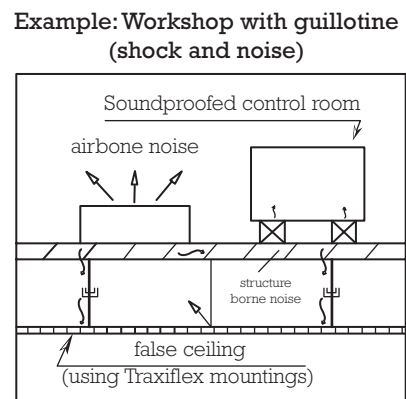
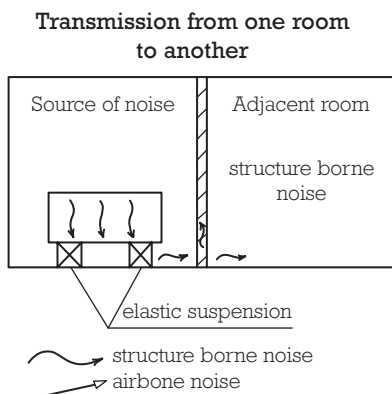

As the radiation efficiency is unchanged, the improvement in terms of radiated power (acoustic) is the same as the improvement in terms of the force transmitted. The curve giving the vibrational attenuation in % may be translated into decibels.

Attenuation in dB is $20 \log \frac{100}{100 - E}$ where E is the attenuation in %
(structure borne, not airborne noise).

The suspension of the machinery allows the **adjacent room** to be sound insulated and to be made more quiet.

The rigidity of the base supporting the suspended mass must always be taken into account. As a rule, it is considered that unless the mountings are ten times more flexible than the base the choice of suspension must be re-considered.

PAULSTRA mountings may be characterised at high frequencies.

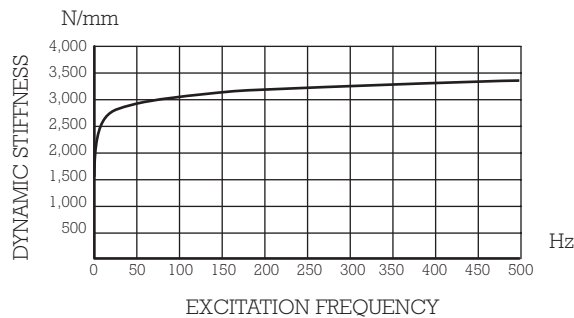

Example of measurements made on a special Radiaflex mounting.

Elastomer: polychloroprene hardness 47

Amplitude ± 0.01 mm about the position under static load

III.2.3 - Shocks

• The nature of shocks

For a given period, the equipment is subjected to a brief, impulsory excitation. It is the most severe type of excitation that it may encounter during its lifetime.

During the period that the excitation is applied, the speed of the equipment will vary: it is subject to acceleration and, therefore, to a force.

A system that reacts slowly will not be subject to the same shock as a system that reacts quickly. It is necessary to compare the length of period that the stimulus is applied, against the natural frequency of the equipment.

• Types of shocks

In practice, there are two types of problems.

- The equipment is subjected to shocks which are well defined by experiments, but are very complex and not reproducible under laboratory conditions. It is, therefore, necessary to define an equivalent shock.
- The equipment must resist shocks which are arbitrarily defined (e.g. meeting standards).

A shock is defined by an excitation which varies with time: the acceleration, the speed or the displacement of the point where the excitation is applied. In some cases, it is better to define the shock as the energy transferred to the equipment (e.g. vehicle impact).

• Protection against shocks

There are two principal cases to be considered:

a) Limitation of the force transmitted to the equipment:

This case often appears in the following form:

The equipment, moving at a known speed, meets an obstacle. The force that it can withstand without damage is limited to a known value.

A system of rubber parts, which could be the flexible mounting system of the equipment, is placed between the equipment and the obstacle.

These parts provide a constant stiffness K_z in the direction of the shock. If there is energy W to be absorbed in the absence of damping:

$$W = \frac{1}{2} K_z s^2 \quad \text{The maximum force } F_M = K_z s = \frac{2W}{s} \quad \text{The maximum force is inversely proportional to the travel.}$$

$$\text{The travel } Z = \sqrt{\frac{2W}{K_z}} \quad \text{The travel is inversely proportional to the square root of the stiffness.}$$

Note: Some systems do not have a constant stiffness, but a stiffness which increases rapidly (e.g. compression systems). It is clear that if the energy W is not absorbed before the stiffness increases, the maximum force will be much higher than predicted by this formula.

b) Limiting the acceleration of particular parts of the equipment

In this case the shock must be described in terms of its potential to destroy. The efficiency of the protection system is measured by its ability to reduce this potential.

A shock to the equipment can damage a component part if this part is induced to vibrate at an amplitude which is incompatible with its mechanical characteristics thus causing it to break.

A shock can be characterised by its action on a whole series of components.

For the same shock, each component has its own specific response, which differs from one component to the next.

The shock spectrum is the graphical representation of the ratio of amplitude of vibration (Γ) of the components to the amplitude of the shock (Γ_0) as function of the ratio of the duration of the shock τ to the natural frequency T of the elements.

This is not a representation of the amplitude as a function of time, neither of the excitation nor of the effect, but a convenient representation of the destructive power of a shock.

The representation is not reversible.

- It is not possible to recover the form of the shock from the spectrum.
- Two different shocks may well produce the same spectrum.

Take, for example, the case of shock with a semi sinusoidal acceleration.

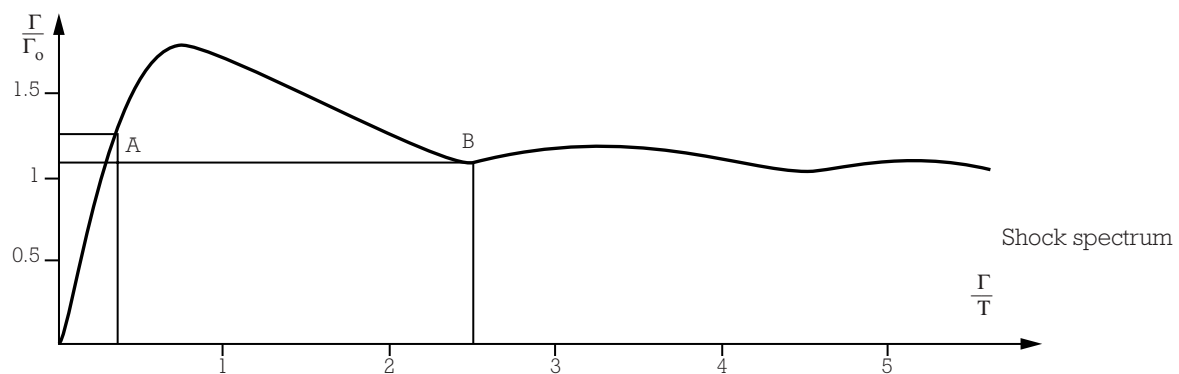

A piece of equipment must withstand a shock of $\Gamma_0 = 400 \text{ m/s}^2$ for a period $\tau = 8.75 \times 10^{-3} \text{ s}$.

	Component A of the equipment	Component B of the equipment
Natural frequency	40 Hz	286 Hz
mass	10 kg	1 kg
$\frac{\tau}{T}$	$8.75 \cdot 10^{-3} \times 40 = 0.35$	$8.75 \cdot 10^{-3} \times 286 = 2.5$
$\frac{\Gamma}{\Gamma_0}$	1.25	1.1
Load on mounting points	$400 \times 1.25 \times 10 = 5000 \text{ N}$	$400 \times 1.1 \times 1 = 440 \text{ N}$

Study of the spectrum shows that the performance of a mounting system is acceptable when it is possible to obtain a natural frequency T such as :

$$\frac{\tau}{T} < \text{in which case the ratio } \frac{\Gamma}{\Gamma_0} \text{ is less than 1 and the component is protected.}$$

If it is not possible, it is better to set up the flexible mounting system to avoid the region of significant amplification for :

$$\frac{\tau}{T} \text{ between } 0.25 \text{ and } 2.5$$

This simple case shows the role of a flexible mounting system and the importance of knowing the details (shock spectrum, amplitude as a function of time) and, above all, the duration of the shock.

• The role of damping

Damping can be useful in reducing rebounds and the amplitude of successive cycles of oscillation. It is, however, important not to use just any type of damping as some can give rise to unfortunate reactions. Elastomers provide a compromise which allow the provision a high level of protection.

• Important note

Two points must always be borne in mind when designing equipment :

- Firstly, that a high level of protection requires great flexibility which requires considerable clearance between the equipment and its surrounding.
- Secondly, that the equipment will oscillate and room must be allowed for the rebound in case of shock. Travel limiters must be positioned so that they do not impede the operation of the flexible mounting system during the shocks allowed for in the design.

A flexible mounting system using rubber protects against shock by reducing the travel and maximum force. It is necessary to allow enough clearance for the rebound.

III.2.4 - General case

Theoretical study above is based on a very simple case :

movement with only one degree of freedom (vertical) with only one excitation (also vertical) aligned with both the centre of gravity of the suspended machine and the centre of elasticity of the mounting system.

In general, things are not so simple. The machine can move in any of the degrees of freedom (rotation or linear movement). In theory, there are as many **natural frequencies** as there are degrees of freedom.

These natural frequencies are not independent but are **"coupled"**. If one of these is excited in one degree of freedom, it can, as a result of the **coupling**, give rise to vibrations at the same frequency in other degrees of freedom.

To analyse the whole behaviour, the **stiffness** in all directions needs to be taken into account and not just the mass of the suspended body but also the **moments of inertia** so that rotational behaviour can be evaluated.

In addition there may be not one but several forced vibrations, with variable frequencies applied to several different points, in various directions or about various axes.

Even general cases can be very complex however symmetrical structures and mounting arrangements allow the use of the single degree of freedom analysis shown above. In other cases only an in-depth study allows an effective solution to be found. Our Technical Services are there to help you to define it.

III.3 - VARIOUS TYPES OF FLEXIBLE MOUNTING SYSTEMS

III.3.1 - Active isolation system

This is a flexible mounting system designed to prevent a machine from transmitting its vibrations to its seating or foundation.

This is the theoretical problem (with one degree of freedom which was treated, by attenuating the vibration, in the preceding pages.

The vibration isolation does not stop the machine from vibrating, but it reduces the transmission of these vibrations.

By comparison with a rigid suspension (which transmits the vibrations) the amplitude of the machine's vibrations may be greater. The machine is, to an extent, freed from its fixed seating. This is the case for the automobile "floating engine" which, mounted on a flexible mounting system, no longer transmits its vibrations to the bodywork and the passengers due to increased mobility under the bonnet (hood).

If excessive movement cannot be tolerated, the only way to reduce it, without reducing the efficiency of the flexible mounting system, is to increase the suspended mass (ballasting).

For a given excitation, the amplitude is inversely proportional to the mass.

This is necessary for certain machines which produce particular severe vibration : slow single cylinder compressors, centrifuges, power hammers etc.

These machines, are therefore, fixed rigidly to a chassis or heavy slabs and the whole assembly is suspended.

Increasing the suspended mass allows good vibration isolation with limited vibration of the suspended assembly.

It is worthwhile suspending complete assemblies rather than individual machines : generating sets, motor/compressor units, motor/pump units.

III.3.2 - Passive isolation system

This is a flexible mounting system designed to protect a non-vibrating machine from the vibrations of its surroundings.

The design of a flexible mounting system for attenuating vibration, as defined above, is still valid. With the correct flexible mounting system, the acceleration transmitted to the machine is very small and as it is not subject to any other excitation it remains almost stationary.

The vibration of the supporting structure is almost entirely absorbed by the flexible mountings.

III.3.3 - Semi-rigid mounting system

This is a suspension where there is no vibration isolation for a given frequency ω

$$\left(\frac{\omega}{\omega_0} < \sqrt{2} \right)$$

As shown above, such a mounting system should be of no interest as it leads to an amplification of the vibration, not an attenuation. In practice, it can, however, give reasonable performance in the following two cases.

• Coupling

In practice, there is not just one movement. For a mounting system, several movements are possible. In fact, as we have seen (fig. 2), a machine may have six degrees of freedom. A proper study of a mounting system will take into account the type of excitation acting on the machine and try to arrange that it does not vibrate in all directions. However, because of constraints on mounting points, the mountings may not always be put in ideal positions : if the machine is subject to an excitation in one direction, it may, therefore, move in several directions e.g. two. These two movements are said to be "coupled".

The natural frequencies in each direction are not identical. The coupling between the two movements has the effect of lowering the lower natural frequency and raising the higher. Instead of having one maximum (fig. 5), the response curve has two. It is essential the excitation does not fall on one or the other. As it may demand an impossibly high flexibility, it is not always possible to make the coupled natural frequencies sufficiently low to put the frequency of the excitation in the vibration isolation region. On the other hand, if the two natural frequencies are placed on either side of the frequency of the excitation, a modest attenuation may be obtained.

• Harmonics

A vibration of frequency ω is rarely "pure". Frequently it also includes "harmonics" ; i.e. vibrations at related frequencies 2ω , 3ω ... Even if it is not possible to provide vibrational isolation of the fundamental ω , it may be possible to attenuate the harmonics. This may be more important as the low frequencies are often inaudible and, in addition, correspond to very small mechanical accelerations whereas the higher frequencies are a source of noise which can be eliminated by an appropriate vibration isolator.

III. 3.4 - External connections

So far, it has been assumed that the machine is only connected to its surrounding by its flexible mounting system.

In practice, there will be other connections, such as :

- Pipework (inlet, exhaust, cooling).
- Electric cables, remote controls...

It is necessary to ensure, or arrange, that these external connections are sufficiently flexible with respect to the relative movements.

This precaution will avoid :

- Damage to pipework.
- Reduced vibration isolation by introducing additional rigidity.
- Direct transmission, via these connections, of the vibrations which have been suppressed elsewhere.

As the flexible mountings attenuate the transmission of the vibrations the machine is free to move, be sure to leave enough clearance in all directions to allow freedom of movement.

IV - DESIGNING A FLEXIBLE MOUNTING SYSTEM

When designing a flexible mounting system, it is essential to know, precisely the basic characteristics of the machine to be suspended.

It is extremely useful to have a drawing (even if it is schematic) which shows the position of the centre of gravity and the mounting points provided.

The drawing may also allow the evaluation of certain parameters which may be necessary and which are often unknown to either the manufacturers or the users (e.g. moments of inertia).

For passive isolation, it is necessary to obtain the maximum of information about the external vibrations which may disturb the machine.

In any case, for complex problems (oscillations in many degrees of freedom, multiple excitation), it is advisable to consult our Technical Services.

For simple problems (one degree of freedom, or two degrees of freedom with the centre of gravity close to the mounting plane) it is possible to design the suspension, as shown below, with a minimum of information about the machine and the disturbance.

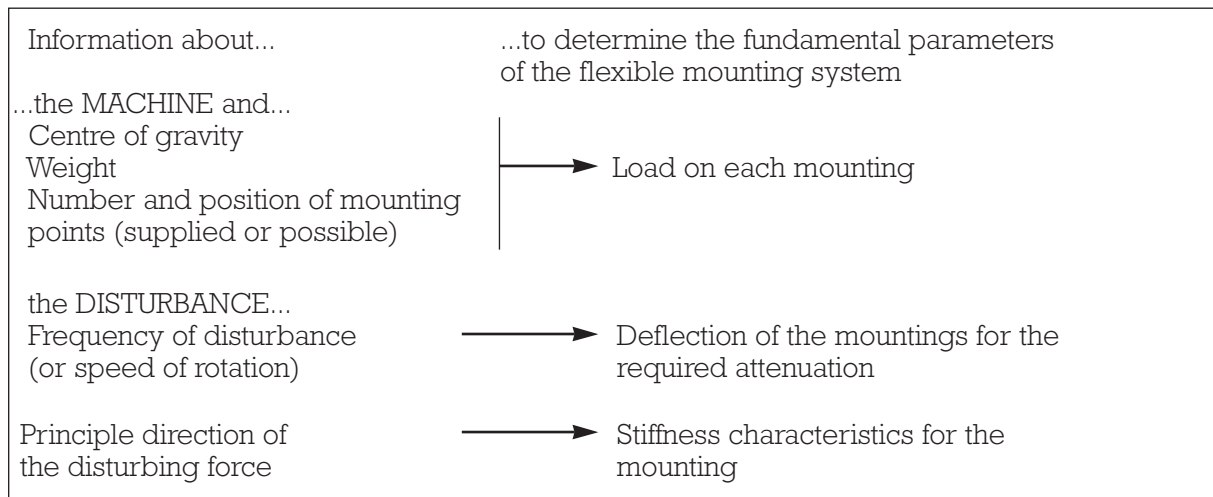

IV.1 - DETERMINING THE CENTRE OF GRAVITY

IV.1.1 - Ask the manufacturer

In most cases, the manufacturer of the machine should be able to supply the exact position of the centre of gravity as well as the weight.

Consult the manufacturer.

IV.1.2 - Graphical method for finding the centre of gravity of an assembly

This is suitable for assemblies of units for which the individual weights and centres of gravity are known.

Important notes :

- Using a graphical method, it is important to represent dimensions using a well determined scale and the weights by vertical lines whose lengths are proportional to their size (e.g. 1 cm for 10 daN).
- If the centres of gravity considered in this section are not in the same vertical plane, the procedures proposed here should be applied twice : for the front and for the side view with the outlines corresponding to each view.

- An assembly of two units

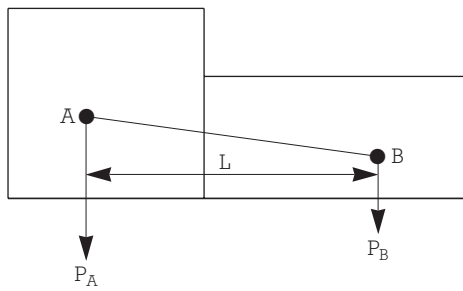

Fig. 8

Two units of weights P_A and P_B respectively with centres of gravity A and B separated by L.

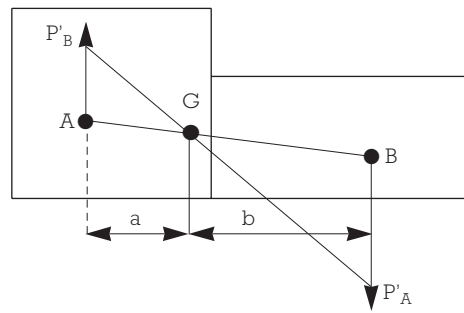
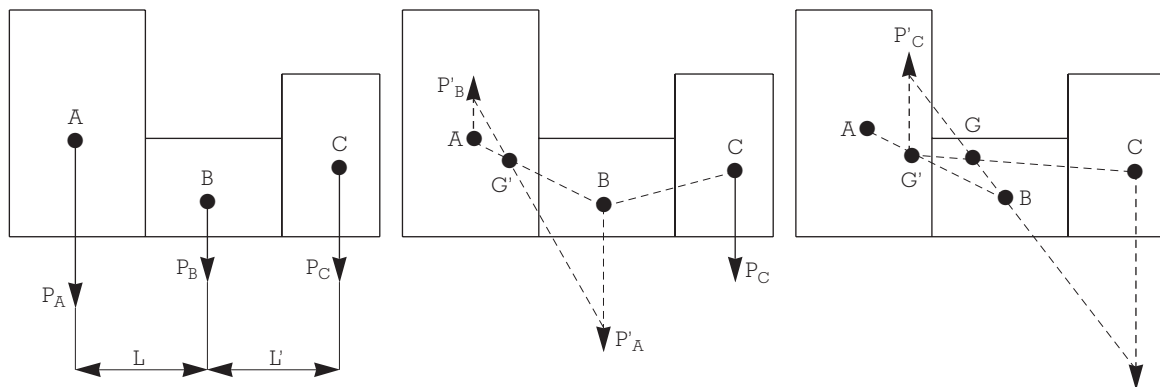

Fig. 9

Draw : $AP'_B = BP_B$ Join P'_A and P'_B
 $BP'_A = AP_A$
 The centre of gravity G lies at the intersection of the lines $P'_A P'_B$ and AB.
 Measure a and b.

- An assembly of three or more units

Proceed, stage by stage, as described above using groups of two units or sub-assemblies with centres of gravity and weight known or calculated.



IV.1.3 - Experimental determination of the centre of gravity of a unit

This method is used where the above two methods prove to be impossible or difficult (complex geometry).

- Using a roller

For a given orientation (length, width and height) the centre of gravity is in the vertical plane passing through the axis of the roller when the machine is balanced. The centre of gravity is at the intersection of the three planes thus determined.

- By “hanging”

Suspended from a cable, the centre of gravity is on the vertical dropped from the suspension point. To find the exact centre of gravity, repeat the operation twice, using a different suspension point each time.

IV.1.4 - Analytical determination of the centre of gravity of an assembly of several masses

An assembly of several masses m_1, m_2, \dots, m_n is fixed in space. It is assumed that the coordinates, within an arbitrary Cartesian set, of each mass are known.

$$m_1 \begin{cases} X_1 \\ Y_1 \\ Z_1 \end{cases} \quad m_2 \begin{cases} X_2 \\ Y_2 \\ Z_2 \end{cases} \quad m_n \begin{cases} X_n \\ Y_n \\ Z_n \end{cases}$$

The mass of the assembly $M = m_1 + m_2 + \dots + m_n$ acts at the coordinates of the centre of gravity of the whole : x, y, z

$$x = \frac{m_1 x_1 + m_2 x_2 + \dots + m_n x_n}{M}$$

$$y = \frac{m_1 y_1 + m_2 y_2 + \dots + m_n y_n}{M}$$

$$z = \frac{m_1 z_1 + m_2 z_2 + \dots + m_n z_n}{M}$$

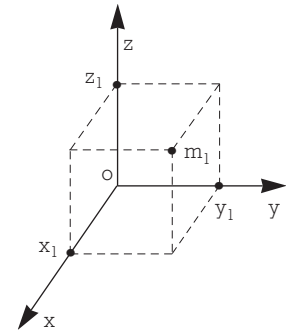

Important note : The coordinates of the centres of gravity may be negative and must be used with their sign.

IV.2 - DETERMINING THE LOAD PER MOUNTING

IV.2.1 - Number and position of the mounting points are not predetermined

In this case, the number and position of the mountings are determined in such a way that the load on each mounting is the same for all mounting points.

Taking, for example, a symmetrical machine with :

G : the centre of gravity

P : the weight of the machine

Calculate the position of 6 mounting points such that the load on all the mounting points is P_1

$$P_1 l'_1 + P_1 l'_2 = P_1 l_1$$

from which $l_1 = l'_1 + l'_2$ and the load per point = $\frac{\text{Weight}}{6}$

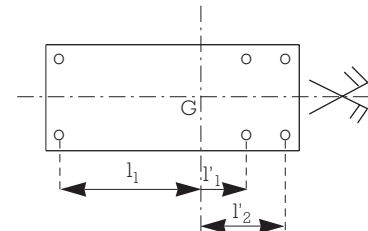

Fig. 13

IV.2.2 - Number and position of the mounting points are predetermined

In this case, it may not be possible to have the same load on each mounting.

• Four mounting points

A, B, C and D are the mounting points,

G the centre of gravity

P the total weight suspended

P_A, P_B, P_C and P_D are the loads on the mounting points A, B, C and D.

$$P_A = \frac{m_2}{b} \cdot \frac{l_2}{a} \cdot P \quad P_B = \frac{m_1}{b} \cdot \frac{l_2}{a} \cdot P$$

$$P_C = \frac{m_1}{b} \cdot \frac{l_1}{a} \cdot P \quad P_D = \frac{m_2}{b} \cdot \frac{l_1}{a} \cdot P$$

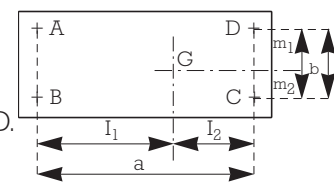

Fig. 14

If P_A, P_B, P_C and P_D are significantly different, it is, theoretically, necessary to choose four different mountings which will give the same deflection under the various loads.

• **More than four mounting points (fig. 15)**

In this case it is best if the assembly is symmetrical about a vertical plane. This is assumed to be true in the following.

To the left of G, there are 2n identical mountings.

To the right of G, there are 2p identical mountings which are, possibly, different from the 2n mountings to the left.

The problem is to set the difference between the left hand and right hand mountings so that the deflection under load of the 2n + 2p mountings are all the same.

Under these conditions, all the mountings to the left of G will be supporting the same load Q and all those to the right will be supporting the same load R.

This will give :

$$Q (l_1 + l_2 + \dots + l_n) = (\lambda_1 + \lambda_2 + \dots + \lambda_p) P$$

$$2 n Q + 2 p R = P$$

From which the mountings charge is :

$$Q = \frac{\lambda_1 + \lambda_2 + \lambda_p}{2 n (\lambda_1 + \lambda_2 + \dots + \lambda_p) + 2 p (l_1 + l_2 + \dots + l_n)} \cdot P$$

$$R = \frac{l_1 + l_2 + l_n}{2 n (\lambda_1 + \lambda_2 + \dots + \lambda_p) + 2 p (l_1 + l_2 + \dots + l_n)} \cdot P$$

If Q and R are not too different, the same size mountings may be used but with different hardness elastomers.

Example (fig.16)

Taking a symmetrical machine with an offset centre of gravity G and 6 mounting points

n = 2 et p = 1.

which gives :

$$Q = \frac{\lambda}{4 \lambda + 2 (l_1 + l_2)} \cdot P$$

$$R = \frac{l_1 + l_2}{4 \lambda + 2 (l_1 + l_2)} \cdot P$$

If the machine weighs 500 daN and $\lambda = 0.4 \text{ m}$; $l_1 = 0.3 \text{ m}$; $l_2 = 0.9 \text{ m}$, then $Q = 50 \text{ daN}$ and $R = 150 \text{ daN}$.

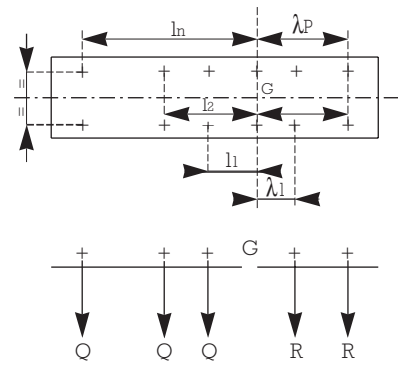

Fig. 15

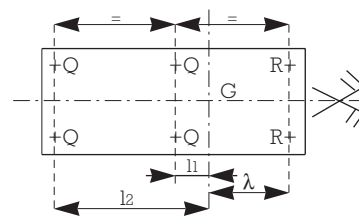

Fig. 16

IV.2.3 - Important notes

If a single size of mounting is used, but different hardness elastomers are chosen, there is a high risk that the mountings may be interchanged which may degrade the attenuation of the suspension. The machine must be mounted with great care.

There are, however, benefits from using identical mountings to build a suspension. If the predetermined mounting points of the chassis do not allow a centered suspension, the solution is to attach these to a false chassis, as rigid as possible, to which the desired number of identical flexible mountings are attached in the positions required. If this false chassis is a slab of concrete (or inertia block) the suspended mass is increased which improves the quality of the suspension.

IV.3 - DETERMINING THE DEFLECTION

IV.3.1 - Deflection and sub-tangent

Fig. 17 is a graphical representation of the derivation of the deflection and sub-tangent from the load/deflection curve.

For a given static load, the deflection corresponds to the compression of the mounting under that load, but the stiffness about the position under load is given by the sub-tangent (the projection of the tangent onto the axis). This is the elasticity which determines the natural frequency of the mounting.

$$\omega_o = C \sqrt{\frac{K}{M}} = \sqrt{\frac{1}{\text{sub-tangent}}} \quad (C = \text{constant})$$

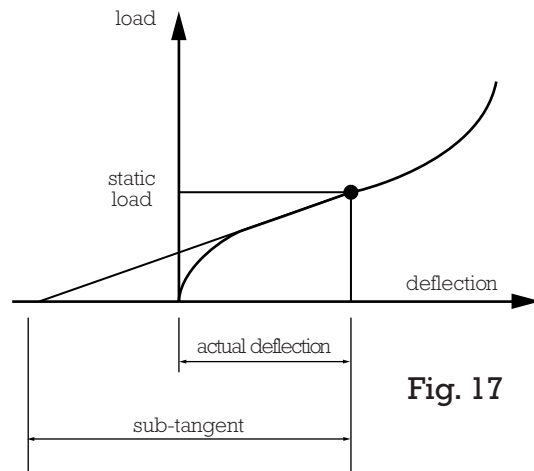

Fig. 17

For most PAULSTRA mountings, the load/deflection curve is linear in the region of static loads (fig. 18) and, as a result, the sub-tangent and the deflection are identical.

The curve in fig. 17 is typical of EVIDGOM mountings.

For these it is best to work at the point of inflection of the curve where the sub-tangent is the largest possible and so the natural frequency is as low as possible.

The deflection does not indicate the amplitude of the oscillations of the machine.

IV.3.2 - Operating regions

The region OM is the static load region. The deflection is approximately proportional to the load.

In the data sheets, the coordinates of the point M are given as the NOMINAL STATIC LOAD.

The region MP is the dynamic load region corresponding to normal, repeated shocks provided that the rate and total deflection stay within normal limits.

In the region PZ, which corresponds to exceptional, accidental shocks, the curve rises rapidly. The stiffness increases progressively which has the effect of reducing the amplitude of the movement. Note that, because of the natural damping properties of the rubber, this increase also depends on the speed of impact.

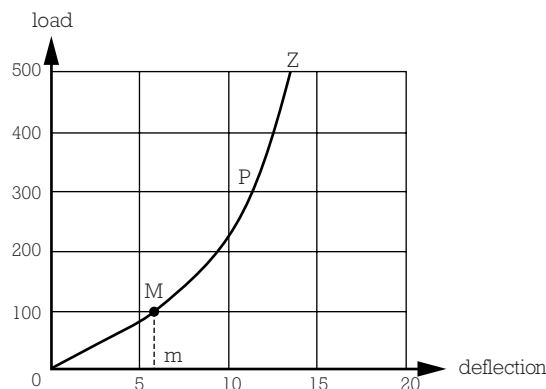

Fig. 18

IV.3.3 - Attenuation - excitation frequency

At a given excitation frequency ω , the attenuation depends on the natural frequency ω_0 and thus the sub-tangent.

With most rotating machines, the excitation frequency in cycles per minute can be taken to be the rotation speed in rpm.

As indicated on the chart (fig. 6, in § III.2.1.2) for a natural frequency in a known direction, the aim is to obtain the highest possible attenuation within the constraints of the load / deflection characteristics of the mountings.

The deflection selected must not be so high as to be detrimental to the stability of the suspension.

If the operating point is not within the vibration isolation zone, our Technical Services should be consulted.

IV.3.4 - Static stiffness - Dynamic stiffness - Natural frequency

Whereas deflection and sub-tangent are given by the static stiffness curve of the mounting, its natural frequency is linked to the dynamic stiffness. In the case of elastomeric mountings, static and dynamic stiffness can be different.

The ratio between static and dynamic stiffness depends on the input amplitude, the frequency and the type of elastomer. Under nominal load, the natural frequency is given for indication only. For a different load, the natural frequency could be found with the following formula :

$$F_p \text{ (actual load)} = F_p \text{ (nominal load)} \times \sqrt{\frac{\text{nominal load}}{\text{actual load}}}$$

This approximate is valid only if the actual load is in the linear part of the load/deflection curve (Fig. 17 & 18).

IV.4 - DESIGN EXAMPLES

PAULSTRA mountings are classified according to their stiffness characteristics

Therefore, after having determined the number and deflection of the mountings as described above, the choice of mountings depends on the direction of the excitation.

- Equi-frequency mountings : the flexibility is approximately the same vertically as horizontally.
- Mountings with high axial flexibility : high axial flexibility while supporting radial loads.
- Mountings with high radial flexibility : high radial flexibility while supporting axial loads.
- Low frequency mountings : high sub-tangent to achieve a very low natural frequency (a few Hertz).

IV.4.1 - Suspension for a fan

• Characteristics of the equipment :

- Weight : 3000 daN.
- Speed of rotation : 1200 rpm.
- Fan mounted on a 2.5 x 3 m chassis with no constraint on the position of the fixing points.
- Known centre of gravity.

Number of mountings : after trials, using successive approximation to balance the moments of inertia, 12 mountings points were selected.

Load per mounting = $3000/12 = 250$ daN.

Natural frequency of the mounts (see chart).

For an input frequency (or speed of rotation) of 1200 rpm, the maximum natural frequency is 14 Hz.

A natural frequency of 7 Hz will achieve a reasonable attenuation of about 85%.

Therefore, a mounting with a natural frequency of 7 Hz under 250 daN is required.

As it is a rotating machine with no special characteristics, isometric mountings are selected.

The selection guide gives a PAULSTRADYN mounting with a 8 mm deflection under a 260 daN load. According to the data sheet for PAULSTRADYN mountings, the PAULSTRADYN Ø 100 hardness 60 has a deflection of 7.4 mm under a load of 240 daN, which is just right.

• Suspension characteristics :

- 12 PAULSTRADYN 260. Mountings part number 533712.

- Ratio $\frac{\text{Real load}}{\text{Nominal load}} = \frac{250}{260} = 0.96$

- Attenuation $\approx 85\%^*$.
- Loaded height $\approx 32.5 \text{ mm}^*$.

* These values are given by the Paulstradyn data sheet.

IV.4.2 - Suspension of an engine/hydraulic pump unit mounted on an excavator

• Characteristics of the assembly :

- Weight : 1200 daN.
- Speed of rotation : 1500 rpm.
- Known centre of gravity.
- 6 mountings points.

Load per mounting : $1200/6 = 200$ daN.

Deflection (see chart, fig. 5).

For a frequency of 1500 rpm, a deflection of **3 mm** will achieve an attenuation of approximately 85 %.

The vibrations are predominantly vertical and the unit needs to be restrained laterally to cope with the movement of the excavator in operation. Mountings with dominant axial flexibility are selected.

The PAULSTRA mounting selection guide gives a STABIFLEX mounting with a deflection of 5 mm for a load of 210 daN. According to the STABIFLEX mounting data sheet, the mounting required is a STABIFLEX 530622 hardness 45 with a square base.

• Suspension characteristics (under 1200 daN at 1500 rpm) :

- 6 STABIFLEX mountings reference 530622 hardness 45.
- Deflection 4.7 mm.
- Theoretical attenuation 85% (16 dB).

IV.4.3 - Suspension of a sieve

• Characteristics of the equipment :

- Weight : 400 daN.
- Vibration frequency (horizontal) : 1200 cycles/mn or 20 Hz.
- Known centre of gravity.
- 6 mounting points.

Load per mounting : $400/6 = 66$ daN.

Deflection (see chart, fig. 5).

For a frequency of 20 Hz, a deflection of **6 mm** will achieve an attenuation of approximately 70%.

Mountings characteristics required :

- 1) mountings which will withstand the vertical load ;
- 2) mountings with a radial flexibility very much greater than the axial flexibility (mounting with dominant radial flexibility) ;
- 3) providing vibration isolation vertically (axially), which, taking account of requirement (2), will assure the horizontal vibration isolation.

The PAULSTRA mounting selection guide gives a RADIAFLEX cylindrical stud giving a deflection of 8 mm for a load of 70 daN.

According to the RADIAFLEX mounting data sheet, the mounting required is a stud \varnothing 30 height 30 mm with 2 mounting bolts (ref. 521312).

The radial flexibility (shear) is considerably higher than axial flexibility (compression).

• Suspension characteristics :

- 6 RADIAFLEX cylindrical mounts with 2 screws reference 521312 (theoretical vibration attenuation : 80% - 14 dB).

IV.4.4 - Suspension of a compressor unit

• Characteristics of the assembly :

- Weight : 6000 daN.
- Speed of rotation : 400 rpm.
- Known centre of gravity.
- 8 mounting points.
- Load per mounting : $6000/8 = 750$ daN.

• Deflection of mountings :

For a frequency of 400 rpm, the minimum deflection to be within the vibration isolation region is 12 mm. The PAULSTRA mounting selection guide gives a low frequency mounting which can provide sufficiently large deflections (26 mm).

According to the EVIDGOM mounting data sheet, the mounting required is an EVIDGOM mounting Ø 125, height 140 mm, reference 810784 which gives a deflection of 26 mm under a load of 800 daN.

• Suspension characteristics :

- 8 EVIDGOM mountings reference 810784, Ø 125 mm, height 140 mm.
- Deflection 26 mm.
- Attenuation 37 % (4 dB).

Note : as the low frequency mountings are tall, for some applications (sideways forces) it may be necessary to provide lateral stops.

IV.4.5 - Suspension from a ceiling (false ceiling, ventilation units, pipework)

- For light loads of 15 to 135 kg per item our TRAXIFLEX mountings may be used directly.

Example of use :

False ceiling - load per mounting 50 kg - frequency of excitation 25 Hz - mounting selected 535611 hardness 45 - deflection under load 4 mm - theoretical vibration attenuation 77 % - 13 dB.

- For heavy loads, it is necessary to use a PAULSTRADYN, STABIFLEX or EVIDGOM mounting with a safety fixing.

Example of use :

1. Suspending a ventilation unit - weight 1000 daN - frequency 25 Hz - 4 PAULSTRADYN mountings Ø 200 reference 533718 - natural frequency ≈ 7 Hz - theoretical vibration attenuation 90 % - 20 dB.
2. Suspending a special 5 tonnes machine requiring accurate radial positioning - frequency 20 Hz - 4 STABIFLEX mountings reference 530652 hardness 60 - deflection under load 8 mm - theoretical vibration attenuation 84 % - 16 dB.
3. Suspending a 20 tonnes tank subject to longitudinal expansion - frequency 15 Hz - 4 EVIDGOM mountings reference 810733 hardness 60 - deflection under load 50 mm - theoretical vibration attenuation 95 % - 26 dB.

Mounting examples :

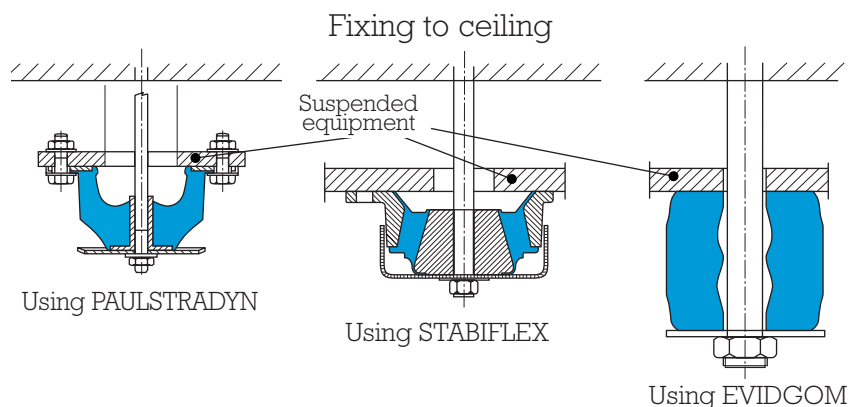



MOUNTINGS SELECTION GUIDE



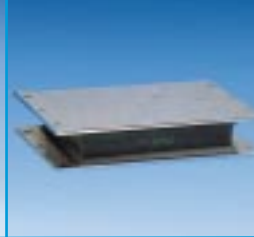

Nominal static load (daN)	HIGH RADIAL FLEXIBILITY	LOW FREQUENCY	HIGH AXIAL FLEXIBILITY	
	RADIAFLEX	PAULSTRADYN®	STABIFLEX	S.C.
				
	Deflection - mm	Deflection - mm*	Deflection - mm	Deflection - mm
4		*		0.7
8	3.5	*		0.8
10	3			0.5
12	2 - 4	*		
15	4 - 5			
20	1.5 to 5.5	*		1.5
25	7			
30	4.5 - 6	*		1.2
35	2.5 to 7			
40	0.6 to 8		3.5	0.8
45				
50	3 to 10	*		2.5
60	2.5 to 9		3	1.8 to 3.5
70	7.5 - 8	*		4
80	1.5 to 7			1.5 - 4
90	3 to 8		3.5	
100		*		3 - 3.5
120	7 to 11			2 - 3
125			4	
130		*		3.5
150	4.5 to 8.5			1.5 - 3
160	4 to 9	*	3.5 - 4	
190	10 - 11			3 - 4
200		*	5	
220				5
250	7 to 11	*	3 - 4	2 - 5
275			4.5	
300	6 to 14	*		2 - 4
350	9 to 15			3.5 - 4.5
400	5 to 17	*	3.5 - 7	4.5 - 6
450	7 to 19		8	3 - 6.5
500	17	*		
550				2.5 - 3.5 - 4.5
600	7 to 10	*		5
700	18		8	6.5
800		*		
825				6.5
900	12			5 - 8
950	7 - 8			
1000		*	8	
1100	8			3 - 5 - 9.5
1250			7.5	11
1400		*		3 - 9.5
1600				11
1800			8	8.5
2000				
2100				8.5
2300				5
2600				5
5000				
8000				
9000				
14000				

* Range of parts using the same deflection (± 6.5 mm) to provide a natural frequency at 7 Hz.

MOUNTINGS SELECTION GUIDE

LOW FREQUENCY	HIGH AXIAL FLEXIBILITY		HIGH SHEAR FLEXIBILITY	Nominal static load (daN)
EVIDGOM®	S.T.C.	TRAXIFLEX	SANDWICH	
				
Deflection - mm	Deflection - mm	Deflection - mm	Deflection - mm	
				4
				8
				10
				12
		4		20
		4		25
	0.7			30
				35
				40
	0.7	4		45
10				50
	1.2			60
		4		70
		4		80
15	1.2			90
				100
				120
		4		125
18	1.2			130
				150
				160
				190
				200
	2			220
				250
	1.2			275
				300
20	2			350
				400
	2			450
				500
24				550
	3			600
10 - 16 - 26				700
				800
				825
				900
				950
	1 - 3			1000
				1100
28				1250
				1400
				1600
				1800
35				2000
				2100
				2300
				2600
50			12	5000
50				8000
60			6	9000
60			5	14000
			6	20000
			7	30000
			5	45000



MOUNTINGS APPLICATION GUIDE

APPLICATIONS	HIGH RADIAL FLEXIBILITY	LOW FREQUENCY	HIGH AXIAL FLEXIBILITY		
	RADIAFLEX	PAULSTRADYN®	STABIFLEX	S.C.	S.T.C.®
					
FANS	■	■			
AIR CONDITIONING	■	■			
PUMPS	■	■	■		
COMPRESSORS	■	■	■		
GEARBOXES			■	■	■
GENERATING SETS	■	■	■	■	
IC ENGINES			■	■	■
PLANT CABS			■	■	■
VIBRATING TABLES/SCREENS	■	■			
HOPPERS	■	■			
MACHINE TOOLS			■		
PRESSES, GUILLOTINES			■		
GANTRIES					
CIVIL ENGINEERING					
CEILING, PIPEWORK					
LABORATORY EQUIPMENT	■	■			
ELECTRICAL ENCLOSURE	■	■			
TRANSFORMERS		■			
FRAGMENTERS		■			
SIEVES	■				

In general :
 For fixed installations : RADIAFLEX, PAULSTRADYN and BECA.
 For mobile installations : STABIFLEX, S.C., S.T.C.
 Avoid using the mount with the rubber to metal bond area in tension.
 These mounts should only be used in compression or shear.

MOUNTINGS

APPLICATION GUIDE

LOW FREQUENCY	HIGH AXIAL FLEXIBILITY		HIGH SHEAR FLEXIBILITY	LOW FREQUENCY	APPLICATIONS
EVIDGOM®	TRAXIFLEX	NIVOFIX	SANDWICH	BECA	
					
					FANS
					AIR CONDITIONING
					PUMPS
					COMPRESSORS
					GEARBOXES
					GENERATING SETS
					IC ENGINES
					PLANT CABS
					VIBRATING TABLES/SCREENS
					HOPPERS
					MACHINE TOOLS
					PRESSES, GUILLOTINES
					GANTRIES
					CIVIL ENGINEERING
					CEILINGS, PIPEWORK
					LABORATORY EQUIPMENT
					ELECTRICAL ENCLOSURE
					TRANSFORMERS
					FRAGMENTERS
					SIEVES



Recommended application



Admissible application

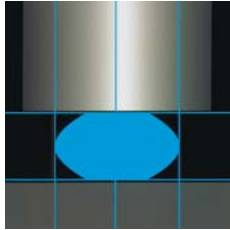

RADIAFLEX



DESCRIPTION

- Metalwork: Mild steel, plated.
- Natural rubber, bonded, cylindrically shaped.
- Welded fixings: 5 styles (single sided threaded stud, single sided threaded hole, double threaded stud, double threaded holes, combination fixing).

In Europe, we often use different screw standards than our french standard.

To better satisfy this need, Paulstra has created a new range TRadiaflex Europe.

This range is available with the 4 usual welded fixings and with a new fixing: **the threaded hole stop**.

CHARACTERISTICS

The design of the RADIAFLEX mount gives the following basic characteristics:

- Radial elasticity greater than axial elasticity.
- The rubber works in:
 - compression (axial).
 - shear (radial).
 - compression/shear according to the fixing method.

Advantages:

- Simple to fix.
- Simple and economical.
- Extensive range:
 - 13 stud diameters.
 - Several heights for each diameter.
 - 5 methods of fixing.

Recommendations:

- Operation in shear is very useful for vibration isolation provided that the radial forces are not too great.

DIMENSIONS AND COMPRESSIVE LOADS

SINGLE STUD FIXING

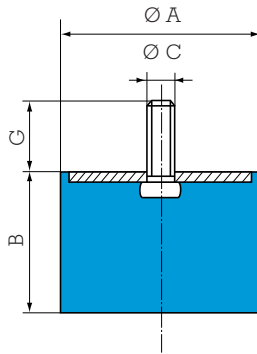

DOUBLE STUDS FIXING

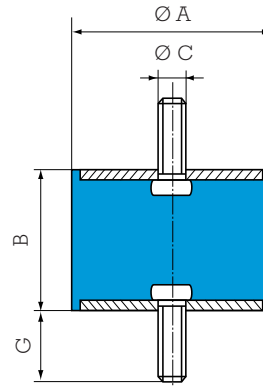

New RADIAFLEX references

Ø A mm	B mm	Ø C	G mm	Compression		Ref.
				Max. load daN	Deflection mm	
12.5	10	M5	10	12	2	511110
	13.5			11	2.5	511128
	15			10	3	511115
	20			8	3.5	511125
16	10	M4	10	20	2	511150
	15			3	511151	
	15	M5	12	20	2	511292
	20			3	511294	
20	15	4	511296			
25	15	5	511298			
20	8.5	M6	16.5	40	1.5	511200
	15			35	4	511215
	20			30	5	511220
	25			30	5.5	511225
	30			25	7	511230
25.5	10	M6	18	80	2	511158
	15			60	3.5	511155
	20			50	5	511159
	30			50	8	511160
	10	M8	20	80	2	511265
	15			60	3.5	511270
19	55	4.5	511251			
22	50	5.5	511275			
25	50	6	511280			
30	50	8	511285			
40	50	10	511290			
30	15	M8	25	90	3.5	511308
	22			80	6	511310
	30			70	8	511312
	30			70	8	511312
	40			60	9	511314
40	30	M8	20	120	7	511157
	40			120	10	511161
	20	M10	25	160	5	511450
	25			150	6	511401
	35			120	8	511452
	40			120	10	511454
45	120	11	511456			
50	25	M10	25	300	6	511525
	35			250	9	511535
	45			190	11	511545
60	22	M10	25	350	3	513601
	25			400	6	511625
	36			300	9	511635
	45			250	11	511645
70	35	M10	25	450	9	511735
	50			350	12	511750
	70			300	14	511770
80	25	M14	45	1100	6	513801
	30			950	8	511830
	40			600	10	511840
	70			500	17	511870
	70			500	17	511870
	80			450	19	511880

Threaded hole fixing on request (except Ø 12.5).
See current price list for availability of items.

See Vibrachoc elastomer range : Threaded studs

Ø A mm	B mm	Ø C	G mm	Compression		Shear*		Ref.
				Max. load daN	Deflect mm	Max. load daN	Deflect mm	
10	8	M3	6	10	1.6	1.25	0.9	**
12	8	M3	6	12	1.2	1.5	0.75	**
12.5	10	M5	10	12	2	1.5	1.5	521293
	15			3	2.5	2	521128	
	20			8	3.5	2.5	4	521295
16	10	M4	10	20	1.5	2.5	1.5	521650
	15			3	2.5	2	521651	
	10	M5	12	20	1.5	2.5	1.5	521292
	15			20	3	2.5	2	521294
20	15			4	2.5	4	521296	
25	15	5	5	5	5	521298		
20	8.5	M6	16.5	40	0.6	5	1	521178
	15			35	3	5	2.5	521249
	20			30	4.5	5	3.5	521297
	25			30	5.5	4.5	4.5	521299
	30			25	7	4.5	4.5	521319
25.5	10	M6	18	80	1.5	8	1.5	521655
	15			60	2.5	8	2.5	521656
	20			50	2	8	4	521652
	30			50	7.5	8	6	521653
	10	M8	20	80	1.5	8	1.5	521340
	15			60	2.5	8	2.5	521341
22	50	4	8	4	521251			
25	50	5.5	8	4.5	521342			
30	50	7.5	8	6	521343			
40	50	10	6.5	6	521344			
30	15	M8	25	90	3	11	2.5	521308
	22			80	5	11	4	521310
	30			70	8	11	6	521312
	30			70	8	11	6	521312
	40			60	9	11	7.5	521314
40	30	M8	20	150	6	20	5.5	521181
	40			120	10	20	7.5	521657
	20	M10	25	160	4	20	3	521450
	28			150	6	20	5.5	521401
	35			120	8	20	6.5	521452
	40			120	10	20	7.5	521454
45	120	11	20	9	521456			
50	25	M10	25	300	6	25	4.5	521580
	35			250	8	25	7	521581
	45			190	11	25	9	521582
60	25	M10	25	400	5	30	4.5	521601
	36			300	8	30	7	521603
	45			250	11	30	9	521641
70	35	M10	25	450	8	35	6.5	521705
	50			350	11	35	11	521710
	50			350	11	35	11	521710
	70			300	14	35	15	521711
80	40	M12	28	600	9	40	7	521658
	30			45	950	7	40	5
	30	35	950	7	40	5	521840	
	40	35	600	9	40	7	521841	
	70	35	500	17	40	15	521842	
	80	35	450	19	40	17	521843	
100	40	M16	47	1100	8	60	7	521908
	55			900	12	60	10	521909
	70			750	19	60	17	521910
	80			750	19	60	17	521910

*The shear characteristics are measured under Axial Load.
**See VIBRACHOC elastomer range : references E3RP.



COMBINATION FIXING

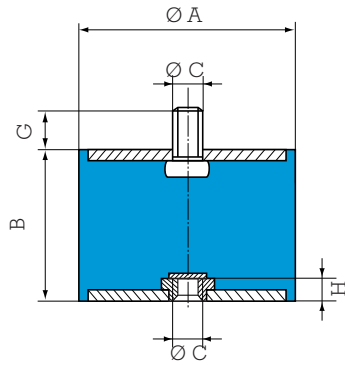

THREADED HOLE FIXING

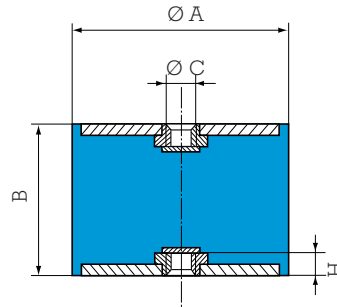

Ø A mm	B mm	Ø C mm	G mm	H mm	Compression		Shear*		Ref.
					Max. load daN	Deflect. mm	Max. load daN	Deflect. mm	
16	10	M4	10	2	20	1.5	2.5	1.5	520053 520054
	15				3	2.5	2.5		
	10	M5	12	3	20	1.5	2.5	1.5	520010 520011 520012 520013
	15				3	2.5	2		
	20				4	2.5	4		
25	5				2	5			
20	15	M6	16.5	4	35	2.5	5	2.5	520015 520016 520017 520018
	20				4.5	5	5		
	25				5.5	4.5	4.5		
	30				7	4.5	4.5		
	25				7	4.5	4.5		
25.5	15	M6	18	4	60	2.5	8	8.5	520052 520055 520057
	20				3.5	8	4		
	30				7.5	8	6		
	50				7.5	8	6		
	22	M8	20	6	50	3.5	8	4	520021 520022 520023 520024
25	5				8	4.5			
30	7.5				8	6			
40	10				6	6			
50	10				6	6			
30	15	M8	25	6	90	3	11	2.5	520025 520026 520027 520028
	22				4.5	11	4		
	30				7.5	11	6		
	40				9	11	7.5		
	60				9	11	7.5		
40	30	M8	20	6	150	4.5	20	5.5	520056 520058
	40				10	20	7.5		
	20	M10	25	8	160	4	20	3	520029 520030 520031 520032 520033
	28				5	20	5.5		
	35				7.5	20	6.5		
40	10				20	7.5			
45	11	20	9						
50	35	M10	25	8	250	8	25	7	520035 520036
	45				11	25	9		
60	36	M10	25	8	300	8	30	7	520038 520039
	45				10	30	9		
70	35	M10	25	9	450	7.5	35	6.5	520040 520041 520042
	50				10	35	11		
	70				14	35	15		
80	40	M12	28	10	600	8	40	7	520059
	40	M14	35	12	600	8	40	7	520044 520045 520046
	70				17	40	15		
	80				19	40	17		
100	40	M16	47	14	1100	8	60	7	520100 520101 520102 520103
	55				12	60	10		
	80				12	60	17		
	100				23	60	20		
	60				10	30	7		
	70				14	35	15		

Ø 16 mounts with threaded holes are fitted with RAPID nuts. Maximum torque 1.8 m.N.

Ø A mm	B mm	Ø C mm	H mm	Compression		Shear*		Ref.
				Max. load daN	Deflect. mm	Max. load daN	Deflect. mm	
16	10	M4	2.5	20	1.5	2.5	1.5	520550 520551
	15			3	2.5	2		
	10	M5	3	20	1.5	2.5	1.5	520500 520501 520502 520503
	15			3	2.5	2		
	20			4	2.5	4		
25	5			2	5			
20	15	M6	4	35	2.5	5	2.5	520505 520506 520507 520508
	20			4.5	5	3.5		
	25			5.5	4.5	4.5		
	30			7	4.5	4.5		
	25			7	4.5	4.5		
25.5	20	M6	4	50	3	8	4	520554 520555
	30			7.5	8	6		
	22	M8	6	50	3	8	4	520511 520512 520513 520514
	25			4.5	8	4.5		
	30			7.5	8	6		
40	10			6	6			
30	22	M8	6	80	4	11	4	520516 520517 520518
	30			7.5	11	6		
	40			9	11	7.5		
40	30	M8	6	150	4.5	20	5.5	520552 520553
	40			10	20	7.5		
	28	M10	8	150	4.5	20	5.5	520520 520521 520522 520523
	35			7	20	6.5		
45	11			20	9			
50	35	M10	8	250	7	25	7	520525 520526
	45			10	25	9		
60	36	M10	8	300	7	30	7	520528 520529
	45			9	30	9		
70	35	M10	9	450	7	35	6.5	520530 520531 520532
	50			9	35	11		
	70			14	35	15		
80	40	M12	10	600	7	40	7.5	520556
	40	M14	12	600	7	40	7	520534 520535 520536
	70			17	40	15		
	80			19	40	17		
100	40	M16	14	1110	8	60	7	520541 520542 520545 520546 520543 520547
	55			12	60	10		
	60			8	180	10		
	75			10	140	12		
	80			19	60	17		
	100			23	60	20		

See current price list for availability of items. 1 kg = 1 daN
* Shear characteristics are measured under axial load.

ONE THREADED HOLE

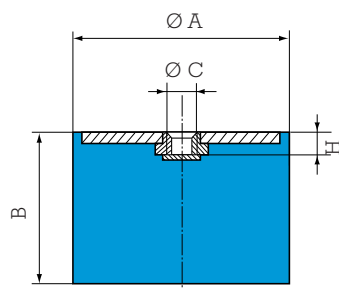

Ø A mm	B mm	Ø C mm	H mm	Compression		Ref.
				Max load daN	Deflect. mm	
16	10	M4	2.5	20	2	511152 511153
				20	3	
20	15	M6	4	35	4	511154
25.5	15	M6	4	60	3.5	511164 511162 511163
				55	5.5	
				50	8	
30	22	M8	6	80	6	511156



DIABOLO MOUNTS

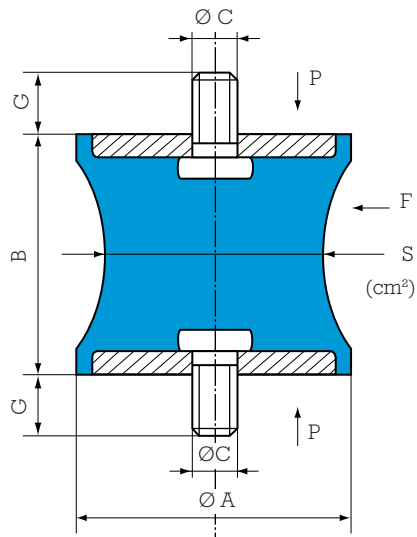

Ø A mm	B mm	Ø C	G mm	S cm ²	Compression		Shear*		Ref.
					Max Load daN	Deflection mm	Max Load daN	Deflection mm	
12.5	14	M5	10	0.3	3	1.4	0.5	1.2	521300
20	19	M6	16.5	1.6	12	2.5	3	5	521201
40	28	M10	25	3.1	30	5	2.5	4.5	521403
57	44	M8	20	5	40	5	7	5	521571
57	44	M8	20	9.5	75	5	12	6	521572
60	60	M10	25	19.5	150	8	30	10	521602
80	70	M14	35	38.5	300	9.5	55	9.5	521801
95	76	M16	45	50	400	9.5	70	8	521951

See current price list for availability of items.

1 kg ≈ 1 daN

* Shear characteristics' are measured under axial load.

Also available with Ø 30 locators on each end, 3 mm thick allow M14 threaded holes:

Ø A mm	B mm	Ø C	Depth of thread mm	S cm ²	Compression		Shear*		Ref.
					Max Load daN	Deflection mm	Max Load daN	Deflection mm	
80	60	M14	15.5	38.5	250	5	70	8	521802

ASSEMBLY

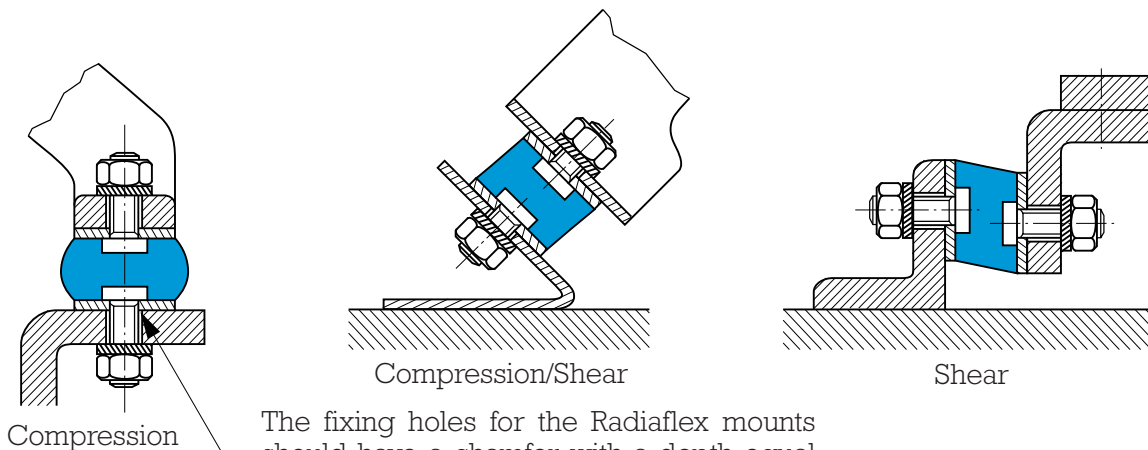

The fixing holes for the Radiaflex mounts should have a chamfer with a depth equal to the pitch of the thread.

Ex. 521401: M10 x 150 chamfer = 1.5 mm

521951: M16 x 200 chamfer = 2 mm

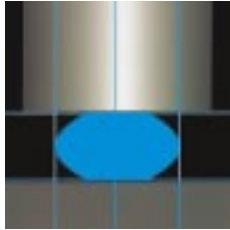

PAULSTRADYN®

New !

Natural frequency :

- axial 7 Hz
- radial 3 to 5.5 Hz



ADVANTAGES

- Better than 90% isolation at 1.500 rpm (25 Hz).
- Constant height over wide load range.
- Stabilised characteristics during Service Life.
- Simple to fit.
- 400 hours protection against salt spray*.
- Design.

* When mounted according to the recommendations given in the catalogue.



Finite element modeling

New formula SILTECH

- Low increase of stiffness with frequency
- Low creep

APPLICATIONS

Anti vibration isolation for static equipment :

- rotating machinery such as fans, air-conditioning, pumps, compressors, generator sets.
- pipework, ceilings, transformers, electrical enclosures.

DIMENSIONS

Fig. 1

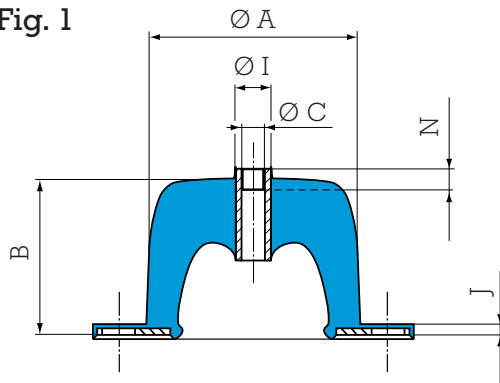
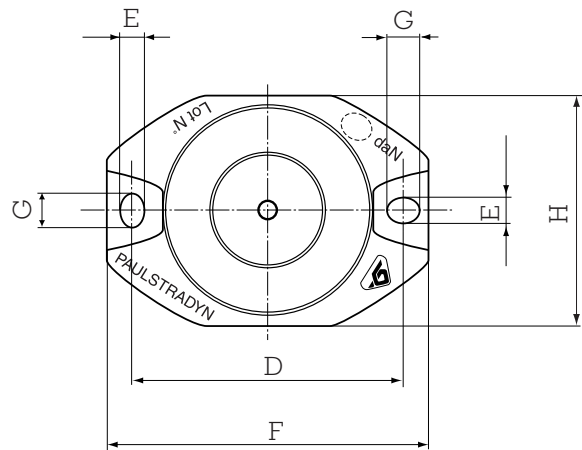
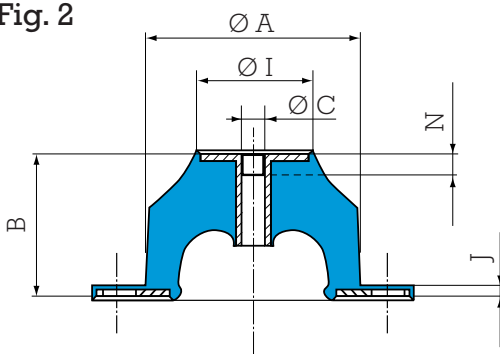

Fig. 2



Designation	Ref.	Nominal load NL (daN)	Fig.	Dimensions (mm)											
				Ø A	B*	Ø C	D	E	F	G	H	Ø I	J	N	
Paulstradyn	4 7 12	533701 533702 533703	4 7 12	1	40	40	M6	52	6.2	64	6.2	44	12	2.5	6
Paulstradyn	20 30 50	533704 533705 533706	20 30 50	2	60	40	M6	76	6.2	90	8.2	64	32	2.5	6
Paulstradyn	70 100 130	533707 533708 533709	70 100 130	2	80	40	M8	100	8.2	122	12.2	84	48	2.5	12
Paulstradyn	160 200 260	533710 533711 533712	160 200 260	2	100	40	M10	124	10.2	152	16.2	104	68	3	10
Paulstradyn	325 400 500	533713 533714 533715	325 400 500	2	150	40	M12	182	12.2	214	20.2	154	116	4.5	10
Paulstradyn	640 820 1050 1350	533716 533717 533718 533719	640 820 1050 1350	2	200	40	M16	240	14.2	280	24.2	204	159	5.5	20

* : Height, unloaded 40 mm, under load 32 mm (see Technical Characteristics).

NL : Nominal static load with mounting under axial compression.

TECHNICAL CHARACTERISTICS

The vibration attenuation and height characteristics under nominal load are **stabilised after one month under load at 20°C**.

Common characteristics

- Natural axial frequency 7 Hz, with nominal load.
- Natural radial frequency 3 to 5.5 Hz.
- Maximum displacement :
 - axial : 12 mm.
 - radial : ± 10 mm.

Vibration attenuation

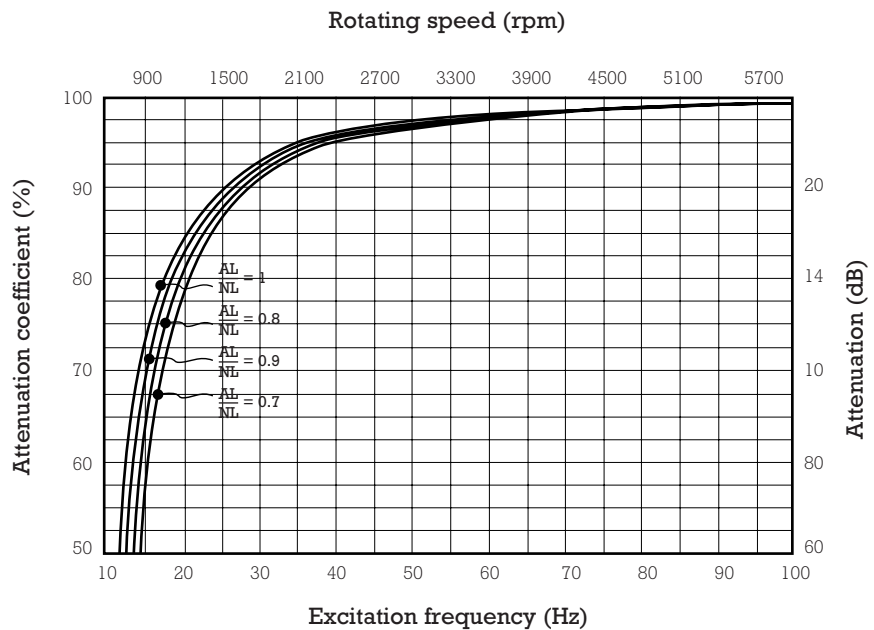

$$\frac{AL}{NL} = \text{Ratio} \frac{\text{Actual load}}{\text{Nominal load}}$$

Height under load

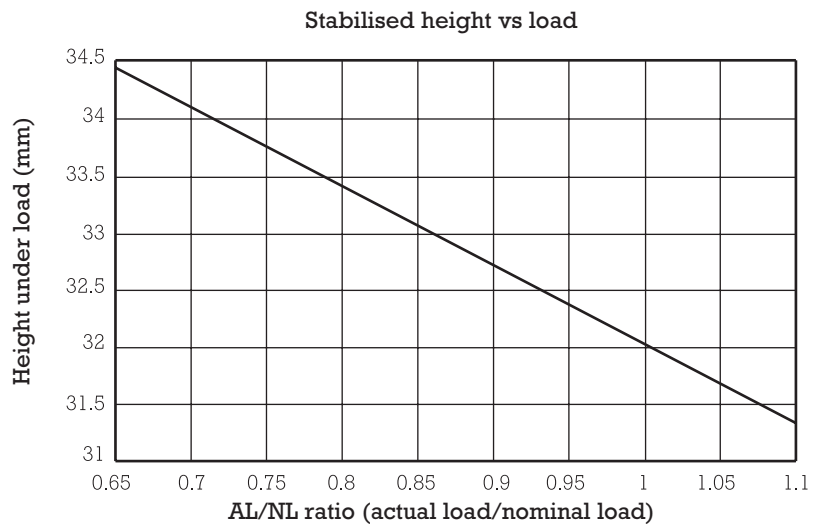

Temperature

Operating temperature : - 20°C to + 70°C.

Other characteristics*

- Good dynamic performance at high frequency.
- Withstands fatigue and shocks.
- Reduced creep.

* Detailed Technical Characteristics can be sent on request. Ask us for details.



MOUNTING

Standard mounting

- ① machine base or foot
dimensions > $\varnothing M^*$
- ② supporting structure (floor)
dimensions > base of mounting F x H* (refer page 39)
- ③ screw $\varnothing C^{**}$
- ④ screw $\varnothing K$, a washer is required between the screw head and the PAULSTRADYN*
- ⑤ screw $\varnothing K$, a washer is required between the screw head and the PAULSTRADYN*

Note : * to distribute the load and resist corrosion
** nuts and screws grade 4.6 minimum.

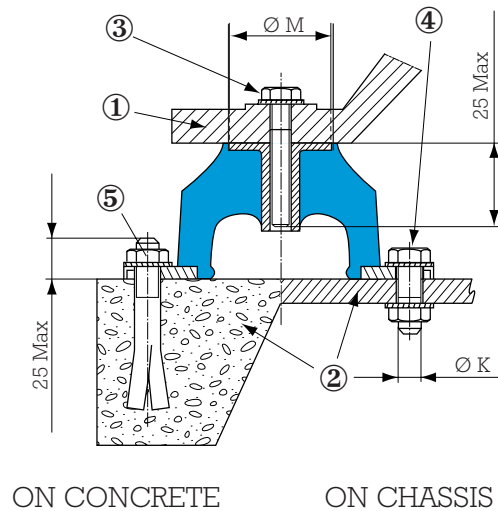

Fig. 1

Recommended torque

Diameter K (mm)	M6	M8	M10	M12
torque N.m.	2	5	12	20

Note : Do not paint the mountings after fitting.

Alternative mounting

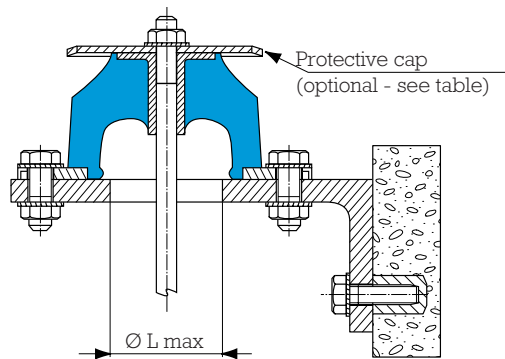
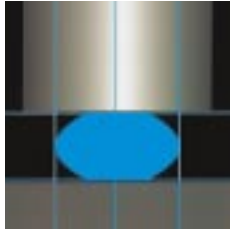

Fig. 2

Mounting and cap references

Paulstradyn references	Dimensions (mm)			Référence coupelle (en option)
	$\varnothing K$ Fig. 1	$\varnothing L$ max Fig. 2	$\varnothing M$ max Fig. 1	
533701, 533702, 533703	M5	27	14	342919
533704, 533705, 533706	M5	40	34	342356
533707, 533708, 533709	M6	46	50	342733
533710, 533711, 533712	M8	47	70	342734
533713, 533714, 533715	M10	99	118	342353
533716, 533717, 533718, 533719	M12	127	162	342354



STABIFLEX



(1) Natural frequency :
6 to 11 Hz

DESCRIPTION

The STABIFLEX mounting comprises a conical rubber section bonded between inner and outer metal parts.

- Centre axis with threaded hole.
- Square (4 holes) or diamond base (2 holes) with clearance hole.
- Bonded natural rubber, anti-slip bead.
- Cup to protect the rubber and distribute the load.

OPERATION

The design of the STABIFLEX mounting gives the following basic characteristics :

- Axial elasticity two or three times higher than radial elasticity.
- The rubber works in shear/compression.
- Progressive buffer against shocks or accidental overload.
- Anti-slip (may be placed directly on the ground).

Advantages :

- The machine may be placed with its mountings directly on the ground.
- Speed of fixing.
- Easy movement of suspended machinery.
- Rubber protected against harmful liquids.
- Extensive range : 3 hardnesses of rubber for 5 existing types, allowing the mounting to be optimised as a function of the load and forcing frequency.
- May be used with an anti-rebound washer.

Recommendations :

- In order not to affect the performances of the mounting system, all external connections must be flexible.
- STABIFLEX mountings must be fitted so that the vibration input is in the axial direction.

(1) Natural frequencies with max/min loads, see : OPERATING CHARACTERISTICS.

DIMENSIONS

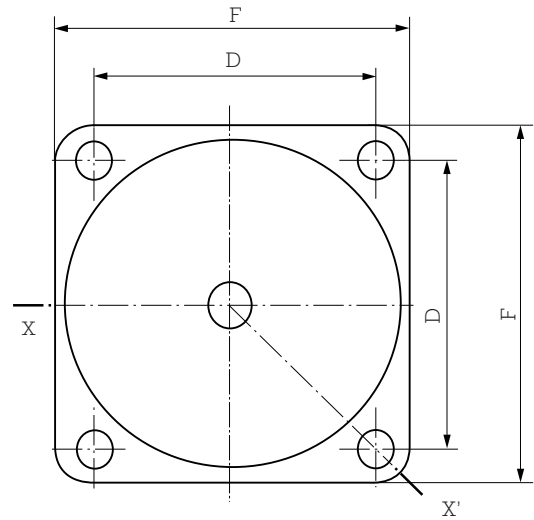
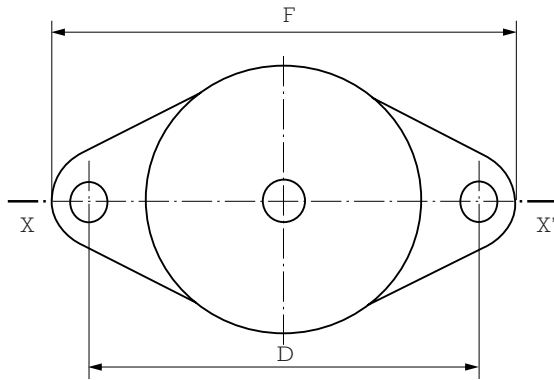
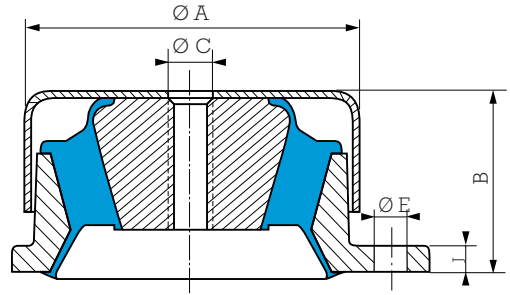
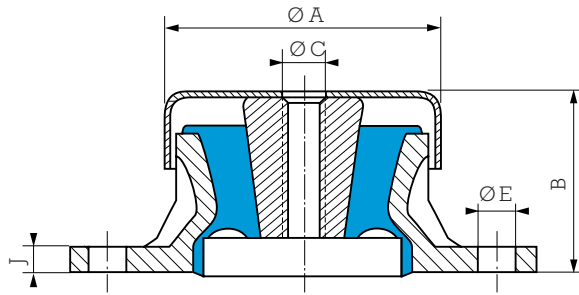

STABIFLEX - diamond base

STABIFLEX - square base

Type	Reference	Hardness	$\varnothing A$ mm	B mm	$\varnothing C$	D mm	E mm	F mm	J mm	Weight g
Diamond base	530603	45.60.75	69	41	M12	98	9	114	6	250
	530613	45.60.75	84	51	M12	115	11	137	7	450
Square base	530622	45.60.75	100	52	M12	90	11	114	7	1000
	530642	45.60	133	71	M16	114	13	144	9	2300
	530652*	45.60.75	133	71	M16	114	13	144	9	2700

* Part identified by the letter "R" (reinforced)

See current price list for availability of items.

OPERATING CHARACTERISTICS

Nominal static load daN	Deflection mm	Reference	Hardness
10 - 42	3.5	530603	45
15 - 60	3	530603	60
20 - 93	3.5	530613	45
30 - 125	4	530603	75
40 - 165	3.5	530613	60
50 - 210	5	530622	45
65 - 260	3	530613	75

Nominal static load daN	Deflection mm	Reference	Hardness
65 - 275	4.5	530622	60
95 - 380	3.5	530622	75
110 - 450	8	530642	45
175 - 700	8	530642	60
250 - 1000	8	530652	45
325 - 1300	8	530652	60
450 - 1800	8	530652	75

LOAD/DEFLECTION CURVES IN AXIAL COMPRESSION

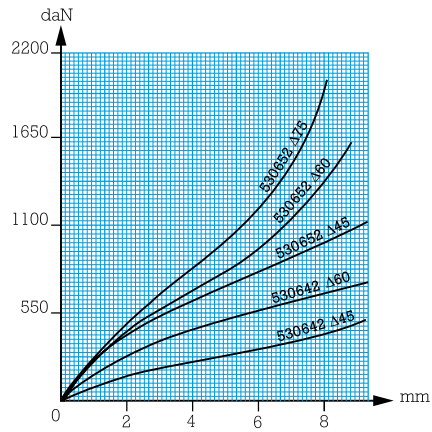
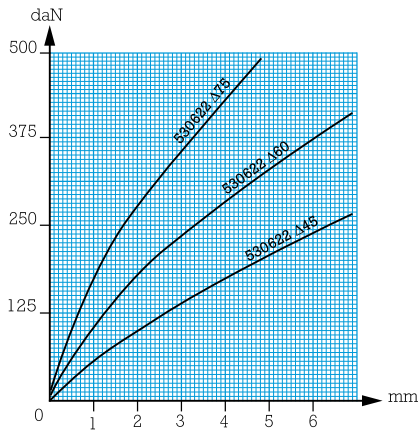
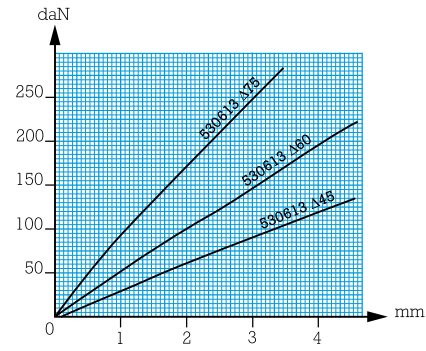
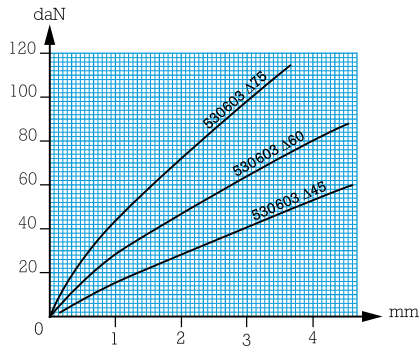

ASSEMBLY

- Standard fixing methods

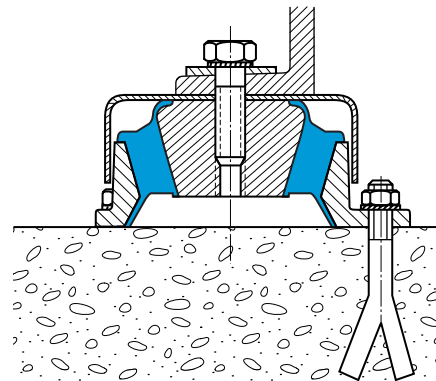
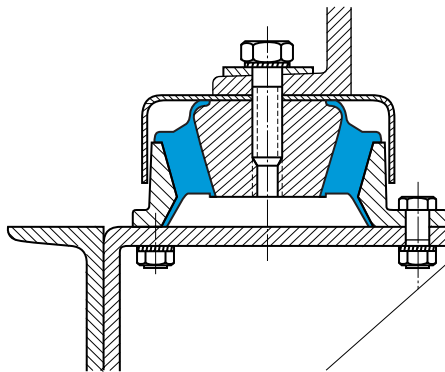

- Fixing with anti-rebound washer

- The anti-rebound washer (not supplied) is fixed to the lower side of the centre axis.
- In this case, do not forget to fit a spacer.

Spacer thickness required :

530603 h : 2 mm

530613 h : 4 mm

530622 h : 7 mm

530642 h : 14 mm

530652 h : 14 mm

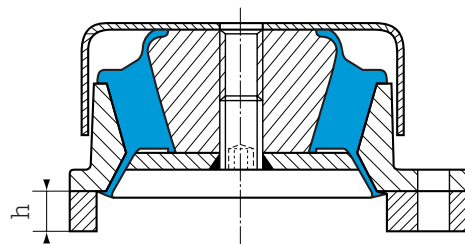

All our mountings are identified by conventional markings, either a paint spot or figures indicating the hardness : grey = hardness 45, green = hardness 60, blue = hardness 75.

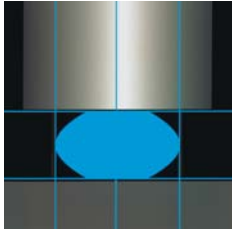

STABIFIX®

STABIFIX® AR



(1) Natural frequency:
7 to 12 Hz

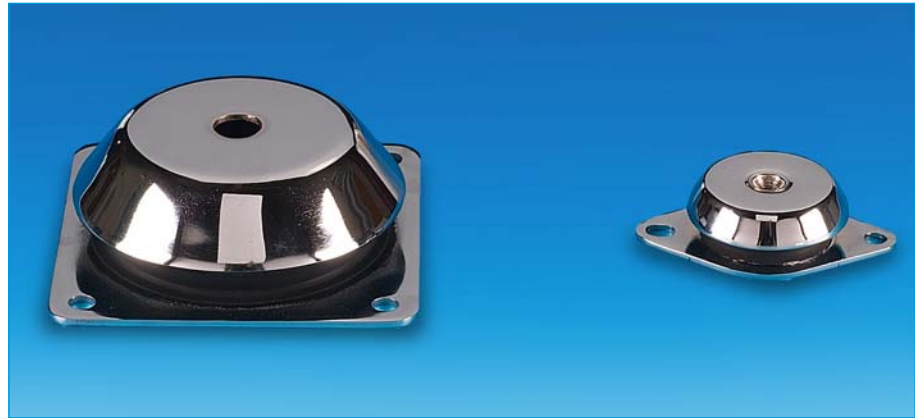

DESCRIPTION

The STABIFIX and STABIFIX AR (anti-rebound) are made of a rubber ring bonded to two metal shelves. The anti-rebound function is integrated with the STABIFIX AR version.

- Upper part with a smooth or a threaded hole (depending on version).
- Diamond base (2 holes) or square base (4 holes) for the lower fixing (2 holes).
- Natural rubber bonded.

OPERATION

The design of STABIFIX gives the following basic characteristics:

- Axial elasticity greater than radial elasticity.
- The rubber works in compression/shear.
- Progressive buffer against shocks or accidental overload.

Advantages:

- Speed of fixing.
- Easy movement of suspended machinery.
- Rubber protected against harmful fluids.
- Extensive range: 3 hardnesses of rubber allow the mounting to be optimised as a function of the load and input frequency.

Recommendations:

- In order not to affect the performances of the mounting system, all external connections must be flexible.
- STABIFIX and STABIFIX AR (anti-rebound) mountings must be fitted so that the vibration input is in the axial direction.

(1) Natural frequencies with max/min loads, see: OPERATING CHARACTERISTICS.

DIMENSIONS

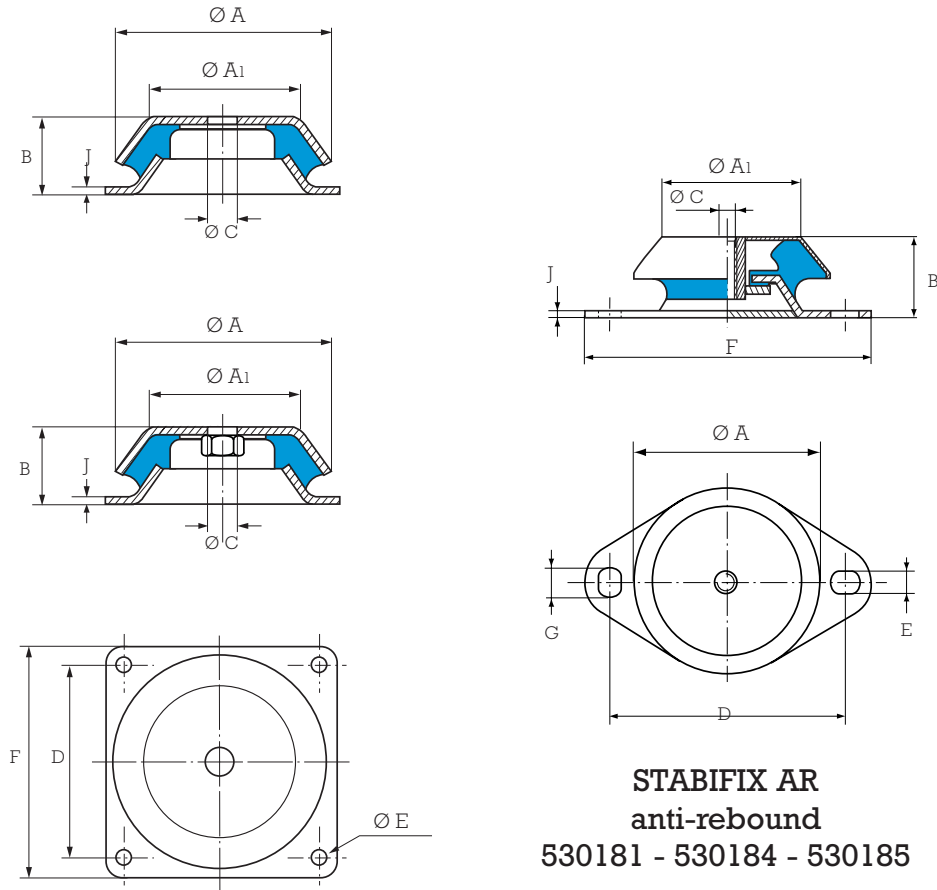

Type	Reference	Hardness	Ø A mm	Ø A1 mm	B mm	Ø C	D mm	E mm	F mm	J mm	G mm
Diamond base	530181	45.60	82	60	35	M10	110	11	135	3	15
	530184	45.60	110	87	42	M16	144	14	175	3	15
	530185	45.60	101	81	38	M16	144	14	175	3	15
Square base	530170	70	170	118	63	24.5	150	13	184	4	
	530175	70	170	118	63	M20	150	13	184	4	

See current price list for availability of items.

OPERATING CHARACTERISTICS

Nominal static load daN	Deflection mm	Reference	Hardness
30 - 75	7	530181	45
70 - 160	6.5	530181	60
110 - 220	7.5	530184	45
130 - 270	4.5	530185	45
180 - 380	7.5	530184	60
230 - 480	4	530185	60
1000 - 2000	5	530170	70
1000 - 2000	5	530175	70

1 kg ≈ 1 daN

All our mountings are identified by conventional marking indicating the hardness.

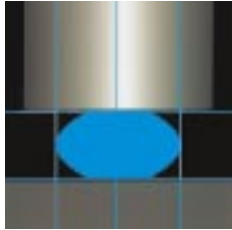

TRIAXDYN



DESCRIPTION

This anti-vibration mounting comprises two elastomers which are assembled into a casting and pre-loaded.

The mounting is designed to offer :

- a large deflection (in axial),
- different stiffness in three axis,
- built-in stops to limit movement in all directions.

Note : The mount body can be modified to offer alternative interface dimensions providing the internal interface with the elastomer is maintained.

APPLICATIONS

This mounting has been designed to isolate engines or cabs in fixed or mobile applications with a high level of isolation and shock protection. Its compact design enables fail safe suspension of loads from 150 to 280 kg.

It is suitable for :

- Engine mounting.
- Cab mounting.
- Equipment mounting.

OPERATING CHARACTERISTICS AND DIMENSIONS

- Nominal load :
 - 150 to 280 kg.

Possibility to extend, on request, the load range up to 350 kg.
- Different stiffness in three axis (for a hardness 50) :
 - Axial on Z : 500 N/mm,
 - Radial on X (in direction of voids) : 350 N/mm,
 - Radial on Y (at 90 deg. to voids) : 500 N/mm.

The geometry of the part provides low dynamic stiffness in the vertical dimension.
- Maximum deflection :
 - Axial : ± 10 mm, ± 4 g,
 - Radial : ± 6 mm, ± 2.5 g.
- Operating temperature :
 - up to $+ 80^{\circ}\text{C}$.
- Salt spray protection 400 h. for external aluminium metalwork.

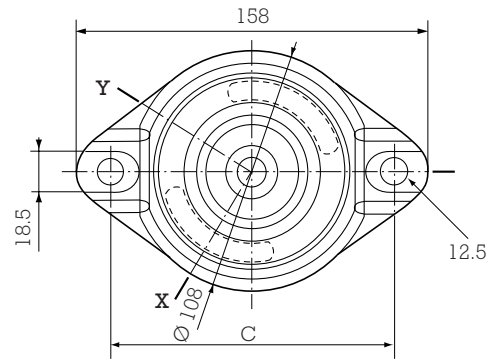
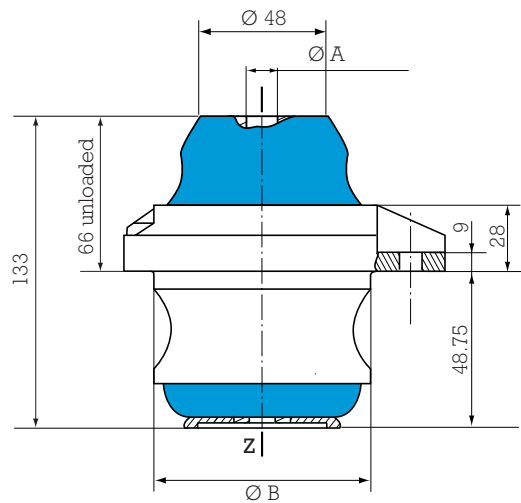

Mounting :

Reference	Ø A mm	Ø B mm	C mm
905233	12.4	94	128

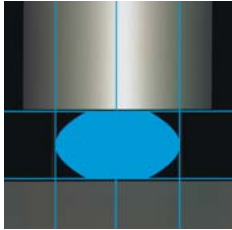

ENGINE MOUNTINGS



(1) Natural frequency:
6 Hz



DESCRIPTION

This engine mounting is made of one conical elastomeric element enclosed in a cast iron assembly. A built-in adjustable stop limits the vertical and lateral displacement during shock. This mount is available in four different alternatives depending on the type of upper fixing needed.

It can be supplied with or without levelling system and with a threaded hole or a threaded stud.

OPERATION

This mount has been designed to suspend fixed or mobile generators which require a high level of vibration isolation and shock protection. The load per mount varies from 600 kg to 2300 kg. This load range is covered by 5 different variants (12 to 16) clearly identified by a coloured marking (see table).

This mount is available in four different alternatives depending on the type of upper fixing needed:

- 905201: No levelling system - M24 x 3.00 threaded hole
- 905202: Built-in levelling system - M24 x 3.00 threaded hole
- 905203: No levelling system - M24 x 3.00 threaded stud
- 905206: Built-in levelling system - M24 x 3.00 threaded stud

Note: Please refer to the drawings overleaf for more details on the different types of mounts.

(1) Natural frequencies with max/min loads, see: OPERATING CHARACTERISTICS.

OPERATING CHARACTERISTICS AND DIMENSIONS

- Load range :
Please refer to the chart below for the different variants and their colour marking.
- Deflection under static load :
8 to 10 mm which gives a natural frequency around 6 Hz.
- Maximum displacement :
Vertical (Axial) : ± 6 mm.
Lateral (Radial) : ± 5 mm.
- Ultimate load :
Vertical (Axial) : ± 4 g.
Lateral (Radial) : ± 3 g.
- Operating temperatures :
- 10°C up to + 70°C.
- Unit weight :
11.5 to 12.8 kg (depending on the variant).

Load range	Variant	Color
600 - 850 kg	12	White
850 - 1150 kg	13	Yellow
1100 - 1450 kg	14	Green
1400 - 1900 kg	15	Blue
1700 - 2300 kg	16	Purple

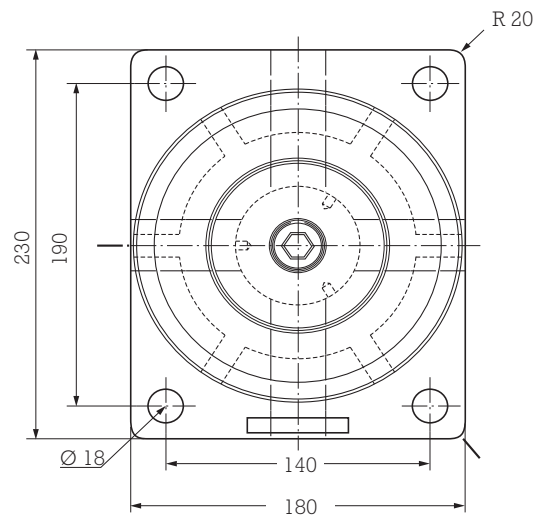
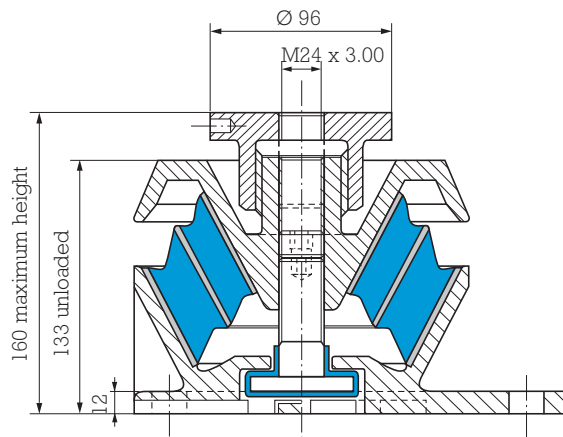

Reference 905202

ASSEMBLY

The installation of these mounts and the adjustments of their limit stops once loaded are detailed in an assembly procedure supplied with the mounts.

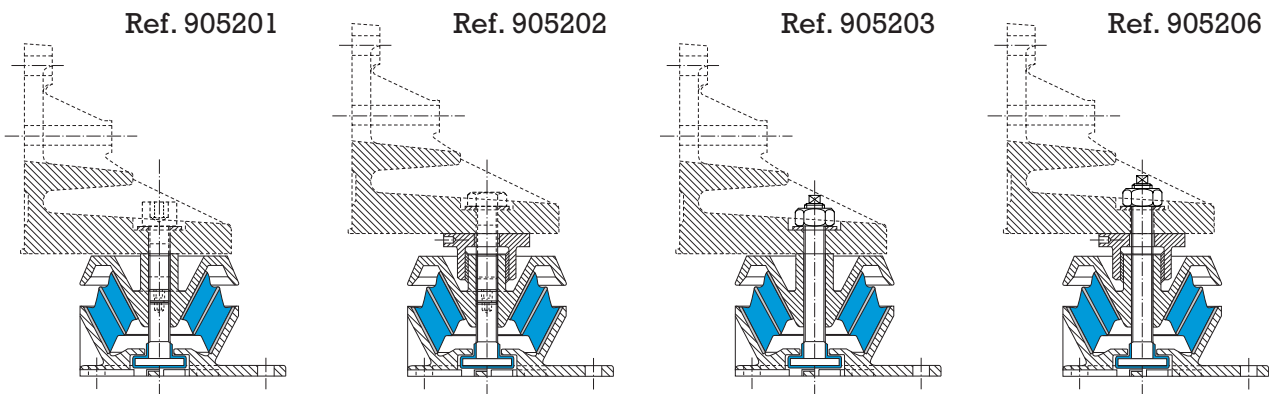

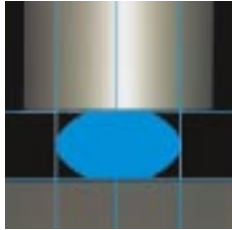

S.C. MOUNTING



(1) Natural frequency :
6 to 30 Hz

DESCRIPTION

The S.C. mounting comprises an annular section bonded between the inner tube and outer housing.
The outer housing has a mounting flange (4 different types).

OPERATION

The design of the S.C. mounting gives the following basic characteristics :

- Axial elasticity four times higher than radial elasticity.
- The rubber works in shear.
- Progressive buffer against shocks or accidental overload, provided that a large metal washer is used to bear against the rubber dome.
- Can be used as a fail safe assembly when fitted as in figure 1.

Advantages :

- Extensive range : 3 hardnesses of rubber for 20 existing types, allowing the mounting to be optimised as a function of the load and exciting frequency.

Recommendations :

- In order not to affect the performance of the mounting system, all external connections must be flexible.
- S.C. mountings must be fitted so that the vibration input is in the axial direction.

(1) Natural frequencies with max/min loads, see : OPERATING CHARACTERISTICS.

DIMENSIONS

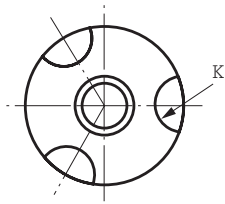
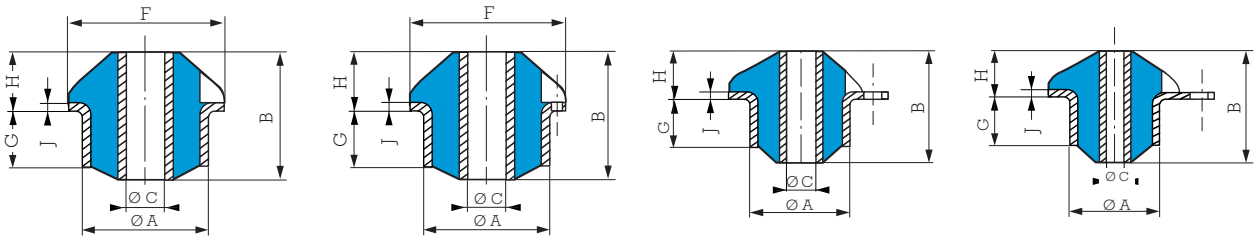

Fig. a

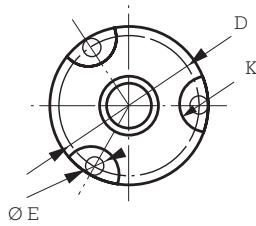

Fig. b

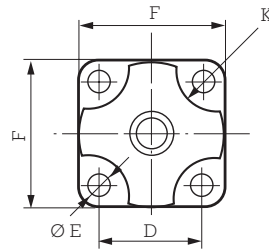

Fig. c

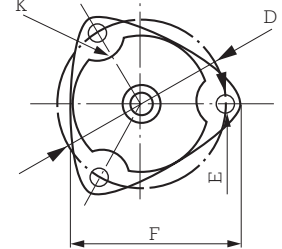

Fig. d

TYPE	Reference				Ø A mm	B mm	Ø C mm	D mm	E mm	F mm	G mm	H mm	J mm	K mm	Weight g
	With fixing holes	Without fixing holes													
S.C. 000	531201	Fig. c	--	--	20	11	6.2	19	3.2	25	3	7	1	4	8
S.C. 00	531301	Fig. c	--	--	26	28	8	26	5.2	36	12.5	11.5	1.5	12	40
S.C. 01	--	--	531401	Fig. a	37.5	40	12.1	--	--	48	18	18	2	8	110
S.C. 02	--	--	531402	Fig. a	37.5	51	12.1	--	--	48	24	18	2	8	130
S.C. 10	531216	Fig. d	--	--	49.1	47	12.2	69	8.2	72	20	18	2	12	190
S.C. 11	531611	Fig. d	--	--	49.1	60	12.2	69	8.2	72	31	18	2	12	290
S.C. 20	--	--	531701	Fig. a	55.7	55	18.2	--	--	70	27	19	3	10	370
S.C. 21	--	--	531702	Fig. a	55.7	70	18.2	--	--	70	39	19	3	18	480
S.C. 21	531240	Fig. d	--	--	57.2	70	18.2	86	10.5	90	39	19	3	18	500
S.C. 30	531259	Fig. b	--	--	65	75	20.2	78	8.5	90	29	28	3	18	560
S.C. 31	531261	Fig. d	--	--	66.5	93	20.2	95	8.5	107	47	28	3	18	780
S.C. 40	531714	Fig. d	--	--	76	90	22.2	100	8.5	112	42	28	3	18	880
S.C. 41	531327	Fig. d	--	--	76	110	22.2	100	8.5	112	49	28.5	3	18	960
S.C. 50	531939	Fig. d	--	--	87.5	100	40.2	114	8.5	127	47	33	3	20	1300
S.C. 51	531947	Fig. b	--	--	86	120	40.2	104	10.5	120	63	33	3	20	1500
S.C. 70 red.	531933	Fig. b	--	--	118	98	60.2	145	10.5	164	36	46	4	22	2200
S.C. 70	531932	Fig. b	--	--	118	140	60.2	145	10.5	164	66	46	4	22	3000
S.C. 71	531931	Fig. b	--	--	118	170	60.2	145	10.5	164	96	46	4	22	3800
S.C. 80	531940	Fig. b	--	--	170	167	80	204	12.2	230	95	53	5	30	7100
S.C. 81	531941	Fig. b	--	--	170	185	80	204	12.2	230	113	53	5	30	7700

See current price list for availability of items.

OPERATING CHARACTERISTICS

Nominal static load daN	Deflect. mm	Reference	Hard.	Nominal static load daN	Deflect. mm	Reference	Hard.	Nominal static load daN	Deflect. mm	Reference	Hard.
1-6	1	531201	45	35-150	1.5	531611	75	110-440	3.5	531939	60
2-8	0.8	531201	60	35-150	3	531701	60	110-450	3	531327	75
2-10	0.5	531201	75	40-175	5	531259	45	110-450	6.5	531933	45
5-20	1.5	531301	45	45-180	2	531701	75	135-550	2.5	531939	75
7-30	1.2	531301	60	45-190	3	531240	60	135-550	3.5	531947	60
10-40	0.8	531301	75	45-190	3	531702	60	150-600	5	531933	60
10-50	2.5	531401	45	55-225	5	531714	45	165-670	2.5	531947	75
15-65	1.8	531401	60	60-240	3.5	531259	60	175-700	6.5	531932	45
15-65	2.5	531402	45	60-250	2	531240	75	210-850	6.5	531931	45
15-70	4	531216	45	60-250	2	531702	75	225-900	5	531932	60
20-80	1.5	531401	75	60-250	5	531261	45	275-1100	3	531932	75
20-85	1.8	531402	60	60-250	5	531327	45	275-1100	5	531931	60
20-85	4	531611	45	75-300	2	531259	75	310-1250	11	531940	45
25-100	3	531216	60	80-320	4.5	531714	60	350-1400	3	531931	75
25-100	3.5	531701	45	80-325	4.5	531939	45	400-1600	11	531941	45
25-110	1.5	531402	75	85-350	3.5	531261	60	450-1800	8.5	531940	60
30-120	2	531216	75	90-360	4.5	531327	60	525-2100	8.5	531941	60
30-120	3	531611	60	95-380	3	531714	75	575-2300	5	531940	75
30-135	3.5	531240	45	100-400	4.5	531947	45	650-2600	5	531941	75
30-135	3.5	531702	45	105-420	2	531261	75				

1 kg ≈ 1 daN

LOAD/DEFLECTION CURVES IN AXIAL COMPRESSION

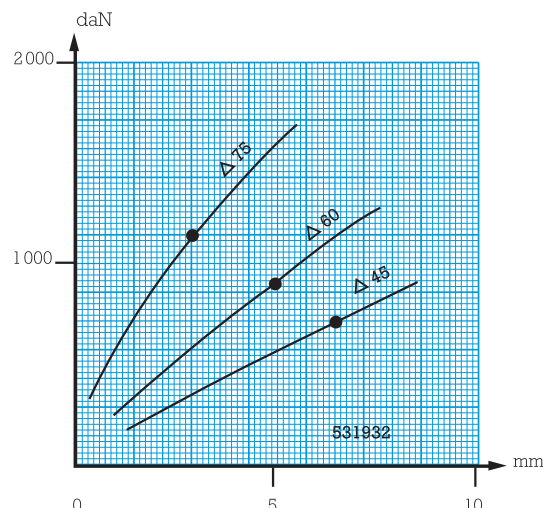
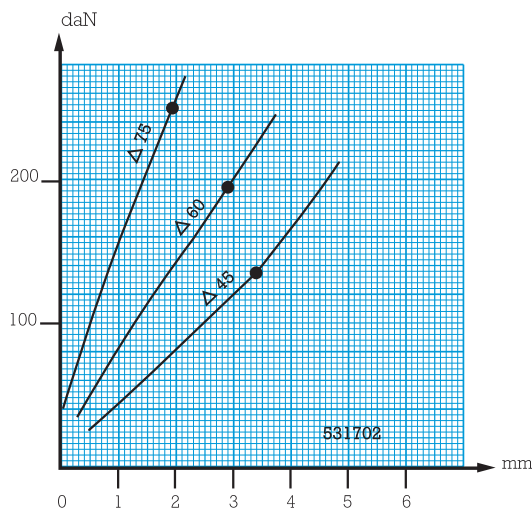
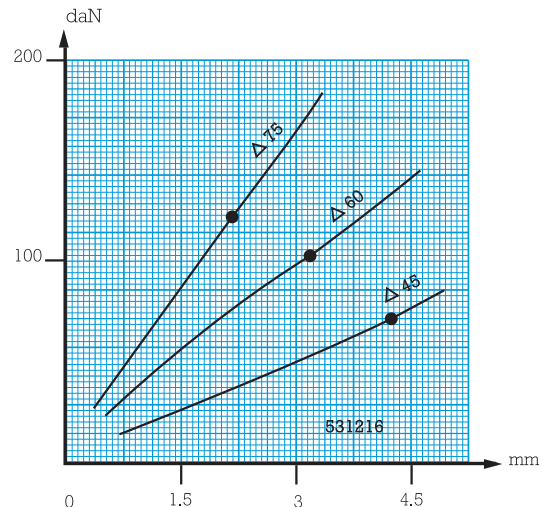
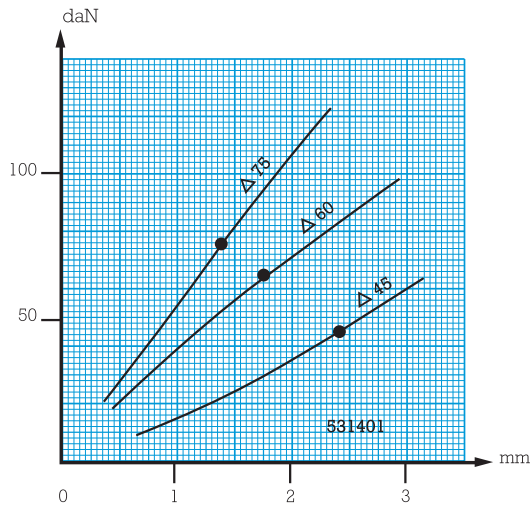

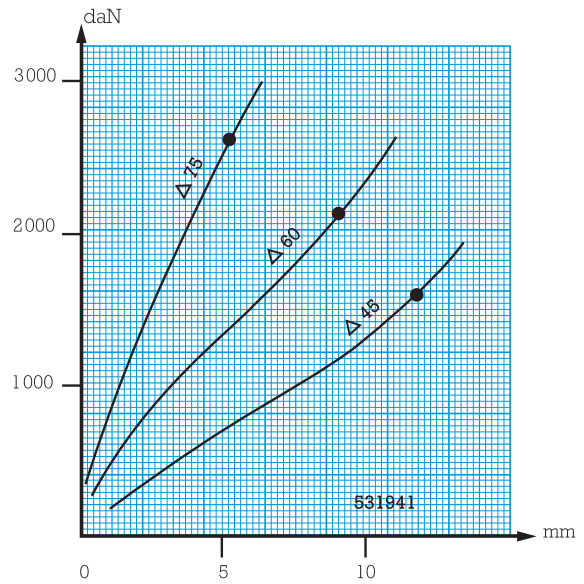
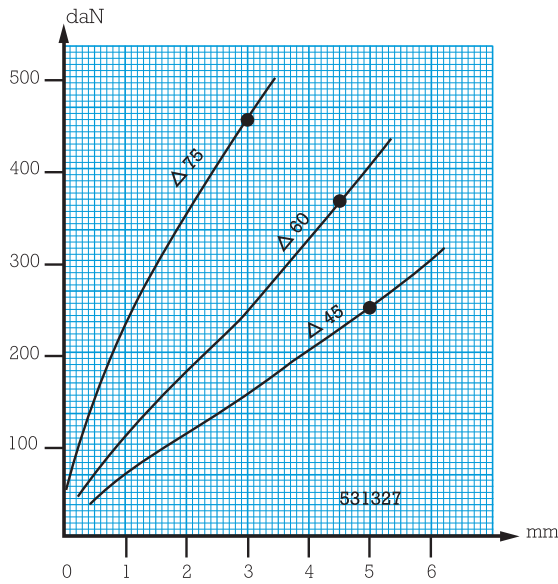

ASSEMBLY

• Standard fixing

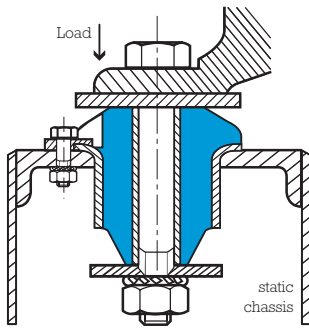

Fig. 1 - Fixing between the equipment and a metallic chassis (failsafe in mobile applications).

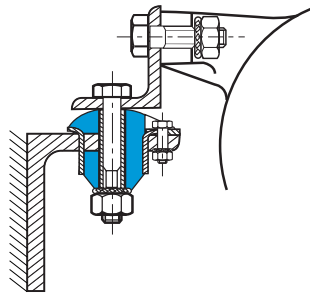

Fig. 2 - Fixing between two brackets onto a vertical surface (non failsafe).

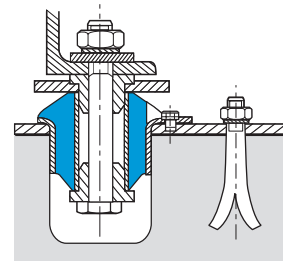

Fig. 3 - Fixing between the equipment and concrete (using locating rings).

• Reversed fixing

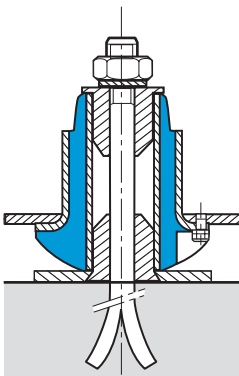

Fig. 4

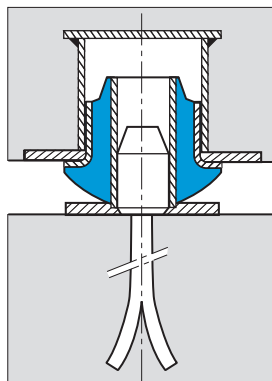

Fig. 5 - Fixing between inertia base and foundation. The inertia base increases the suspended mass and thus reduces the amplitudes of the vibrations as well as lowering the natural frequency.

• Mounting in tandem

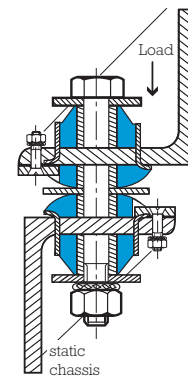
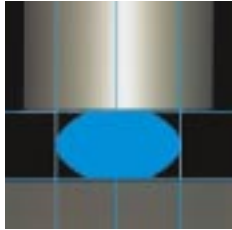

Fig. 6 - Two mountings fixed face to face. Provides twice the deflection under the same load.



EVIDGOM®



(1) Natural frequency :
2.5 to 7 Hz

DESCRIPTION

The EVIDGOM mounting is formed from two thick conical membranes, joined at their bases to create a highly elastic mounting.

There are three variations :

- All rubber EVIDGOM.
- EVIDGOM with bonded fixing.
- EVIDGOM with a diamond or square mounting plate (fixing plate supplied as a separate kit).

OPERATION

The design of the EVIDGOM mounting gives the following basic characteristics :

- A very high axial elasticity.
- Very low natural frequency (a few Hertz).
- Progressive buffer against shocks or accidental overload.

Advantages :

- As the load/deflection curve has a point of inflection, a suspension may be designed to have a sub-tangent greater than the static deflection.
- The elastomer used provides intrinsic damping with a corresponding ability to absorb energy which gives appreciable advantages over metallic springs.

Recommendations :

- The selection of a low natural frequency (large deflection) must not be allowed to endanger the stability of the suspension (tall equipment).
- In certain cases (use under maximum load) the use of side stops is recommended.

(1) Natural frequencies with max/min loads, see : OPERATING CHARACTERISTICS.

DIMENSIONS

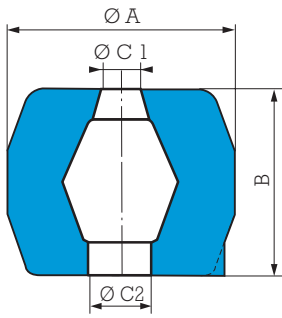

Fig. 1

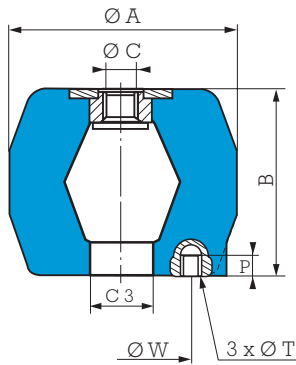

Fig. 2

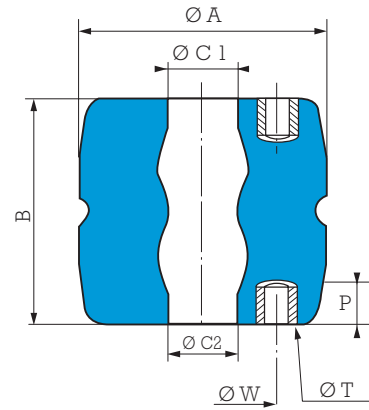

Fig. 3

Ø A mm	B mm	Evidgom reference				Ø C	Ø C ₁ mm	Ø C ₂ mm	Ø C ₃ mm	Ø W mm	Ø T	P mm
		All rubber	Fig.	With fixings	Fig.							
34	25	810002	1				8	8				
40	55	810003	1				14	14				
50	70	810005	1				14	14				
60	40			810780	2	M10		25	25	40	M6	6
85	70	810006	1	810766	2	M16	20	30	30	60	M8	8
95	90	810008	1	810768	2	M16	20	30	30	60	M8	8
108	90	810009	1	810769	2	M16	20	30	34	70	M10	10
120	110	810012	1				20	30				
140	120	810013	1	810773	2	M16	25	40	35	70	M10	10
125	140	810014	1	810784	2	M16	25	30	25	70	M10	10
140	90	810019	1	810779	2	M16	28	12	28	70	M10	10
140	56	810020	1	810770	2	M16	30	30	30	70	M10	10
155	150	810015	1	810775	2	M16	25	30	30	90	M14	14
188	180	810016	1	810776	2	M24	40	40	40	90	M14	14
250	230	-	-	810733	3	-	70	70		150	6 X M24	40
350	290	-	-	810736	3	-	85	85		196	8 X M24	40

See current price list for availability of items

Lower fixing plate

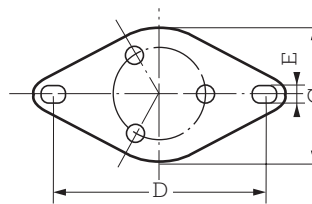
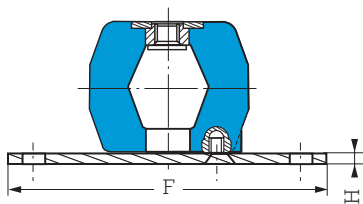

Fig. a

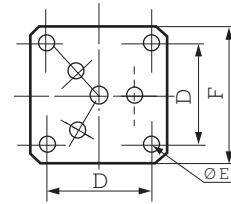

Fig. b

Evidgom reference	Fixing pack reference	Fig.	D mm	E mm	F mm	G mm	H mm
810780	337566	a	98/102	8.2	117	65	5
810766	337567	a	124/128	10.2	158	110	5
810768	337567	a	124/128	10.2	158	110	5
810769	337568	a	178/182	10.2	214	150	6
810773	337568	a	178/182	10.2	214	150	6
810784	337568	a	178/182	10.2	214	150	6
810779	337568	a	178/182	10.2	214	150	6
810770	337568	a	178/182	10.2	214	150	6
810775	337569	b	170	10.5	200	-	8
810776	337569	b	170	10.5	200	-	8

OPERATING CHARACTERISTICS

Nominal static load daN	Deflect. $\pm 15\%$ mm	\varnothing A mm under nominal charge	Height B mm	Reference
5-15	5	40	25	810002
10-40	11	50	55	810003
20-80	14	63	80	810005
15-60	10	80	40	810780
25-100	15	105	70	810766
35-150	18	124	90	810768
100-400	20	136	90	810769
100-390	23	134	110	810012
150-600	24	175	120	810773

Nominal static load daN	Deflect. $\pm 15\%$ mm	\varnothing A mm under nominal charge	Height B mm	Reference
200-800	26	170	140	810784
200-800	16	175	90	810779
200-800	10	166	56	810770
325-1300	30	175	150	810775
500-2000	35	240	180	810776
1250-5000	50	345	230	810733Δ60
2000-8000	50	345	230	810733Δ75
2250-9000	60	500	290	810736Δ60
3500-14000	60	500	290	810736Δ75

See current price list for availability of items.

LOAD/DEFLECTION CURVES IN AXIAL COMPRESSION

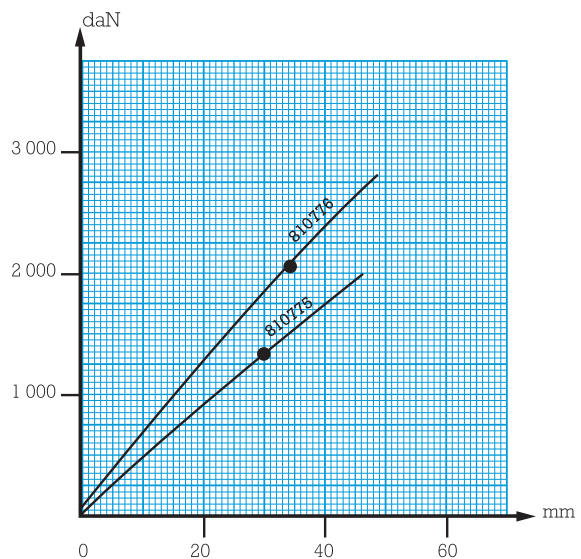
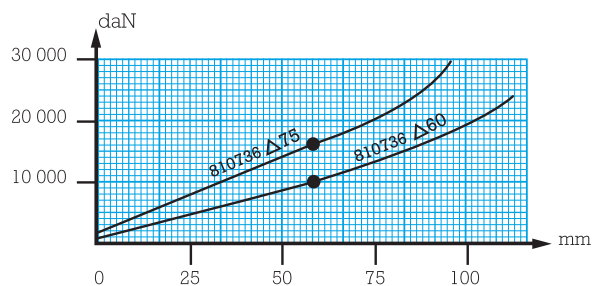
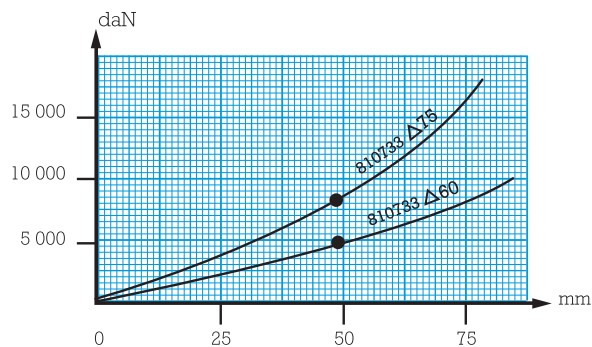
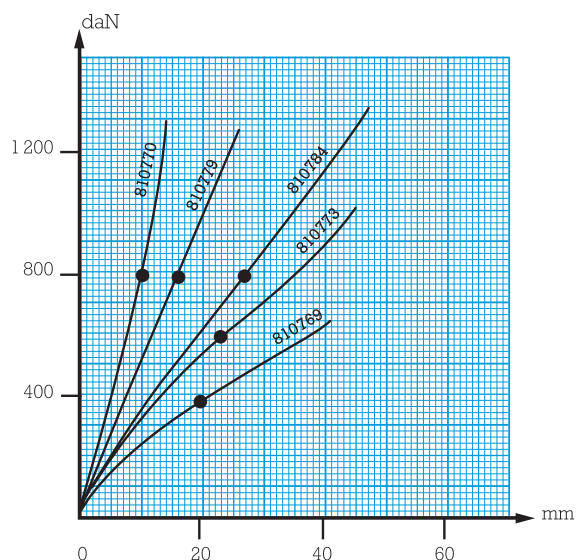
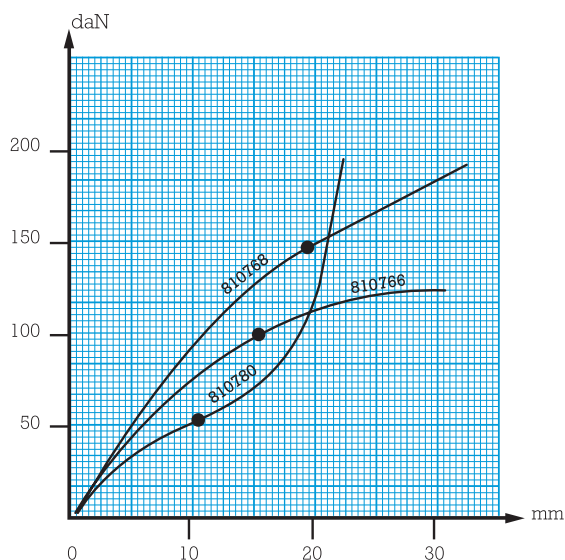

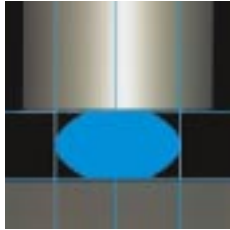

S.T.C.



(1) Natural frequency :
10 to 25 Hz

DESCRIPTION

The S.T.C. mounting comprises a rubber ring bonded to a central tube.

- Inner tube : mild steel.
- Bonded rubber in the form of a ring at the top with a collar below which is used for fixing.

OPERATION

The design of the S.T.C. mounting gives the following basic characteristics :

- The rubber works in compression.
- Anti-rebound.
- Can be used as safety mounting.

Advantages :

- Simple to fix.
- Simple and economical.
- Extensive range of loads.

(1) Natural frequencies with max/min loads, see : OPERATING CHARACTERISTICS.

DIMENSIONS

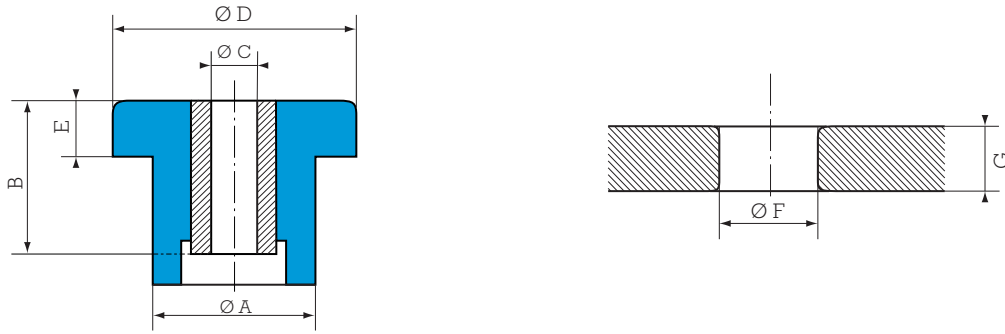

Reference	Ø A mm	B mm	Ø C mm	Ø D mm	E mm	Ø F mm	G mm
539887	20.6	17.5	10	27.7	5.6	20.6	8
539190	31.5	25.4	13	44.5	10.4	31.5	10
539886	34.3	35	13	50.8	13.5	34.3	16
539191	41.1	44.5	16	63.5	15.7	41.1	19
* 539920	38	23	16	64	16	38.5	19
539951	56.6	50.8	20	95	25.4	56	20

* This S.T.C. is mounted in pairs : see Fig. 2.

See current price list for availability of items.

OPERATING CHARACTERISTICS

Reference	Hardness	Nominal static load daN	Deflection mm
539887	45	8-35	0.7
	60	10-50	0.7
539190	45	15-75	1.2
	60	25-100	1.2
539886	60	35-150	1.2
	75	80-330	1.2

Reference	Hardness	Nominal static load daN	Deflection mm
539191	60	60-250	2
	75	125-500	2
539920	45	100-400	2
	75	250-1000	1
539951	45	175-700	3
	65	250-1000	3

ASSEMBLY

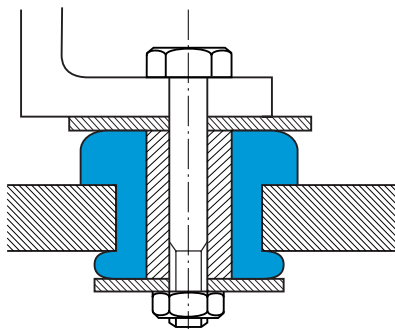

Fig. 1

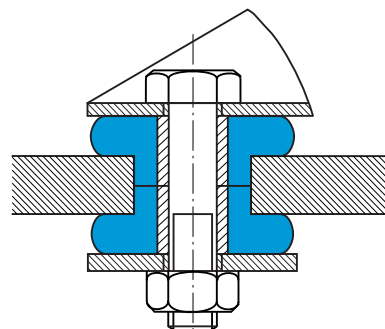
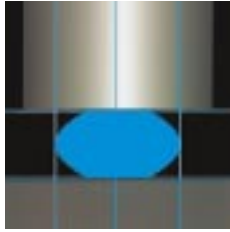
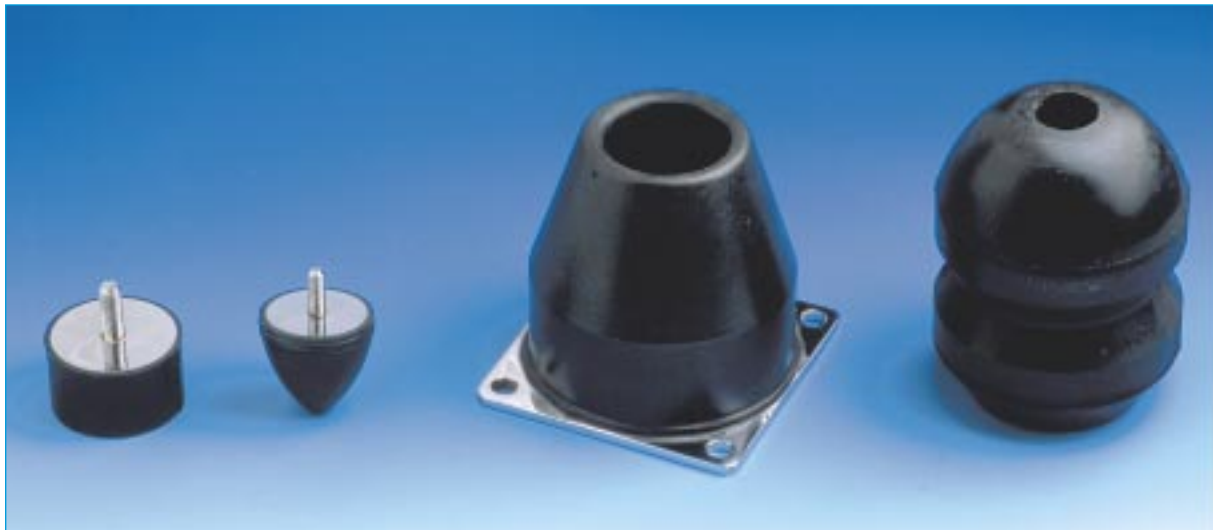

Fig. 2 (For 539920)



STOPS

See : Supports and
Bump stops



Cylindrical stop

Conical progressive
stop

LEVAFLEX progressive
stop

EVIDGOM stop

DESCRIPTION

There are several types of stops :

- Cylindrical or DIABOLO stops.
- Conical progressive stops.
- LEVAFLEX progressive stops with central cavity.
- EVIDGOM stops.

OPERATION

The design of the PAULSTRA elastic stops gives the following basic characteristics :

- Highly deformable allowing high energies to be absorbed.
- Progressive absorption of energy due to the carefully designed shape.

Advantages :

- By comparison with rigid stops, PAULSTRA elastic stops are quiet and avoid hammering and deterioration of equipment.

Recommendations :

- The stops must be fitted so that, on impact, the axis of the stop is perpendicular to the contact surface.
- On impact, the external diameter of the stop increases : this must be allowed for when fixing.

DIMENSIONS AND OPERATING CHARACTERISTICS

CYLINDRICAL STOPS

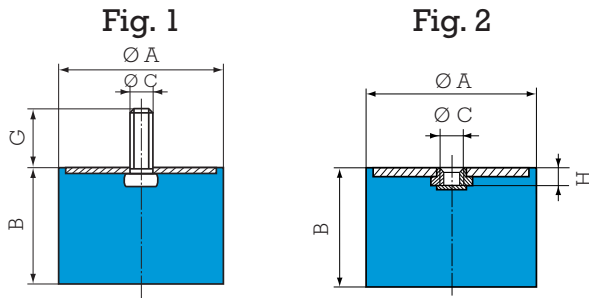

New range RADIAPLEX

Ø A mm	B mm	Ø C	G mm	Fig.	H mm	Max. load daN	Deflect mm	Energy Joules	Reference
12.5	10	M5	10	1	-	12	2	0.12	511110
	13.5					2.5	0.13	511128	
	15					3	0.16	511115	
	20					3.5	0.14	511125	
16	10	M4	-	1	-	20	2	0.20	511150
	15					3	0.30	511151	
	10					2	0.20	511152	
	15					2	0.30	511153	
16	10	M5	12	1	-	20	2	0.20	511292
	15					3	0.30	511294	
	20					4	0.30	511296	
	25					5	0.30	511298	
20	15	M6	-	2	4	35	4	0.70	511154
	8.5					40	1.5	0.30	511200
	15					35	4	0.70	511215
	20					30	5	0.70	511220
20	25	M6	16.5	1	-	30	5	0.70	511225
	30					5.5	0.80	511225	
	30					7	0.80	511230	
	30					7	0.80	511230	
25.5	10	M6	18	1	-	80	2	0.80	511158
	15					3.5	1.00	511155	
	20					5	1.20	511159	
	30					8	2.00	511160	
25.5	15	-	-	2	4	60	3.5	1.00	511164
	20					4	1.20	511162	
	30					4	2.00	511163	
	30					4	2.00	511163	

Ø A mm	B mm	Ø C	G mm	Fig.	H mm	Charge maxi daN	Deflect mm	Energy Joules	Reference
25.5	10	M8	20	1	-	80	2	0.80	511265
	15					3.5	1.00	511270	
	19					4.5	1.20	511251	
	22					5.5	1.30	511275	
	25					6	1.50	511280	
	30					8	2.00	511285	
30	22	M8	-	2	6	80	6	2.40	511156
	15					90	3.5	1.50	511308
	22					80	6	2.40	511310
	30					70	8	2.80	511312
	40					60	9	2.70	511314
	40					30	M8	20	1
40		120	10	6.00	511161				
20		160	5	4.00	511450				
25		150	6	4.50	511401				
35		120	8	4.80	511452				
40		120	10	6.00	511454				
50	45	M10	25	1	-	120	11	6.60	511456
	25					300	6	9.00	511525
	35					250	9	11.20	511535
60	45	M10	25	1	-	190	11	10.00	511545
	25					400	6	12.00	511625
	36					300	9	13.50	511635
70	45	M10	25	1	-	250	11	13.70	511645
	35					450	9	20.00	511735
	50					350	12	21.00	511750
80	70	M10	25	1	-	300	14	21.00	511770
	25					1100	6	33.00	513801
	30					950	8	38.00	511830
80	30	M14	45	1	-	35	10	30.00	511840
	35					600	10	30.00	511840
	70					500	17	42.50	511870
	35					450	19	43.00	511880

See current price list for availability of items.

CONICAL PROGRESSIVE STOPS

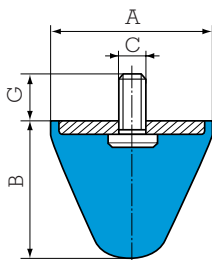

Reference	Ø A mm	B mm	Ø C	G mm	Repetitive shocks			Exceptional shock Energy joules	Wght g
					Energy Joules	Deflect. mm	Reaction daN		
512251	25.5	19	M8	20	3	8	100	9	20
512307	30	30	M8	25	6	15	140	18	37
512301	30	30	M6	13.5	6	15	140	18	30
512515	50	50	M10	25	30	25	340	90	85
512501	50	50	M8	20	30	25	340	90	75
512516	50	64	M10	25	40	32	370	120	150
512502	50	64	M8	35	40	32	370	120	150
512517	50	58	M10	25	37	28	400	110	130
512503	50	58	M8	15	37	28	400	110	120
512608	60	40	M10	25	27	18	550	70	140
512601	60	40	M14	62	27	18	550	70	200
512700	72	58	M10	25	50	26	550	150	290
512721	72	58	M12	30	50	26	550	150	300
512951	95	80	M16	45	120	37	1100	350	750

See current price list for availability of items.

DIABOLO STOPS

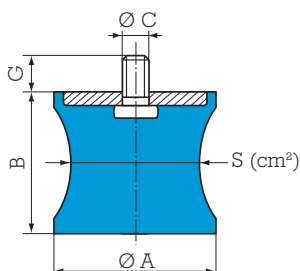

Reference	S cm²	Ø A mm	B mm	Ø C	G mm	Max. instant. load daN	Deflect. mm	Max. static load daN	Deflect. mm	Energy Joules	Wght g
511571	5	57	42	M8	20	100	10	40	4	1	60
511572	9.5	57	42	M8	20	200	12	75	5.5	2	80
511601	19.5	60	57	M10	25	350	15	150	8	6	190
511801	38.5	80	65	M14	30	800	16	300	9.5	15	500
511951	50	95	70	M16	35	1000	18	400	9.5	20	790

See current price list for availability of items.



LEVAFLEX PROGRESSIVE STOPS

Reference	A mm	B mm	Ø C mm	D mm	Ø E mm	Ø G mm	H mm	Weight g
514085	85	85	8.5	69	8.5	20	5	600
514110	110	110	12.5	90	8.5	30	6	1200
514130	130	130	19	106	11	40	6	2000
514160	160	160	23	132	11	45	8	3000
514200	200	200	28	168	13	60	10	7000

See current price list for availability of items.

Repetitive shocks			Exceptional shock energy Joules	Reference hardness
Energy Joules	Corresponding deflection mm	Reaction daN		
170	40	1200	500	514085/60
280	40	1700	850	514085/75
330	50	1800	1000	514110/60
550	50	3400	1500	514110/75
600	65	2800	1800	514130/60
650	60	3000	1900	514130/75
1050	75	4500	3000	514160/60
1200	90	4000	3600	514200/60
1300	70	6000	3900	514160/75
2200	85	7800	6600	514200/75

1 kg ≈ 1 daN

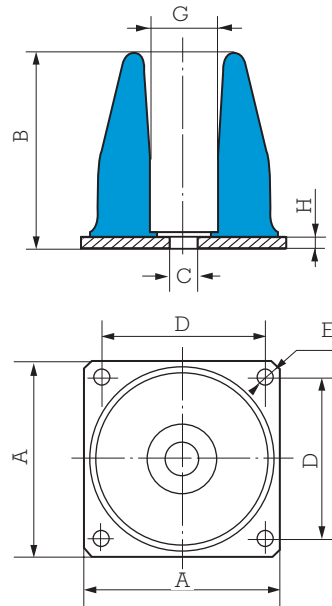

EVIDGOM STOPS

Repetitive shocks			Exceptional shock energy Joules	Reference hardness
Energy Joules	Corresponding deflection mm	Reaction daN		
31	30	190	95	810644
100	50	580	300	810645
110	45	600	330	810666
180	67	750	540	810642
350	75	1250	1050	810653
360	65	1400	1100	810655
400	85	1500	1200	810669
300	70	900	--	810784
600	75	1625	--	810775
1050	90	2375	--	810776
2500	90	5500	--	810733/60
7100	150	11000	--	810732/60
9500	200	9500	--	810731/60
13000	130	18000	--	810732/75
17500	175	19000	--	810731/75
21000	200	25000	--	810735/60
29000	250	35000	--	810734/60
41000	200	70000	--	810735/75
50000	250	55000	--	810734/75

1 kg ≈ 1 daN

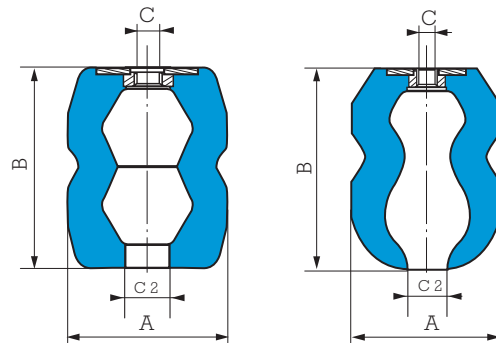

Fig. 1

Fig. 2

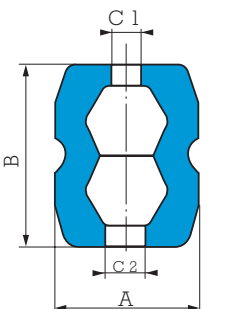

Fig. 3

Stop reference	Fig.	All rubber Evidgom reference	Ø A mm	B mm	Ø C	Ø C ₁ mm	Ø C ₂ mm	Ø D mm	Ø A under load mm
810642	1	810022	85	120	M16	20	30	--	114
810644	1	810004	55	55	M10	14	14	--	72
810645	2	810035	66	93	M16	20	14	--	100
810653	1	810023	100	130	M16	20	30	--	140
810655	1	810025	110	132	M16	20	30	--	142
810666	2	810046	76	90	M16	20	14	--	98
810669	2	810029	110	150	M16	20	30	--	155
810731	3	--	250	400	6 X M24	70	70	150	360
810732	3	--	250	315	6 X M24	70	70	150	380
810733	3	--	250	230	6 X M24	70	70	150	370
840734	3	--	350	500	8 X M24	85	85	196	445
810735	3	--	350	395	8 X M24	85	85	196	500
810775	1	810015	155	150	M16	25	40	--	202
810776	1	810016	188	180	M24	40	30	--	256
810784	1	810014	125	140	M16	30	25	--	168

NOTE: The values are given for test conditions with an impact speed of 1 m/s. Consult us for speeds that are much higher.



DEFLECTION CURVES AND ENERGY VALUES FOR PROGRESSIVE, LEVAFLEX AND EVIDGOM STOPS (Pages 61 and 62)

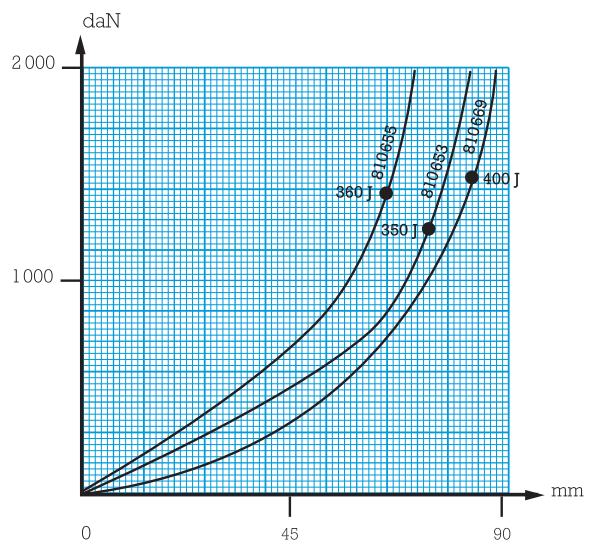
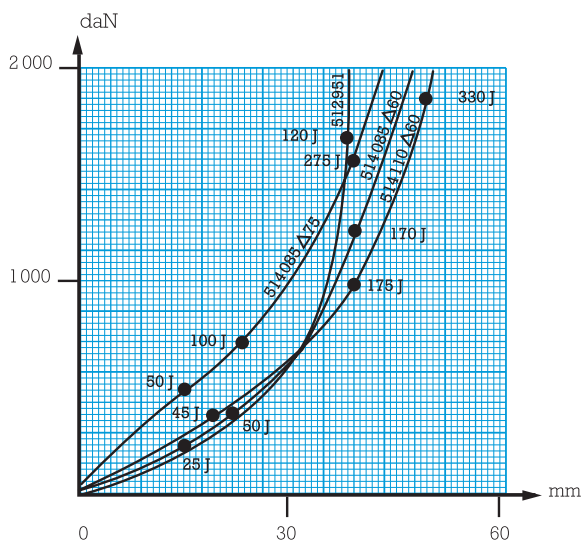
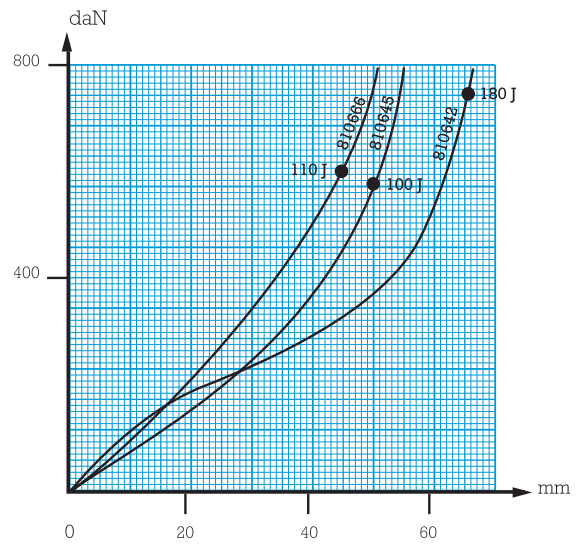
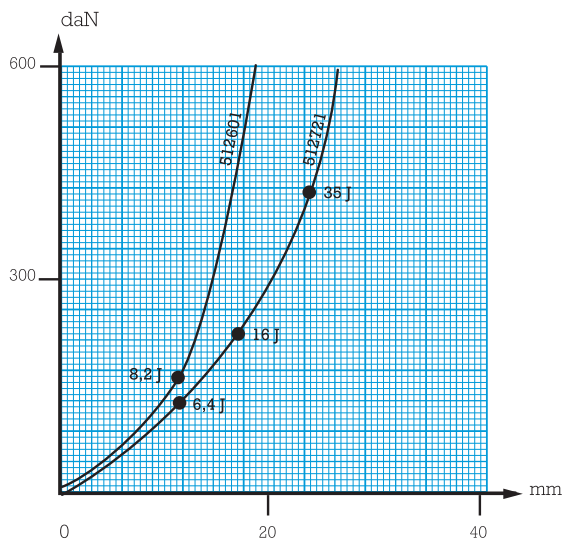
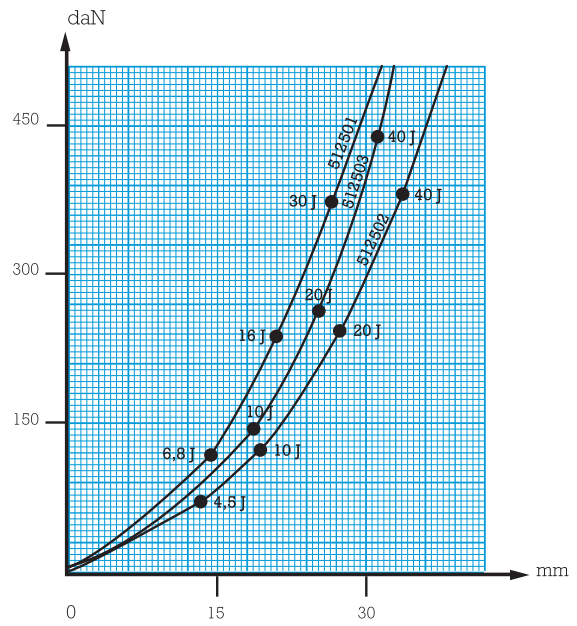
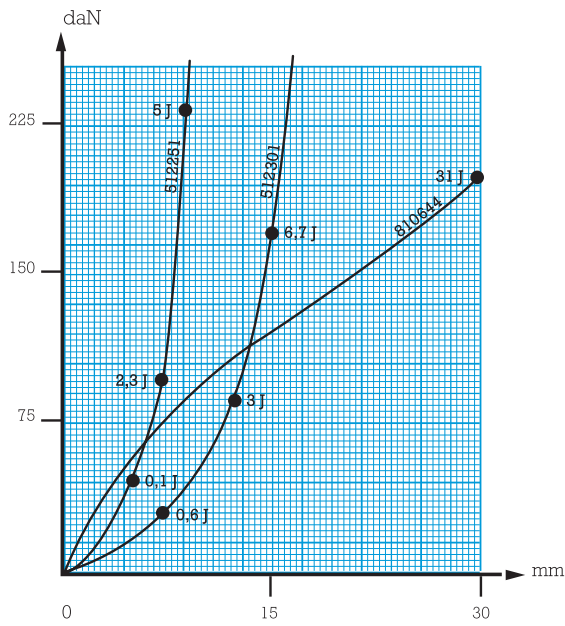

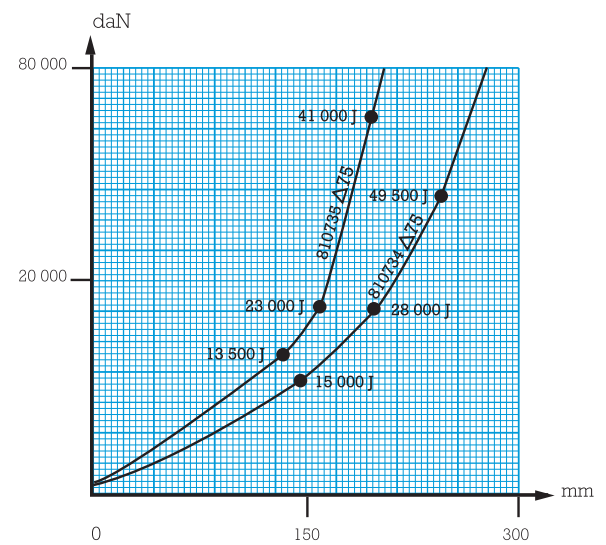
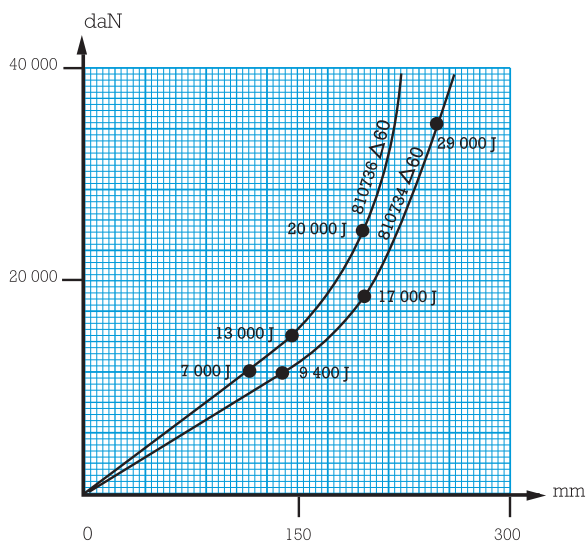
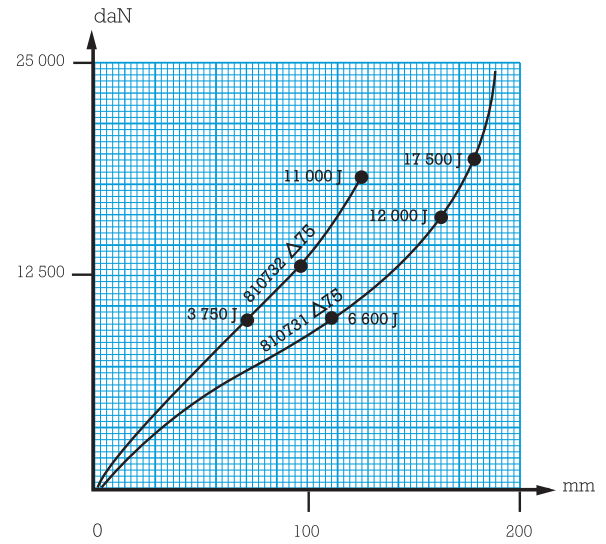
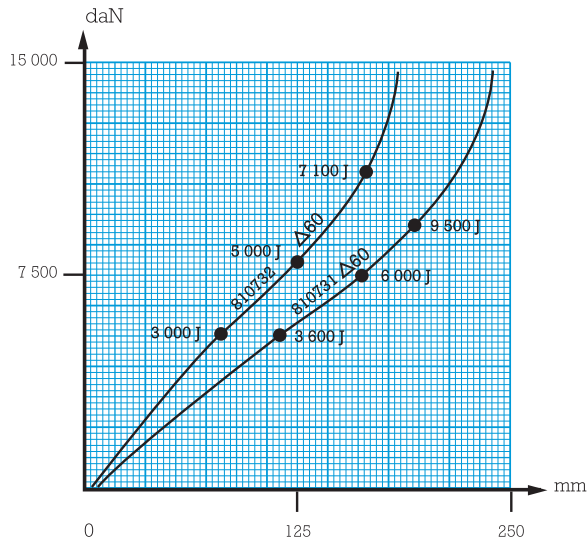
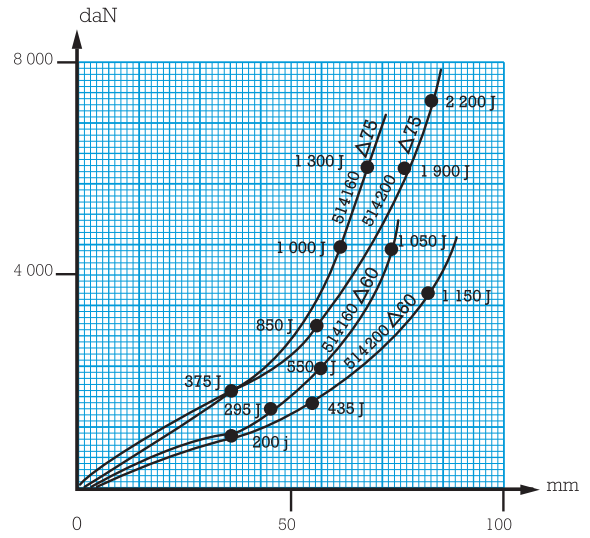
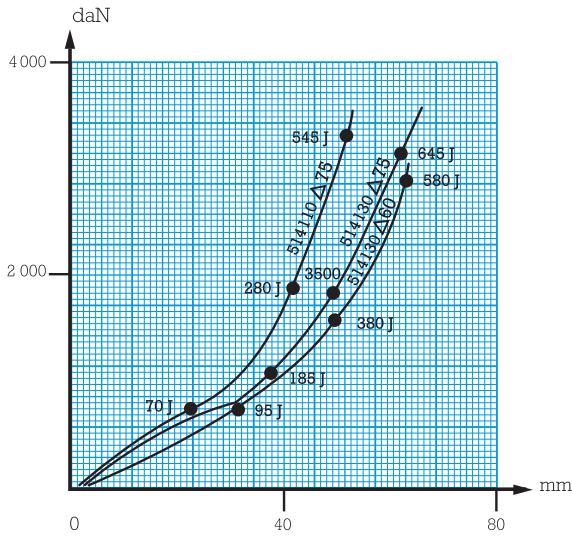

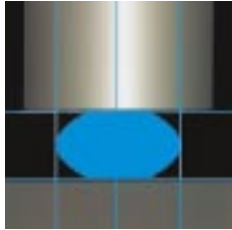

NIVOFIX®

See Vibrachoc
metallic range :
V43 - V44 - V45 - V46



DESCRIPTION

The NIVOFIX mounting is an adjustable equipment foot comprising a circular disc bonded to a protected elastomer base. An adjustment screw is fitted into the assembly.

The elastomer base has anti-slip ridges.

OPERATION

The design of the NIVOFIX mounting gives the following basic characteristics :

- Accurate adjustment of the mounting to correct the equipment's seating (adjustment screw, correction of altitude).
- Absorbs high frequency vibrations.
- Corrosion resistant (nitrile elastomer, protective shroud, galvanised metallic parts).
- Anti-slip sole (no need to fix).

Advantages :

- Speed of fixing.
- Simple removal of the equipment.
- No shimming.

DIMENSIONS

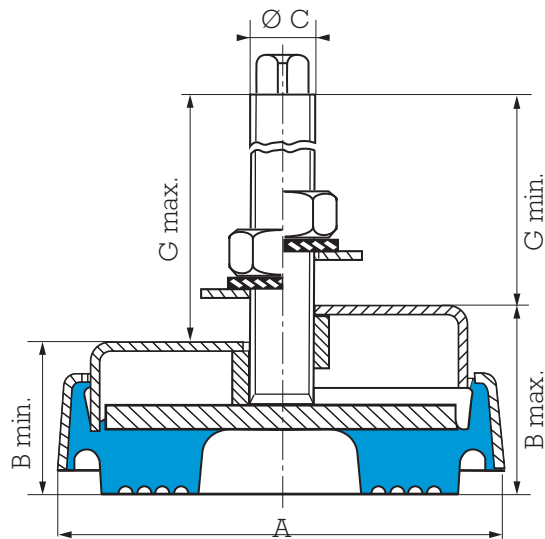

Reference Stainless steel	Reference Steel	A mm	B mm			Ø C	G mm		Weight g	Stud length mm
			B maxi = B mini + adjustment				mini	maxi		
530815	530810	65	31.5	26.5	5	M12	105	110	280	120
530825	530820	88	46	33	13	M16	114	127	690	200
530835	530830	133	58	46	12	M20	130	142	1820	250
	530840	200	70	58	12	M24	145	157	5250	300
	530850	260	83	65	18	M24	158	176	10000	300

See current price list for availability of items.

OPERATING CHARACTERISTICS

Reference	Nominal static load min - max in daN	Deflection mm
530810	100 - 600	1 - 3.5
530815	100 - 600	1 - 3.5
530820	325 - 1300	2 - 4
530825	325 - 1300	2 - 4

Reference	Nominal static load min - max in daN	Deflection mm
530830	650 - 2600	2 - 4
530835	650 - 2600	2 - 4
530840	1500 - 6000	1.5 - 3
530850	3000 - 12000	2 - 4

1 kg = 1 daN

APPLICATIONS

NIVOFIX mountings are used for all equipment requiring height adjustment.

Equipment already using NIVOFIX mountings:

- Vertical mill
- Mortiser
- Multichuck drill
- Sheet metal bender
- Polisher
- Press
- Plane
- Horizontal mill
- Lathe
- Office equipment
 - accounting
 - computing
- Packaging machine
- Test equipment
- Printing press
- Gear cutter
- Textile machinery



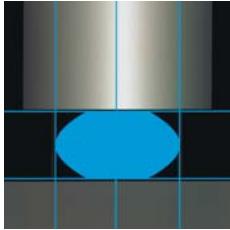

MINIFIX

New range
MINIFIX



DESCRIPTION

The MINIFIX mounting comprises an elastomer pad with an anti-slip ridged surface and a threaded stud allowing accurate height adjustment of equipment.

Made in two hardnesses (50 and 80 Sh) the MINIFIX mounting is perfectly suited to a variety of applications and is delivered complete with fixing nuts and washers. MINIFIX mounting nuts and screws are made of steel or stainless steel.

CHARACTERISTICS

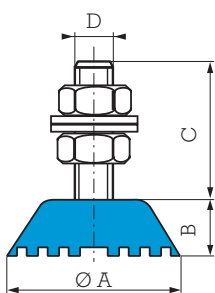

Reference Stainl. steel	Reference Steel	Hardness	Colour	Ø A mm	B mm	C mm	D	Load range daN
-	530801	50 SBR 80 Nitrile	grey black	32	15	38	M8 stud	5 - 30 15 - 70
-	530802*	50 SBR 80 Nitrile	grey black	46	15	-	M10 nut	10 - 80 25 - 200
530806	530805	50 SBR 80 Nitrile	grey black	46	15	38	M10 stud	10 - 40 25 - 100
-	530807	50 SBR 80 Nitrile	grey black	70	25.5	55.5	M12 stud	50 - 120 100 - 350

* Threaded centre hole.
See current price list for availability of items.

1 kg ≈ 1 daN

APPLICATIONS

Simple and economic, MINIFIX mountings are particularly suitable for the installation of equipment such as:

- Electrical or electronic enclosures.
- Packaging equipment.
- Test and measuring equipment.
- Equipment for the food industry.
- Laboratory equipment.
- Household appliances.



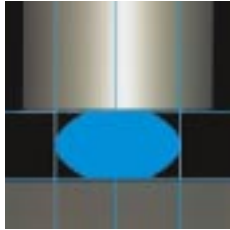

TRAXIFLEX

(1) Natural frequency :
8 to 10 Hz

See Vibrachoc
metallic range :
VE101 - VE111
VE112 - VE113



DESCRIPTION

The TRAXIFLEX mounting comprises two metallic U armatures joined by two bonded rubber blocks.
It is available in two versions : male/female and female/female.

OPERATION

The design of the TRAXIFLEX mounting gives the following basic characteristics :

- Rubber works in compression-shear.
- The same deflection under nominal load for all types.
- Positive safety in case of elastomer failure.

Advantages :

- Economic solution for suppressing structure borne noise.
- Several fixing methods.
- High resistance to atmospheric exposure :
 - galvanised armatures
 - chloroprene elastomer.
- Upper metallic part is shaped to simplify orientation while fixing.
- Two hardnesses of elastomer to extend the choice of mounting as a function of load.
- Filtration of vibration and the attenuation of the consequent noise.
- Allows movement due to thermal expansion.

(1) Natural frequencies with max/min loads, see : OPERATING CHARACTERISTICS.

DIMENSIONS

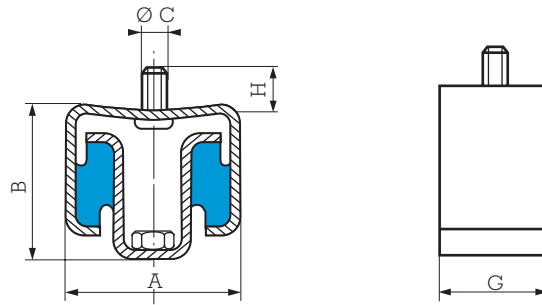

Type	Reference		Hardness	A mm	B mm	Ø C	G mm	H mm
	1 screw - 1 nut	2 nuts						
TR 12-30	535600*	--	45-60	47	38	M7 x 1.50	16	7
TR 12-30	53560361**	--	60	47	38	M6 x 1.00	16	17
TR 12-30	535603	--	45	47	38	M6 x 1.00	16	17
TR 40-80	535611	535621	45-60	55	47	M8 x 1.25	30	13
TR 100-250	535612	535622	45-60	74	50	M12 x 1.75	40	17

See current price list for availability of items.

* Mountings ref. 535600 are fitted with a screw which can accept "ATLAS" collars.

** The part 53560361 also exists with a longer stud, H = 17 mm in an elastomer resistant to fire M1 (suffix 11).

OPERATING CHARACTERISTICS

Recommended load daN	Deflection mm	Reference		Hardness
		1 screw - 1 nut	2 nuts	
4-18	4	535600	--	45
4-18	4	535603	--	45
7-30	4	535600	--	60
7-30	4	53560361**	--	60
10-52	4	535611	535621	45
20-80	4	535611	535621	60
20-92	4	535612	535622	45
30-136	4	535612	535622	60

1 kg ≈ 1 daN

TRAXIFLEX mountings have been subjected to acoustic trials at the Centre Expérimental de Recherches et d'Études du Bâtiment et des Travaux Publics which has given the PV nr. 554.6.078.

Note: For important loads, refer to solutions given page 30.** Elastomer resistant to fire M1 (Suffix 11).

ASSEMBLY

When fixing, ensure that all the TRAXIFLEX mountings are supporting the same load. It is necessary to ensure that they are all the same distance from the fixing surface (ceiling, girder, plank...).

TRAXIFLEX mountings can be used to suspend pipework: the whole assembly being fixed to the ceiling.

- Suspending hot air ducts.
- Suspending a fan unit and distribution ducts.
- Suspending a hot air generator with continuous airflow.
- Suspending an integral cased air conditioner.

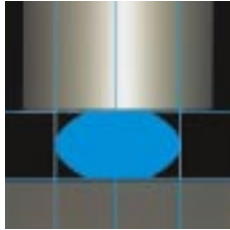

BATRA RING



(1) Natural frequency :
7 to 22 Hz

DESCRIPTION

The BATRA ring comprises a rubber ring bonded to two metallic washers one with a circular groove, the other with a mating circular ridge which allows BATRA rings to be mounted one on top of another.

OPERATION

The design of the BATRA ring gives the following basic characteristics :

- Behaviour identical to that of a metallic spring plus damper.
- Robustness :
 - well behaved under shock.
 - removal of the risks of suspension collapse.
- Flexibility easily tailored by stacking BATRA rings.
- Transverse creep limited by the two bonded armatures.

APPLICATIONS

BATRA rings may be used :

- For making suspensions that are very flexible vertically and also damped by the natural properties of the rubber (road and rail vehicles).
- For making very effective anti-shock buffers (wagons, cars, gantries).

For special applications, where the quantities would justify custom manufacture, it is possible to supply Special BATRA rings either with only one bonded lower armature or "all rubber".

For special cases of shock, there are Special BATRA rings with overlapping, non-bonded, armatures.

(1) Natural frequencies with max/min loads, see : OPERATING CHARACTERISTICS.

DIMENSIONS

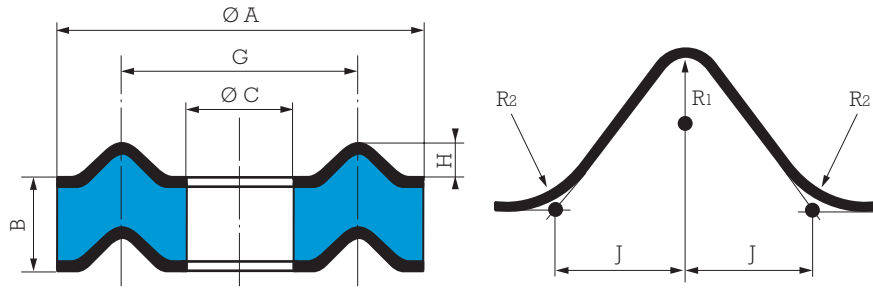

Reference	Ø A mm	B mm	Ø C mm	G mm	H mm	J mm	R ₁ mm	R ₂ mm	Weight g
541050	50	11	14	32	4	5	2.5	1.5	45
541083	80	27	41.5	61	4	6	3	3	220
541082	86	27.5	32	65	5	7	4	2	300
541100	100	28.5	32	65	5	7	4	2	415
541112	115	30	50	85	10	10	5	3	540
541145	140	35	55	100.5	10	10	5	3	890
541146	146	20	55	100.5	10	10	5	3	750
541144	146	35	55	100.5	10	10	5	3	980
541175	170	35	60	115	10	10	5	3	1360
541174	170	50	60	115	10	10	5	3	1680
541185	185	40	95	140	10	10	5	3	1510
541249	250	50	70	160	10	10	5	3	2600
541250	250	59	70	160	10	10	5	3	4400

See current price list for availability of items.

OPERATING CHARACTERISTICS

Static compression		Dynamic compression			Reference
Nominal load daN	Deflection mm	Load daN	Deflect mm (1)	Ø A maxi	
50-200	0.8	600	3.5	57	541050
90-360	3	1100	7	90	541083
125-500	3	1500	7	100	541082
175-700	3	2100	7	115	541100
210-850	3	2500	7	130	541112
325-1300	3.5	4000	9.5	150	541145
375-1500	3	4500	7	158	541144

Static compression		Dynamic compression			Reference
Nominal load daN	Deflection mm	Load daN	Deflect mm (1)	Ø A maxi	
475-1900	1.1	5700	2.5	158	541146
500-2000	3	6000	9.5	190	541175
500-2000	5.3	6000	14	190	541174
500-2000	4.5	6000	12	205	541185
1125-4500	4.5	13500	12	282	541249
1125-4500	5.5	13500	13	282	541250

(1) The instantaneous deflection indicated in this table is approximate as it depends on the impact speed.
It is possible to use a metallic cushion for this application.

1 kg ≈ 1 daN

ASSEMBLY

The rings are centred using the grooves and ridges. To avoid play under no-load conditions, the stack should be pre-compressed by 3 to 10% of its height. It is also necessary to leave sufficient room around the stack for the sideways expansion under load.

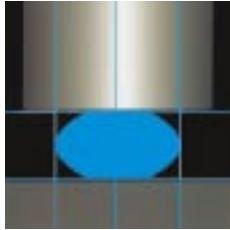

BECA



(1) Natural frequency :
8 to 14 Hz

DESCRIPTION

The BECA mounting comprises one piece elastomer bonded to a top and bottom plate.

- Top plate: smooth or threaded (welded nut) hole.
- Bottom plate: Fixing lugs or direct bearing on the ground.
- Bonded rubber.
- Domed rubber ring.
- Anti-slip bead or grooved anti-slip sole.
- Removable protective top cover : protects the rubber and distributes the load.

OPERATION

The design of the BECA mounting gives the following basic characteristics :

- Transverse elasticity approximately the same as the axial elasticity (equi-frequency).
- Rubber works in compression.
- Progressive buffer against shocks or accidental overload.
- Anti-slip (may be placed directly on the ground).

Advantages :

- The machine may be placed (with its mountings) directly on the ground.
- Very slim.
- Speed of fixing.
- Simple removal of the assembly.
- Extensive range: 3 hardnesses of rubber for 6 existing sizes, allowing the mounting to be optimised as a function of the load and stimulation frequency.
- A choice of 3 fixing styles.

Recommendations :

- In order not to affect the suspension of the machine, all external connections must be flexible.
- BECA mountings can be used for fixed, well-balanced rotating machinery, otherwise a ballasting slab should be used.

(1) Natural frequencies with max/min loads, see : OPERATING CHARACTERISTICS.

Nota : BECA mountings can be replaced by PAULSTRADYN mountings.

DIMENSIONS

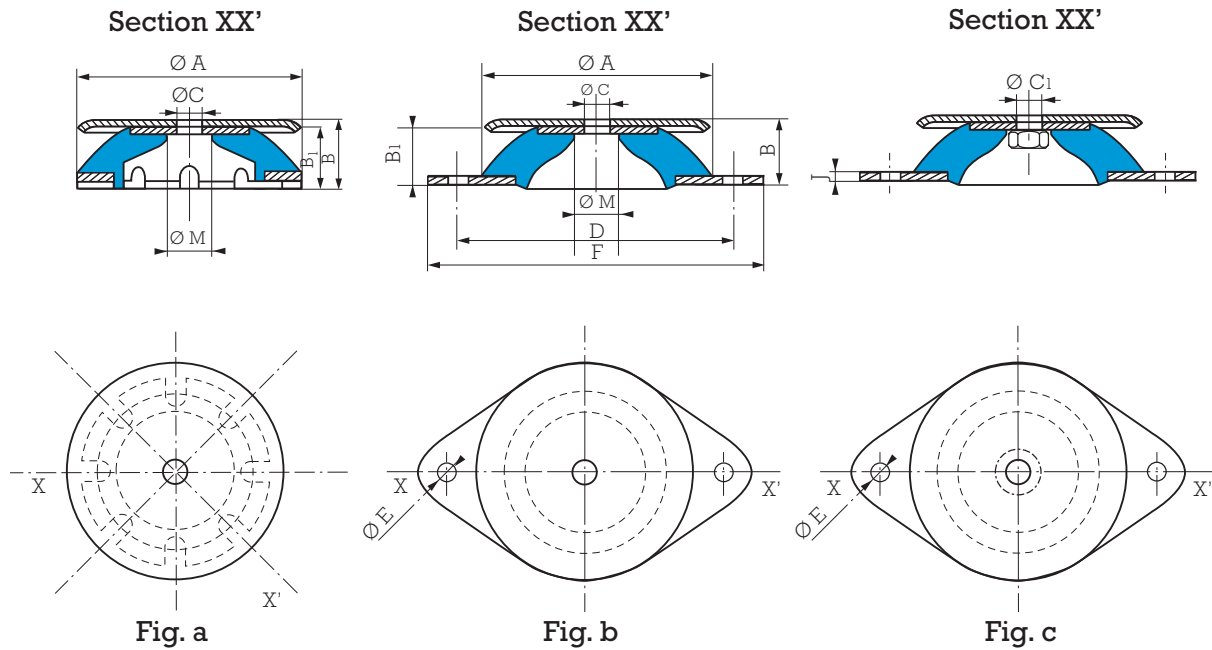

BECA with anti-slip base

BECA with lugs, smooth hole

BECA with lugs, threaded hole

Type	Hardness	Reference			Ø A mm	B mm	B ₁ mm	Ø C mm	Ø C ₁ mm	D mm	Ø E mm	F mm	J mm	Ø M mm	Weight g
		Anti-slip base	Diamond base												
		Smooth hole (fig. a)	Smooth hole (fig. b)	Threaded hole (fig. c)											
Ø 40	45.60	--	--	533641*	40	20	18	-	M6	52	6.2	64	2	19	50
Ø 60	45.60.75	--	--	533661	60	24	22.5	-	M6	76	6.2	90	2	18	140
Ø 80	45.60.75	--	533581	533681	80	27	25	8.1	M8	100	8.2	120	2	22	250
Ø 100	45.60.75	533108	--	--	100	30	28	10.2	-	-	-	-	-	22	420
Ø 100	45.60.75	--	533109	533609	100	27.5	25.5	10.2	M10	124	10.2	148	2.5	22	460
Ø 150	45.60.75	533151	--	--	150	41	38	14.2	-	-	-	-	-	34	1220
Ø 150	45.60.75	--	533152	533652	150	39	36	14.2	M14	182	12.2	214	4	34	1340
Ø 200	45.60.75	533202	--	--	200	46	42	18	-	-	-	-	-	44	2750
Ø 200	45.60.75	--	533203	533623	200	44	40	18	M18	240	14.5	280	5	44	3030

* Ø 40, M6 - RAPID nut - max. torque 3 N.m.

See current price list for availability of items.

OPERATING CHARACTERISTICS

Nominal static load daN	Deflection mm	Type	Hardness
1-4	2	Ø 40	45
2-10	2.5	Ø 40	60
3-15	3	Ø 60	45
6-25	3	Ø 60	60
11-45	3	Ø 60	75
11-45	4.5	Ø 80	45
20-80	4.5	Ø 80	60
22-90	4	Ø 100	45
30-120	4	Ø 80	75

Nominal static load daN	Deflection mm	Type	Hardness
30-130	7	Ø 150	45
40-160	4	Ø 100	60
50-220	4	Ø 100	75
60-250	7	Ø 150	60
85-350	6	Ø 150	75
125-500	7	Ø 200	45
200-825	7	Ø 200	60
310-1250	6	Ø 200	75

1 kg ≈ 1 daN

LOAD/DEFLECTION CURVES IN AXIAL COMPRESSION

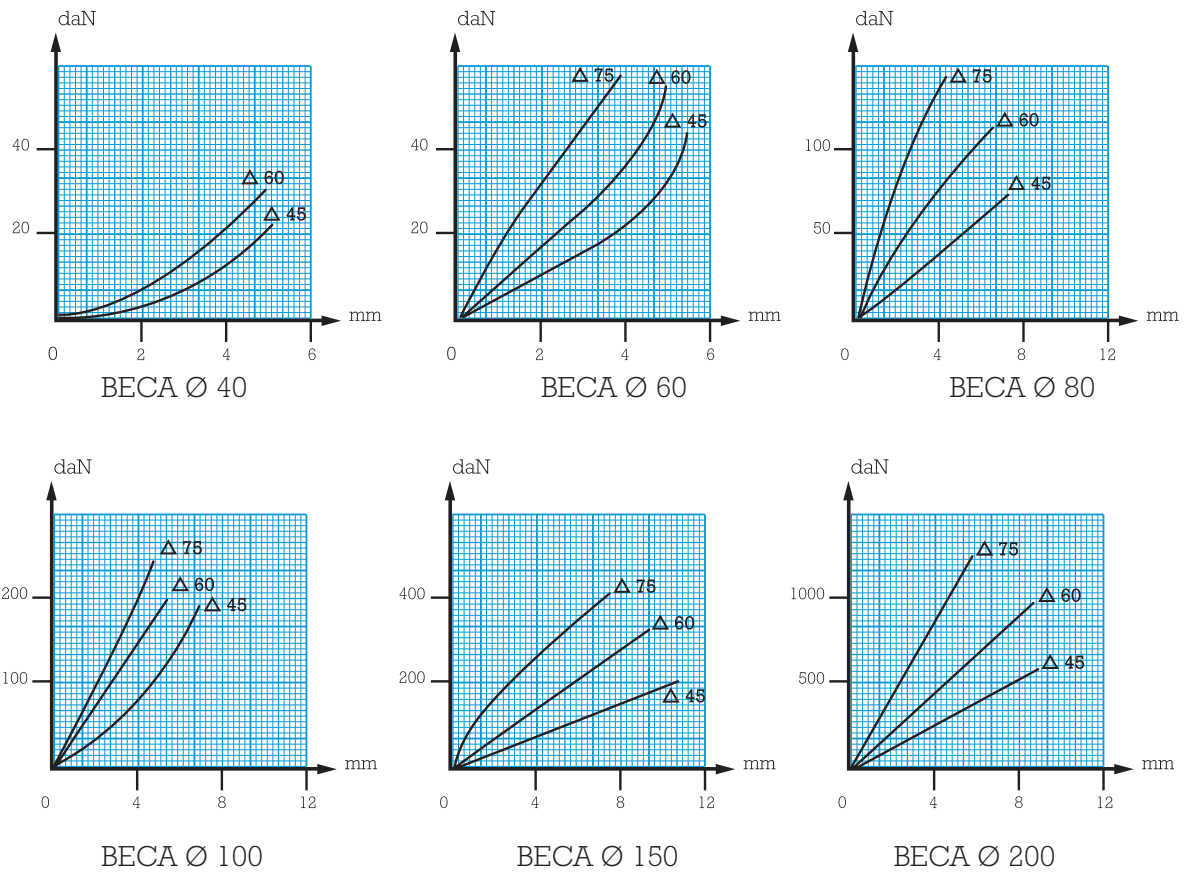

ASSEMBLY

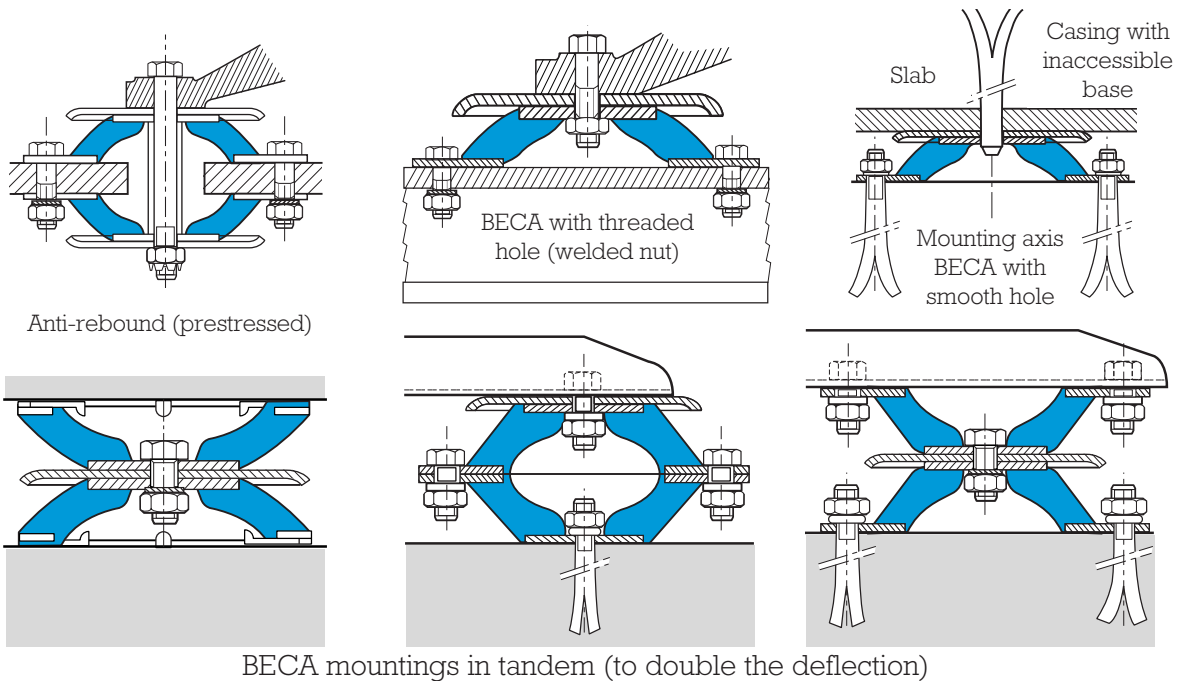

All our mountings are identified by conventional markings, either a paint spot or figures indicating the hardness : grey = hardness 45, green = hardness 60, blue = hardness 75.

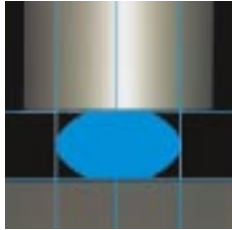

POLYFLEX

(1) Natural frequency : 9 to 20 Hz

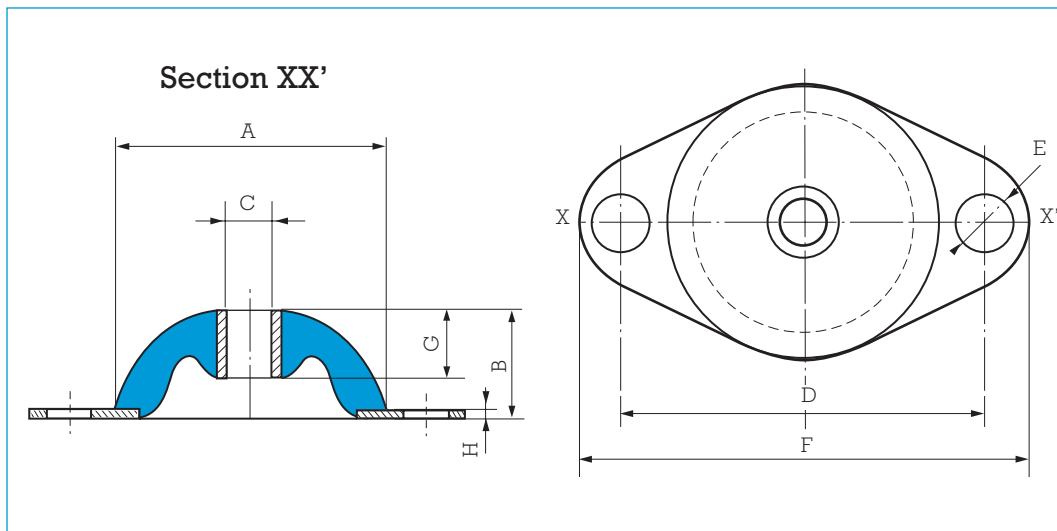

DIMENSIONS

Reference	Ø A mm	B mm	Ø C mm	D mm	Ø E mm	F mm	G mm	H mm
532300	30	16	6	40	6.1	50	8	1.5
532500	50	20	8	66	8.2	82	13	2
532563	55	23	10.1	90	8.2	106	15	3
532561	60	25	12.2	76	8.5	95	20	4
532750	75	30	12.2	95	11.0	118	25	6

See current price list for availability of items.

OPERATING CHARACTERISTICS

Nominal static load daN	Deflection mm	Reference	Hardness
1-5	3	532300	45
1-7	2	532300	60
2-8	1	532300	75
2-10	4	532500	45
3-15	3	532500	60
4-18	5	532563	45
5-20	2.5	532500	75
7-30	3	532561	45

Nominal static load daN	Deflection mm	Reference	Hardness
7-30	5	532563	60
10-40	2	532561	60
10-50	1.5	532561	75
10-50	4	532750	45
15-60	5.5	532563	75
15-65	3	532750	60
20-80	1.5	532750	75

(1) Natural frequencies with max/min loads, see : OPERATING CHARACTERISTICS.

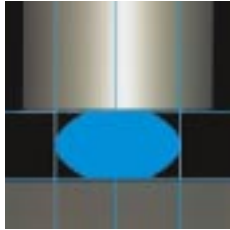

S.C.P. MOUNTING

(1) Natural frequency : 9 to 15 Hz

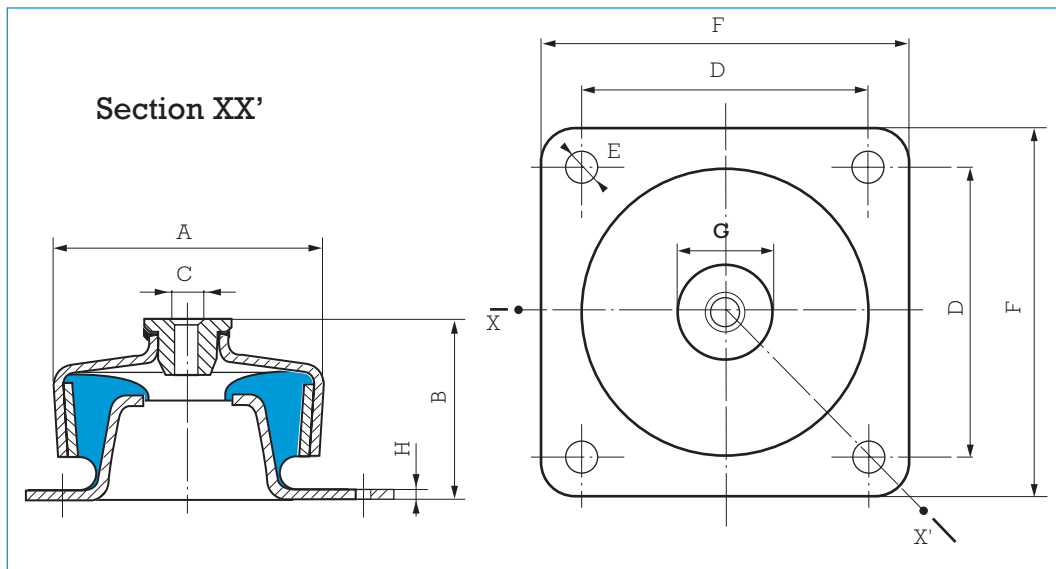

DIMENSIONS

Reference	Ø A mm	B mm	Ø C mm	D mm	Ø E mm	F mm	G mm	H mm
530120	74	53	10	72	9	90	32	3
530220	92	63	12	90	11	114	36	3
530420	124	94	16	114	13	144	60	4

OPERATING CHARACTERISTICS

Reference	HARDNESS 45		HARDNESS 60		HARDNESS 75		Weight g
	Load daN	Deflect. mm	Load daN	Deflect. mm	Load daN	Deflect. mm	
530120	70	3	120	2.5	175	2	580
530220	140	4	200	3	300	2.5	1000
530420	300	5	500	5	800	4	2550

See current price list for availability of items.

(1) Natural frequencies with max/min loads, see : OPERATING CHARACTERISTICS.

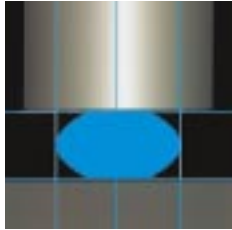

ISO FLEX

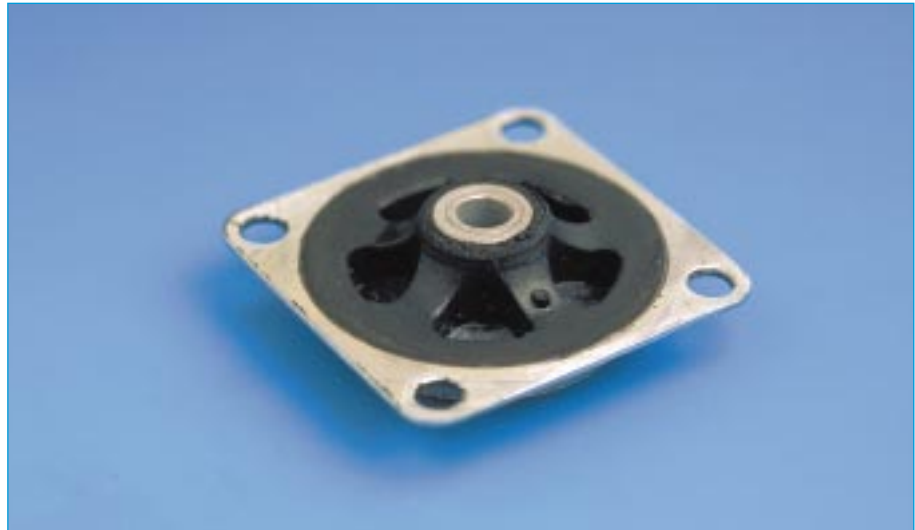

(1) Natural frequency :
11 to 15 Hz

DESCRIPTION

The ISO FLEX mounting comprises two concentric metallic parts joined by a bonded, perforated rubber ring.

OPERATION

The design of the ISO FLEX mounting gives the following basic characteristics :

- Elasticity approximately the same in all directions (equi-frequent mounting).

APPLICATIONS

ISO FLEX mountings may be used for suspending any small measuring or recording equipment, mobile equipment, machine tool controls.

(1) Natural frequencies with max/min loads, see : OPERATING CHARACTERISTICS.

DIMENSIONS

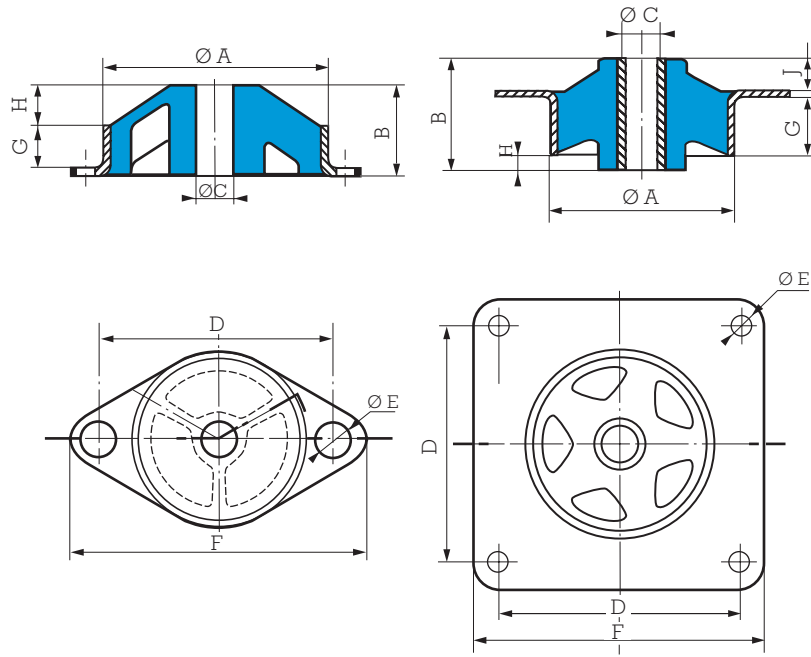

Fig. a

Fig. b

Type	Fig.	Reference	Hard.	Ø A mm	B mm	Ø C mm	D mm	Ø E mm	F mm	G mm	H mm	J mm	Weight g
R	a	552428	50	28	8	4.2	36	3.2	44	4	3	-	9
I.20	b	552231	45-60	25.4	10.3	4.2	25.4	3.6	31.8	4.2	1	4.3	10
I.30	b	552241	45-60	38.1	15.9	6.2	34.9	4.2	44.5	7.3	-	7.3	30

See current price list for availability of items.

OPERATING CHARACTERISTICS

Nominal static load daN	Deflection mm	Type	Reference	Hard.	Nominal static load daN	Deflection mm	Type	Reference	Hard.
0.25-1	3	R	552428	50	1-4	3	I.30	552241	45
0.50-2	3	I.20	552231	45	1.5-6	2	I.30	552241	60
0.75-3	2.5	I.20	552231	60					

All our mountings are identified by conventional markings, either a paint spot or figures indicating the hardness:

grey = hardness 45, green = hardness 60, blue = hardness 75.

ASSEMBLY

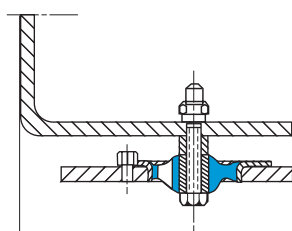

Fixing method

To avoid toppling or canting, the suspension should be designed so that the centre of gravity of the suspended equipment is close to the geometrical centre of the suspension.

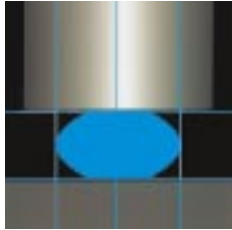

ISODYNE



DESCRIPTION

The ISODYNE mounting comprises two half mountings joined together.

OPERATION

The design of the ISODYNE mounting gives the following basic characteristics :

- A very high axial to radial stiffness ratio.
- Vertical fixing avoiding excessive inclination of the equipment.
- Fixing at any angle.
- Safe, anti-rebound.

APPLICATIONS

ISODYNE can be used to suspend lightweight equipment in a vertical plane.

DIMENSIONS

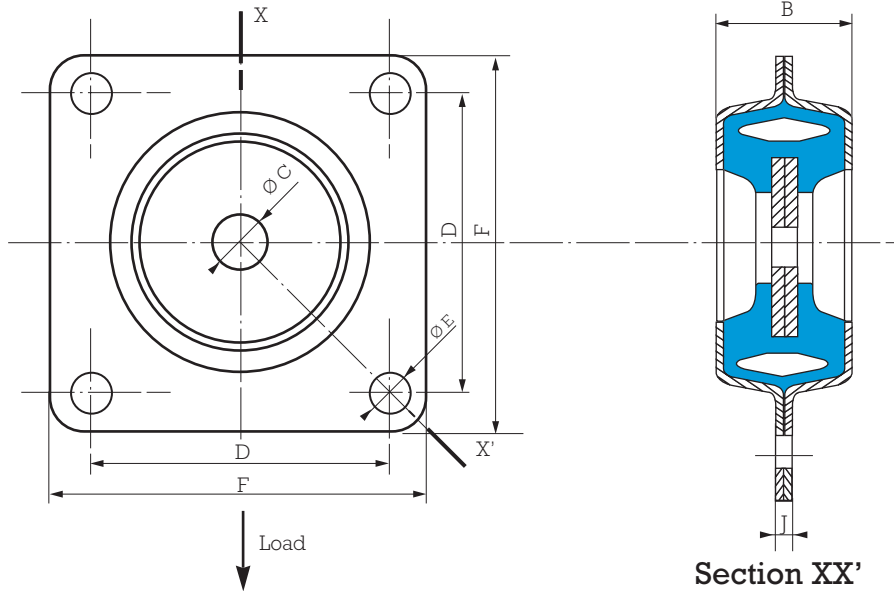

Reference	Hardness	B mm	Ø C mm	D mm	Ø E mm	F mm	J mm	Weight g
551321	50	16	4.2	25.4	3.5	32	1.6	10
551441	45	18	6.5	35	4.2	44.5	2	24
551571	45.60	20	8.2	45.5	6.2	57.5	2	50

See current price list for availability of items.

OPERATING CHARACTERISTICS

Nominal static load daN	Deflect. mm	Reference	Hard.
2.5	1	551321	50
10	3	551441	45

Nominal static load daN	Deflect. mm	Reference	Hard.
25	2.5	551571	45
35	2.5	551571	60

ASSEMBLY

Fixing clearances (approximate)

Reference	G mm	H mm
551321	28	18
551441	40	20
551571	47	22

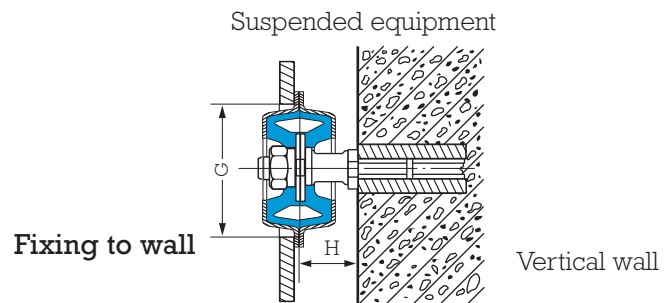

Fixing a control panel against a wall or vertical frame.

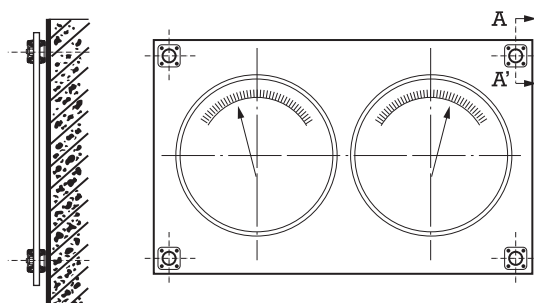

Fixing to frame

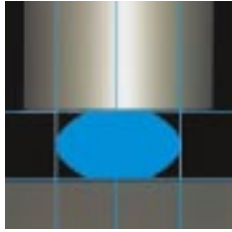

S.L.F. MOUNTS



New !

Natural frequency :
10 to 25 Hz

SILICONE RUBBER / SPECIAL ELECTRONICS

SMALL LOADS / HIGH DEFLECTIONS

DESCRIPTION

Low frequency high deflection antivibration mounting available in a choice of elastomers including high damped silicone. The zinc plated mild steel metalwork is fully bonded for improved fatigue strength.

APPLICATIONS

These mounts have been designed to protect low mass components and instruments from vibration and shock and to isolate small rotating machines e.g. pumps and electric motors.

DIMENSIONS

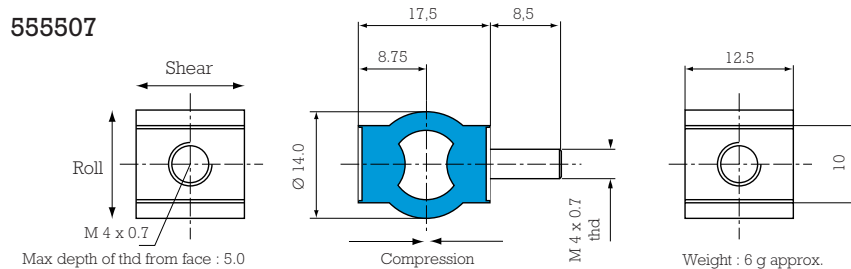

OPERATING CHARACTERISTICS

Maximum sinusoidal input at resonance : ± 0.5 mm.
 Resonance frequencies at maximum input : 10 to 25 Hz dependent on axis and load.
 Axial to radial stiffness : 3 : 1.
 Amplification at resonance : silicone mounting : 4 rubber mounting : 10.
 Maximum displacement during shock : axial : 5 mm.
 radial : 7 mm.

Mechanical strength corresponding to a continuous acceleration of 10 g at maximum load.

Part number	Mix	Static load in compression kg	Static load in shear kg	Static load in roll kg	Temperature for continuous operation
55500*42	Silicone 42 Sh	0.10 - 0.50	0.10 - 0.25	0.10 - 0.15	- 54 to + 150°C
55500*72	Silicone 70 Sh	0.60 - 0.80	0.25 - 0.50	0.15 - 0.30	
55500*01	NR 50 Sh	0.10 - 1.50	0.10 - 0.50	0.10 - 0.40	- 40 to + 70°C
55500*02	NR 70 SH	1.50 - 3.00	0.50 - 1.00	0.40 - 0.80	

NB : The * define the type of fixing : combination fixing : 555507 male/male fixing : 555505 female/female fixing : 555506

ASSEMBLY

Improved stability can be achieved if the mounts are inclined at 45° towards the centre of gravity.



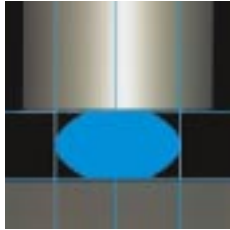

“SANDWICH” MOUNTING



(1) Natural frequency :
5 to 13 Hz

DESCRIPTION

The SANDWICH mounting comprises one or more layers of elastomer bonded to flat, parallel metallic plates. These mountings may be cylindrical or rectangular. They are designed to withstand very high compressive loads. The range of mechanical characteristics is governed by the hardness of the rubber and the number of intermediate metallic plates.

These mountings can support compression from 20 to 100 bars.

The metal plates usually receive a phosphate anti-corrosion treatment.

The elastomer is polychloroprene which provides a high resistance to atmospheric exposure.

OPERATION

The design of the SANDWICH mounting gives the following basic characteristics :

- Very slim.
- Large surface area.
- Stackable mountings.
- The suspended equipment is free to move in all directions.
- High ratio of axial stiffness to radial stiffness.
- Very high axial loads.

(1) Natural frequencies with max/min loads, see : OPERATING CHARACTERISTICS.

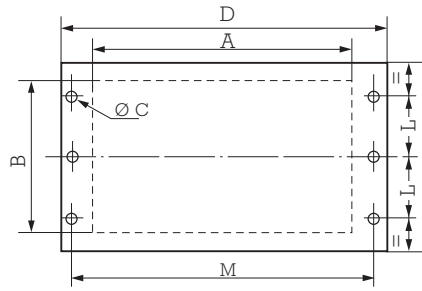

Fig. A

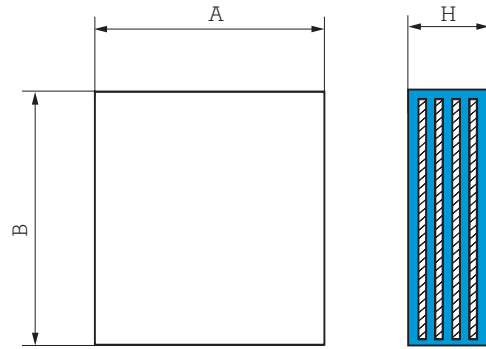
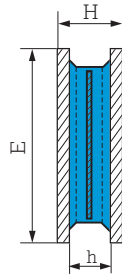

Fig. B

MOUNTINGS WITH FIXING PLATES Fig. A

Reference without intermediate plate	Reference with intermediate plate	A mm	B mm	D mm	E mm	H mm	h mm	N° holes x Ø C (mm)	L mm	M mm	Weight kg
539608	539607	182	142	255	170	49	40	6 x 9	58	235	5
539612	539933	372	252	460	300	61	50	6 x 13	100	430	18
539613		702	252	805	300	61	50	6 x 17	95	765	35
	539267	160	110	230	110	58	44	4 x 15	35	202	5
539821		283	140	380	140	76	60	6 x 18	50	340	9.5

See current price list for availability of items.

Nominal static load	Deflection mm	Reference	Hard.
1000-4000	12	539821	50
1250-5000	7	539608	60
2500-10000	6	539607	45
6250-25000	3.5	539267	70
3750-15000	5	539607	60

Nominal static load	Deflection mm	Reference	Hard.
5000-20000	6	539612	45
7500-30000	7	539612	60
11250-45000	5	539613	60
15000-60000	4	539933	60

MOUNTINGS WITHOUT FIXING PLATES Fig. B

Reference	A (=D) mm	B (=E) mm	H mm	Maximum static load daN
539832	200	165	38	95 000
539823	220	220	270	150 000
539833	240	200	38	145 000
539992	250	250	140	200 000
539820	400	300	78	380 000
539835	405	255	61	310 000
539537	500	500	66.5	870 000
539890	510	410	82	700 000
539939	600	500	125	1 000 000
539520	650	650	152	1 500 000
539924	702	252	52	450 000
539903	800	250	190	480 000
539701	750	750	300	2 000 000
519821	200	190	60	115 000
519822	260	230	60	185 000
519823	280	180	60	143 000

CYLINDRICAL MOUNTINGS

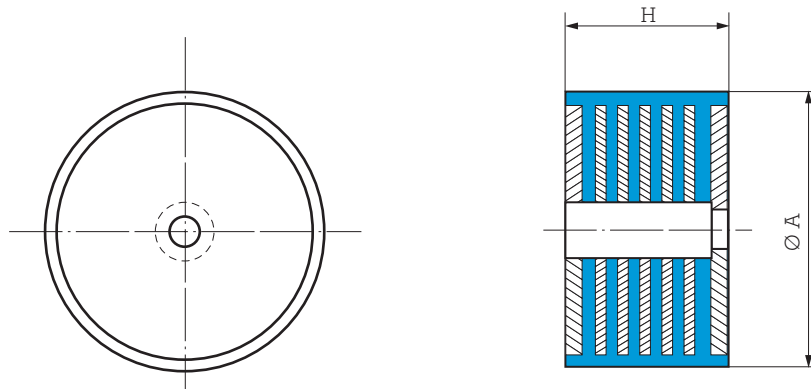

Reference	A mm	H mm	Nominal static load daN
539904	115	54	1 500
544051	150	110	12 000
539796	200	96.5	18 000
539983	200	90	5 000
539539	275	275	5 000
539938	320	19	100 000
539937	350	105	110 000
539900	400	117	150 000
544078	600	167	300 000
544079	600	285	433 000
544080	860	300	650 000

Various types of fixing are available. Consult us for information.

DOMINANTLY RADIAL MOUNTINGS

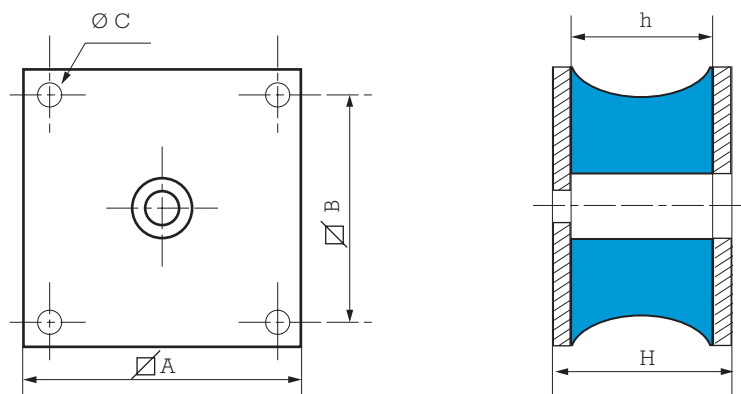

Reference	$\varnothing A$ mm	h mm	$\varnothing B$ mm	H mm	$\varnothing C$ mm	Shear		Compression daN
						mm	daN	
534646	150	62	120	70	12,5	20	200	1 500
534647	150	62	120	70	12,5	20	150	1 000
534455	232	74	190	86	16,5	25	500	2 000
534456	232	74	190	86	16,5	25	625	3 500
539898*	180	88	146	100	13	10	400	3 000
539917*	180	66	146	76	13	10	250	1 500
539940	300 x 480	318	430 x 219	350	18	70	4500	13 000
539806	360 x 200	100	330 x 170	120	18	30	1200	3 000
544051*	240 x 160	100	190 x 110	110	17	50	1800	10 000

* Multilayer laminated part.

Various types of fixing are available. Consult us for information.



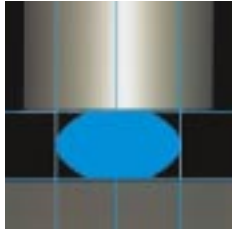

ELIGO

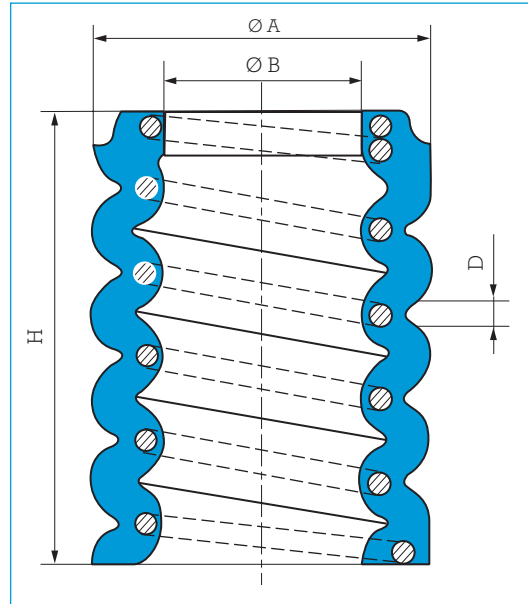

Reference	Ø A mm	Ø B mm	D mm	H unloaded mm	Nominal static load daN	Deflection mm
537070	70	28	4	148	300	41
537007	70	28	4	175	300	61
537001	70	28	4	200	180	62
537000	92	61	7	87	350	20
537137	140	74	14	157	1500	30
537115	155	80	10	250	1000	62
537117	155	80	10	340	1000	91
537119	212	118	12	149	2500	40
537120	212	118	12	284	2500	78
537144	260	119	18	400	6650	143
537116	283	148	20	380	5500	150
537114	283	148	20	450	6000	180

See current price list for availability of items.

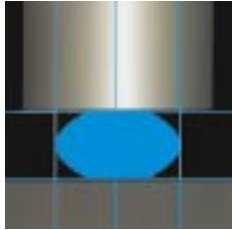

SUPPORTS AND BUMP STOPS

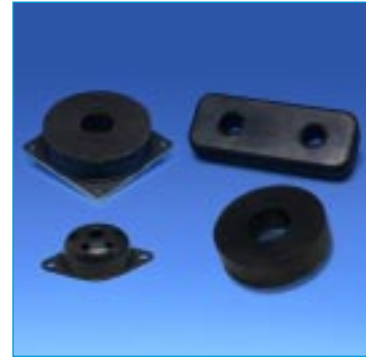

Reference : **514202** - Hardness : 75 - Compressive load : 5000 daN - Deflection : 8 mm

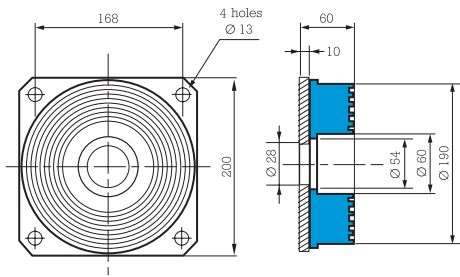

Reference : **534501** - Hardness : 60 - Load : Compression : 2500 daN - Deflection : 15 mm - Shear load : 300 daN - Deflection : 10 mm

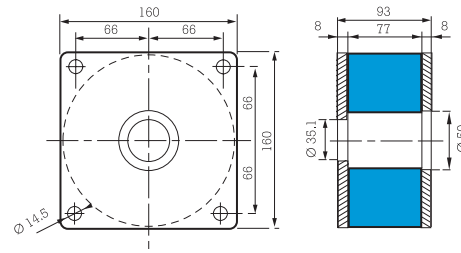

Reference : **813501** - Hardness : 60 - Compressive load : 1000 daN - Deflection : 4 mm

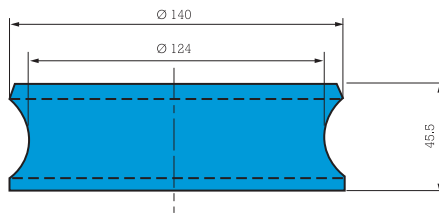

Reference : **817505** - Hardness 60 - Compressive load : 1500 daN - Deflection : 5 mm

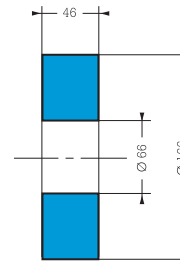

Reference : **813506** - Hardness 60 - Compressive load : 4000 daN - Deflection : 2.4 mm

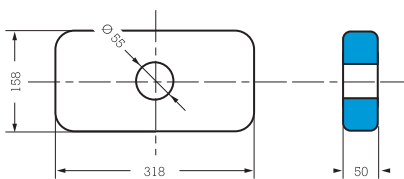

Reference : **817605** - Hardness 60 - Compressive load : 2000 daN - Deflection : 1.4 mm

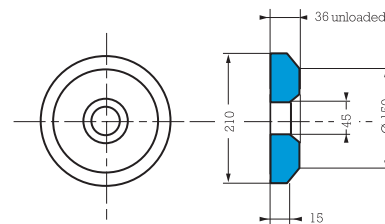

Reference : **813504** - Hardness 60 - Compressive load : 3000 daN - Deflection : 9 mm

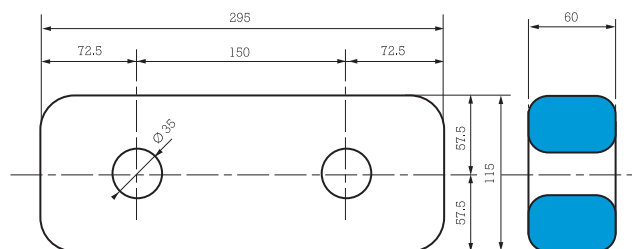

See current price list for availability of items.

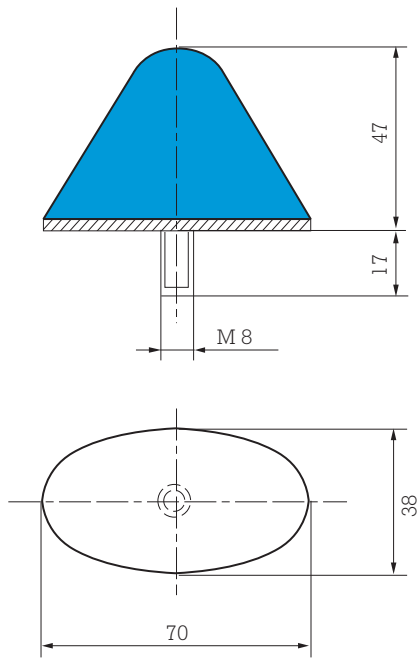

Deflection : 14 mm
 Maximum load : 150 daN
 Reference **512389**

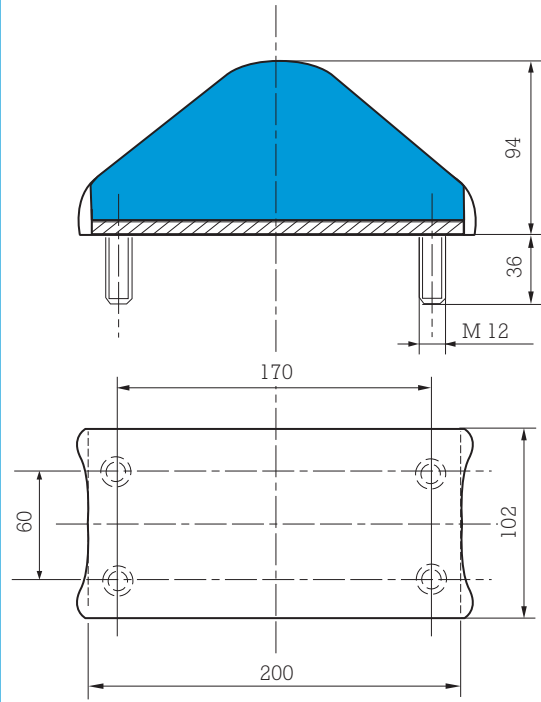

Deflection : 35 mm
 Maximum load : 3 000 daN
 Reference **519186**

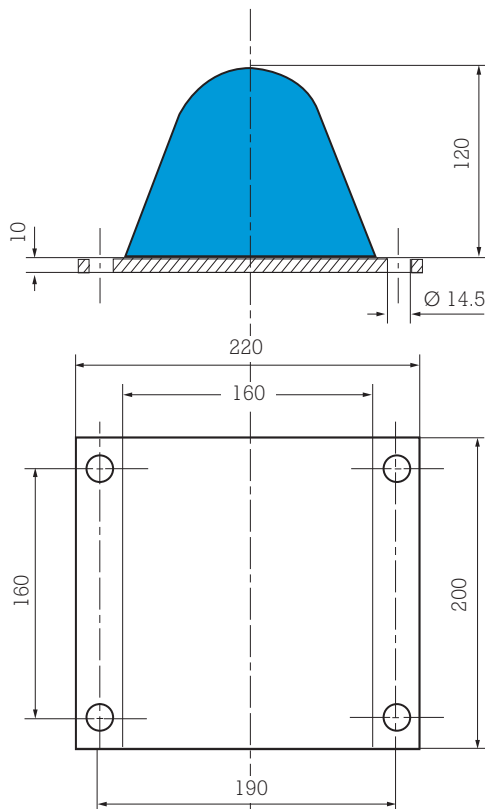

Deflection : 45 mm
 Maximum load : 4 800 daN
 Reference **512991**

See current price list for availability of items.

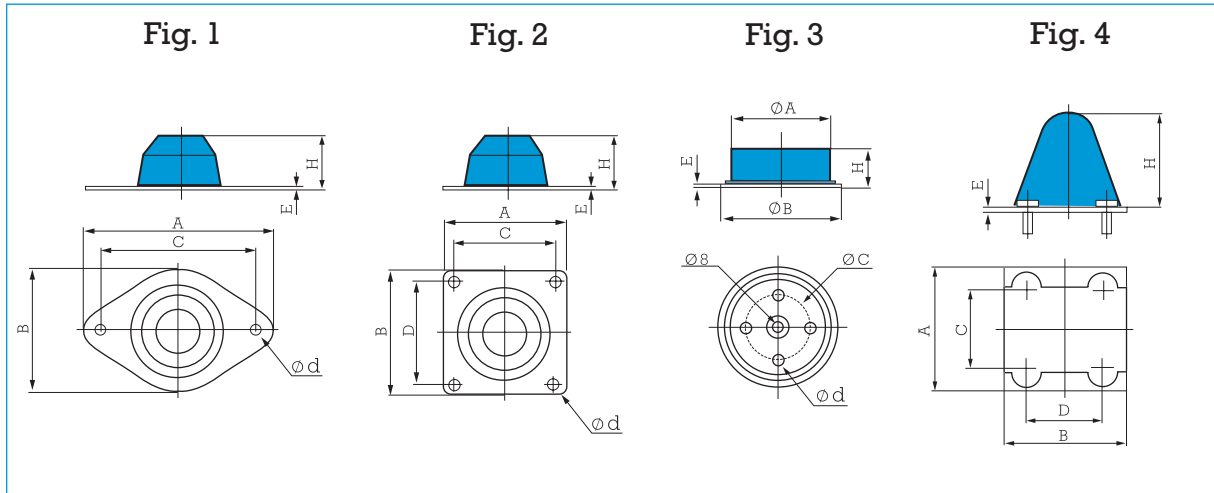

See Paulstra
elastomer range:
Stops

Reference	Fig.	A mm	B mm	C mm	D mm	E mm	H mm	Deflection under load mm	Load maxi KN	Ø d
E1V-3245-04*	4	135	125	106	85	5	110	--	50	M10
E1V-3568-01*	3	126		80		3	36	10	59	5/16 or M8
E1V-3892-01*	2	196	140	174	118	5	85	40	25	13
E1V-3914-01*	1	170	110	140		3	40	25	20	15
E1V-3921-01*	1	170	110	140		3	50	31	28	15
E1V-3922-01*	2	180	180	148	148	6	56	32	60	15
E1V-3927-01*	1	170	110	140		3	40	25	28.5	15
E1V-3931-01*	2	110	110	92	92	3	90	--	26	9
E1V-3932-01*	1	170	110	140		3	30	15.5	50	15
E1V-3940-01*	1	170	88	140		3	20	10	30	15
E1V-4031-01*	1	170	110	140		3	65	41	25	15
E1V-4059-11*	1	234	125	200		5	70	40	51.2	14
519805	1	170	110	140		3	50	31	28	15
519830	2	100	110	80	90	3	62	25	12.5	11

*Vibrachoc range

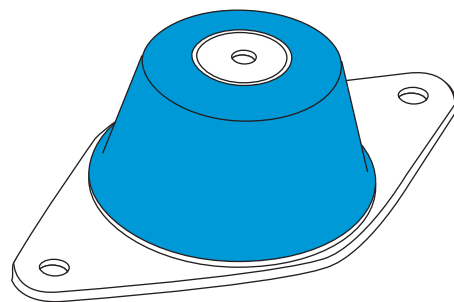
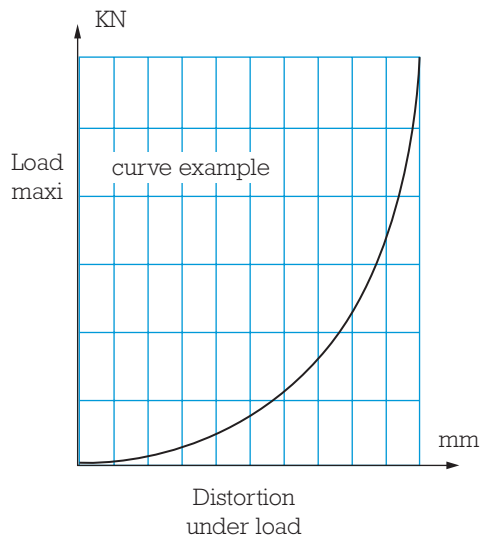

Advantages:
- sliding plate.
- integrated stop.
- progressive stiffness.

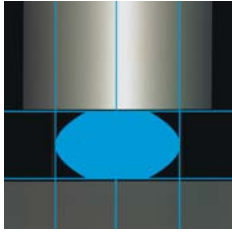

OTHER MOUNTINGS

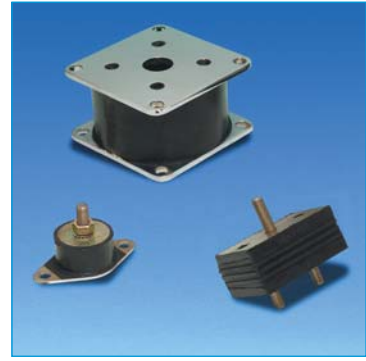

SMALL LOADS VERSATILE MOUNTING

Compression

Compression:
 Deflection: 1.8 mm
 Maximum load: 3 daN

Reference **544172-11**

Reference **539515**

See current price list for availability of items.

1 kg ≈ 1 daN



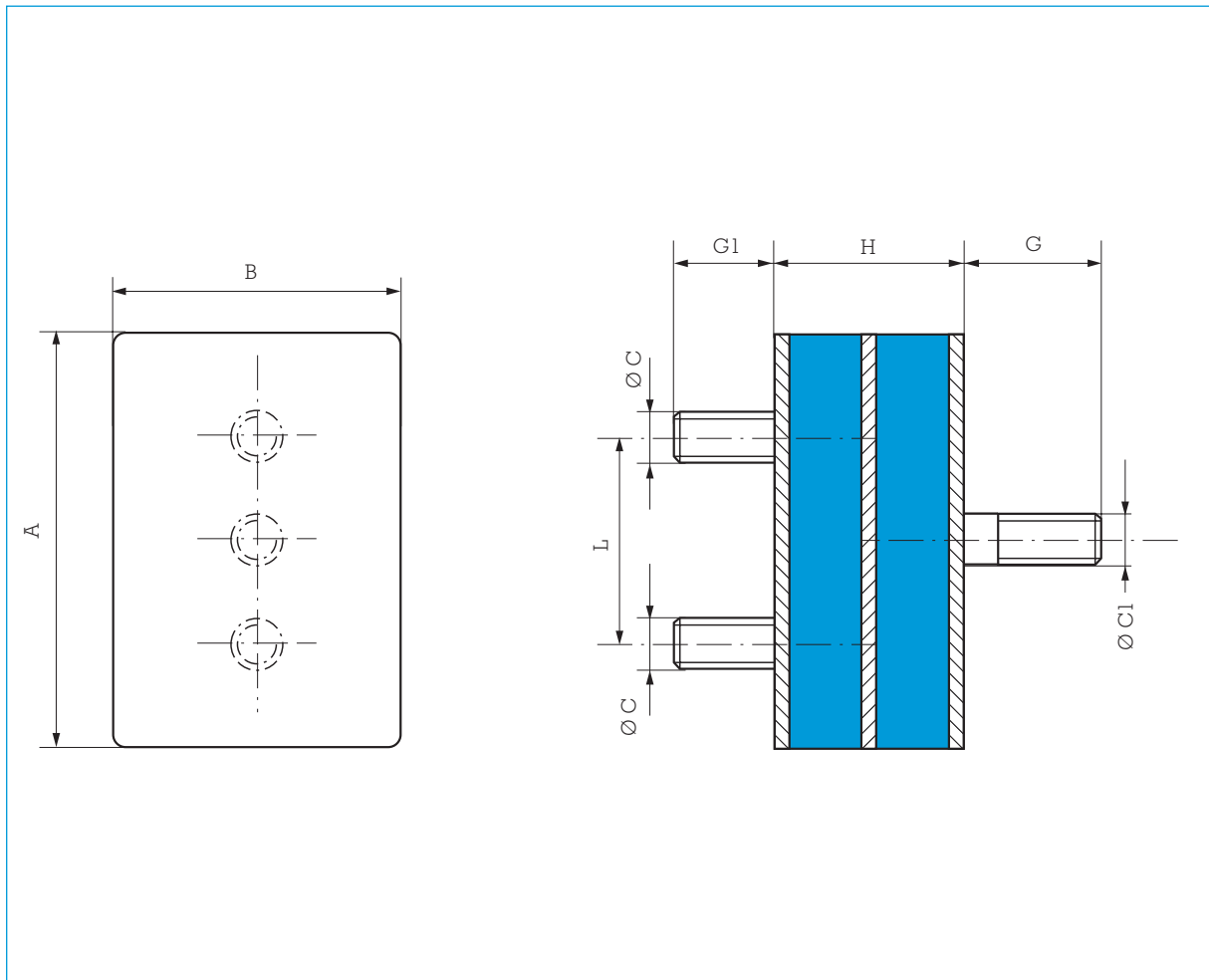

DIMENSIONS

Reference	A mm	B mm	H mm	Ø C	Ø C1	G mm	G1 mm	L mm	Number intermed. plates
538076	100	70	46	M10	M12	34	23	50	-
539214	100	70	46	M10	M12	31	23	50	2
539377*	100	70	46	M10	M12	33	23	50	1

* This reference has 4 screws.

OPERATING CHARACTERISTICS

Reference	Hardness	Static load daN	Deflection mm
538076	45	300	5
539214	40	300	1
539377	60	300	0.7

* This reference has 4 screws.

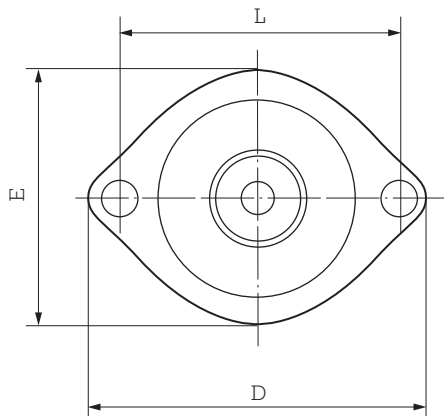
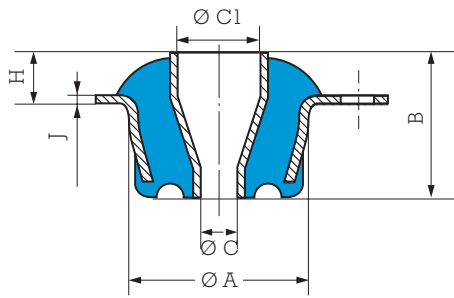

Reference **539004**

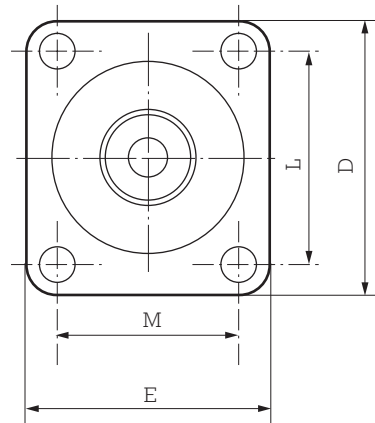
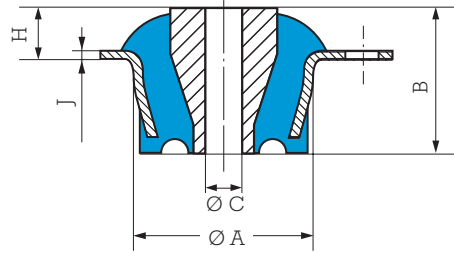

Reference **539743**

DIMENSIONS

Reference	A mm	B mm	Ø C mm	Ø C1 mm	D mm	E mm	H mm	J mm	L mm	M mm
539004	54	40	15.8	25.4	102	76	13.5	3	82.5	-
539743	74	71	16.25		105	92	33.5	3	82.5	69.5

OPERATING CHARACTERISTICS

Reference	Hardness	Axial stiffness	
		Load daN	Deflection mm
539004	50	150	2
	60	230	2
539743	45	200	4.5

1 kg ≈ 1 daN



Fig. 1

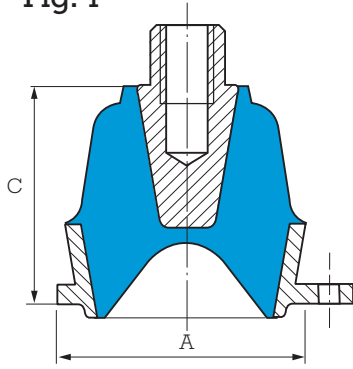

Fig. 2

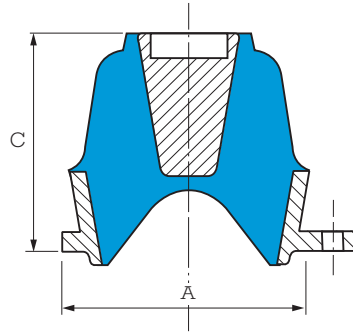
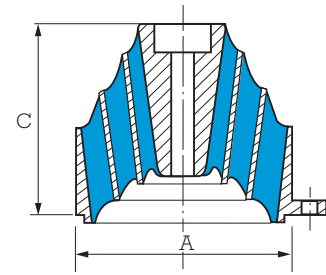
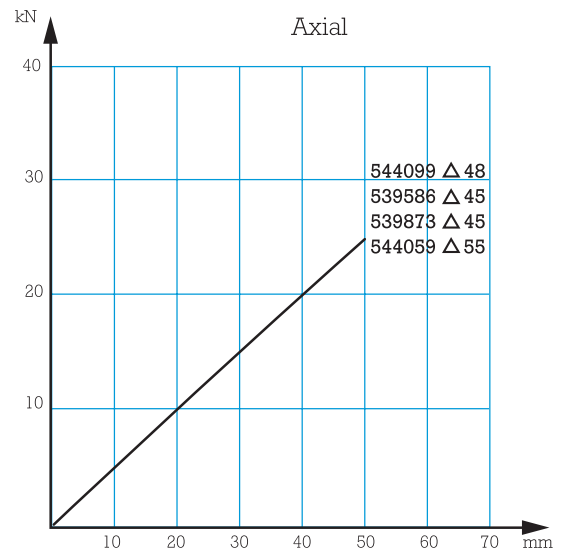
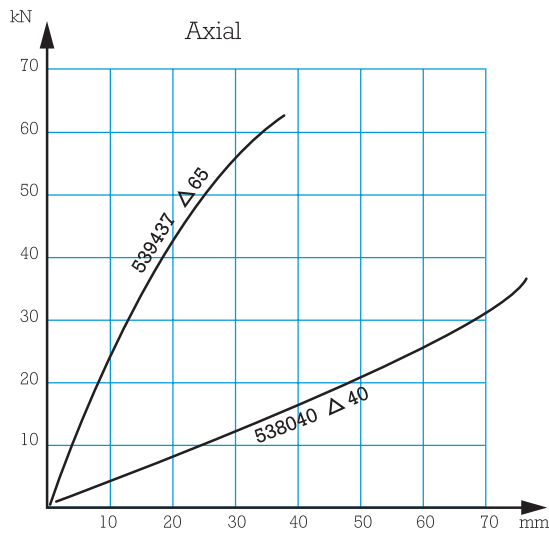
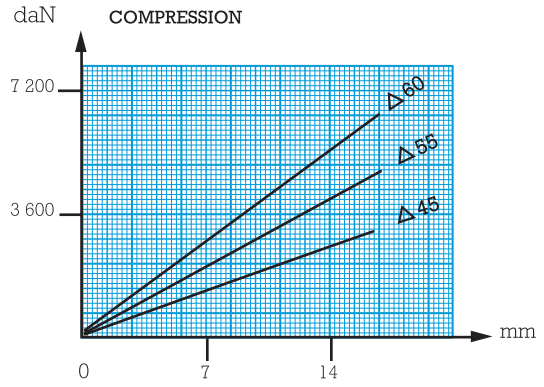
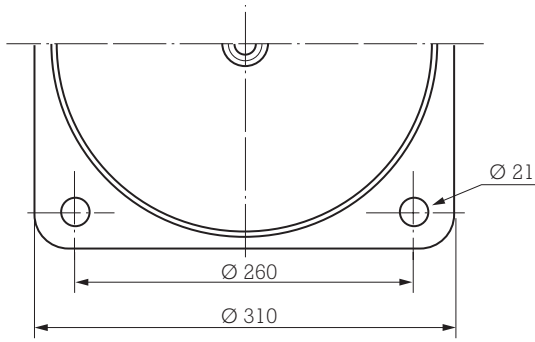
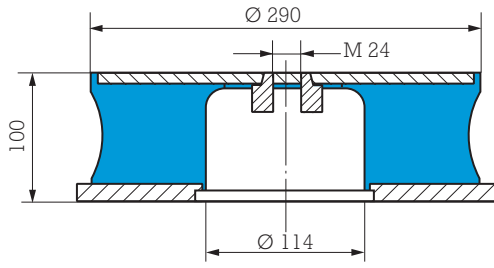

Fig. 3



Reference	A mm	C mm	Load daN	Fig.
544099	180	172	2500	1
539586	190	170	2800	1
539873	190	172	3000	1
544059	190	175	3000	1
538040	280	252	4000	3
539437	350	275	6000	2





Reference **539972**

Also exists with anti-rebound stop - Reference **539971**

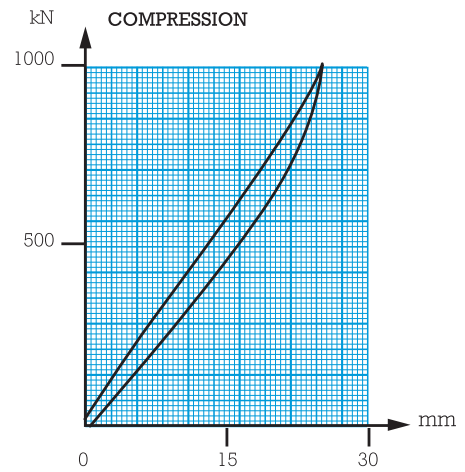
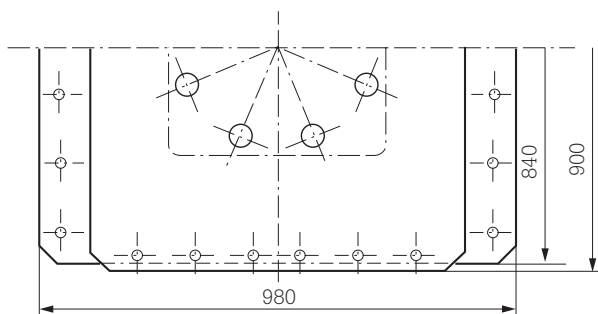
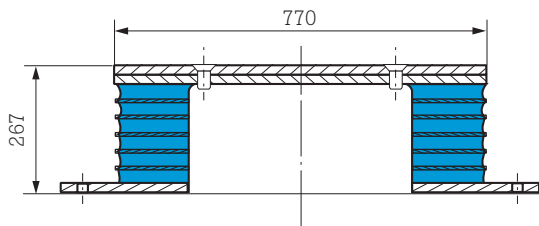

Reference **539925**

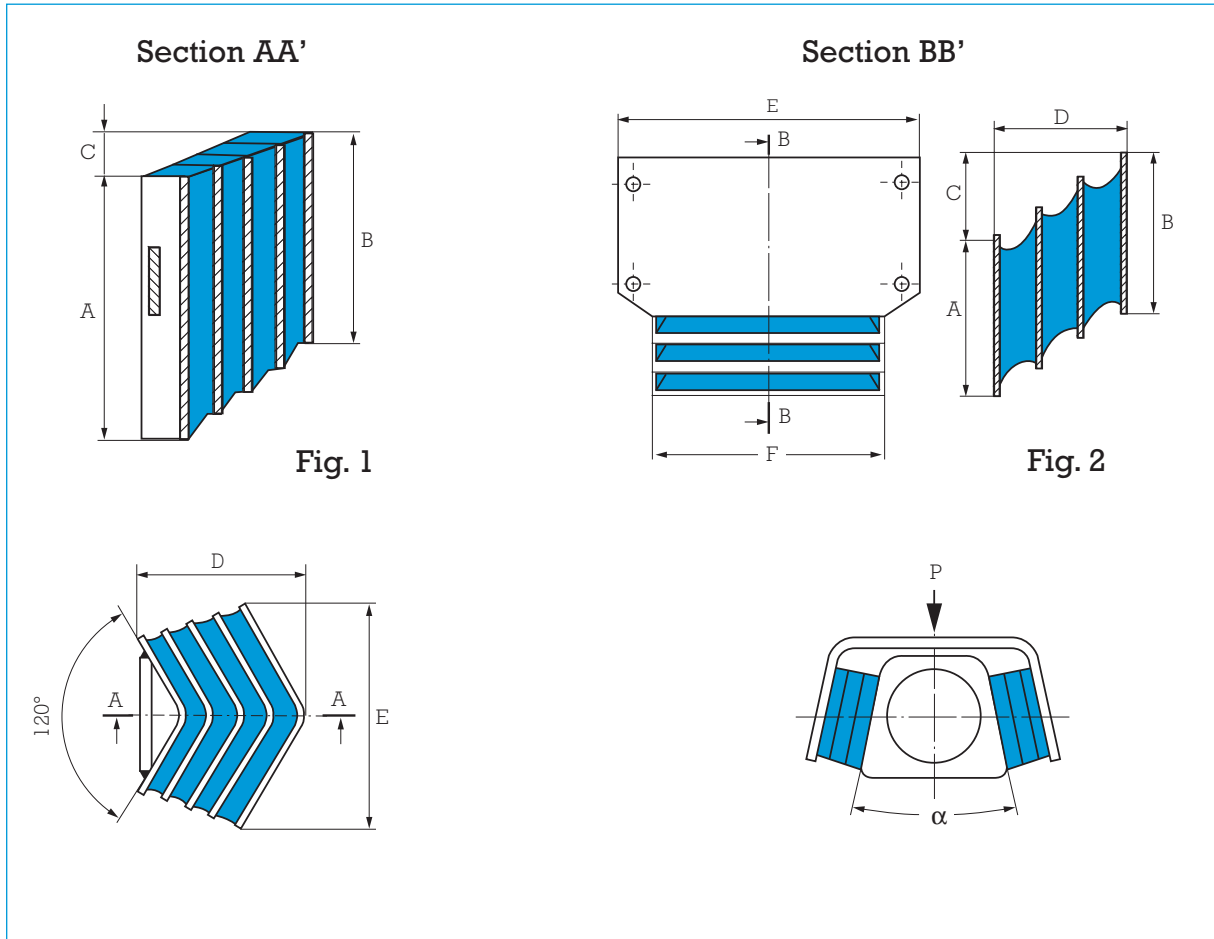

CHEVRON MOUNTINGS

Reference	A mm	B mm	C mm	D mm	E mm	F mm	Load daN	α mm	Fig.	Vertical stiffness daN/mm
544066	246	213	52	154	203	-	7000	22	1	200
539555	250	184.5	60	197	240	-	8000	5	1	120
539376	191.5	178	30	193	123	-	6000	22	1	166
538000	191	141	95	113	203	-	3400	16	1	68
539549	152	160	79	130	300	231	4500	26	2	80
539952	179	179	70	140	197	197	5500	26	2	75

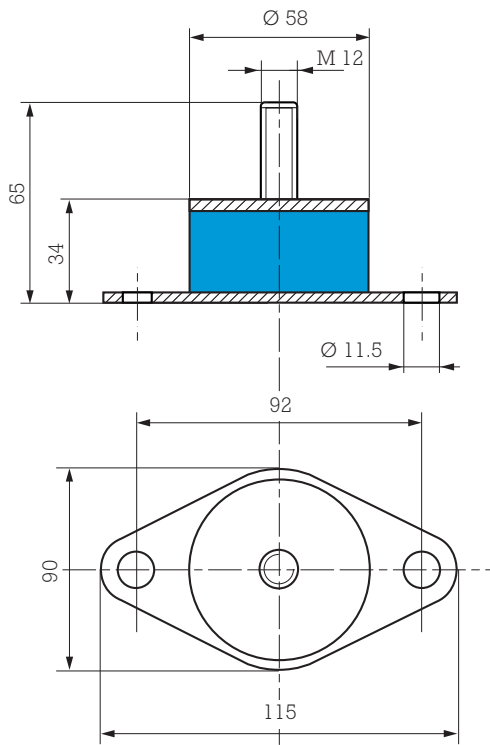

Deflection : 5 mm
 Maximum load : 250 daN
 Reference **539243**

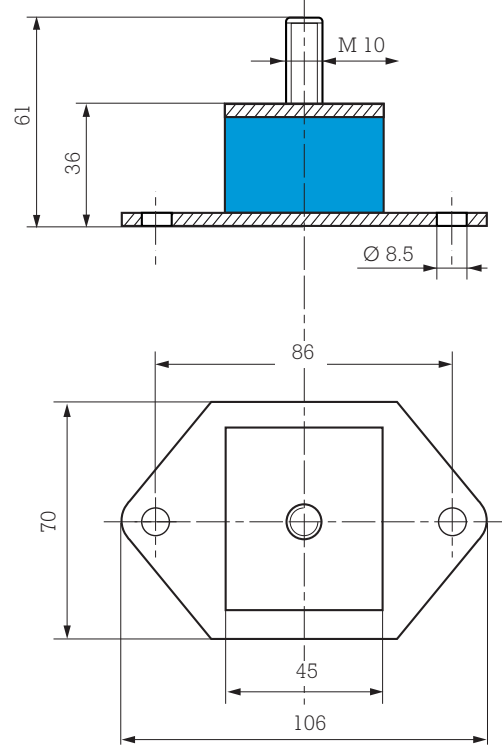

Deflection : 3 mm
 Maximum load : 150 daN
 Reference **534135**

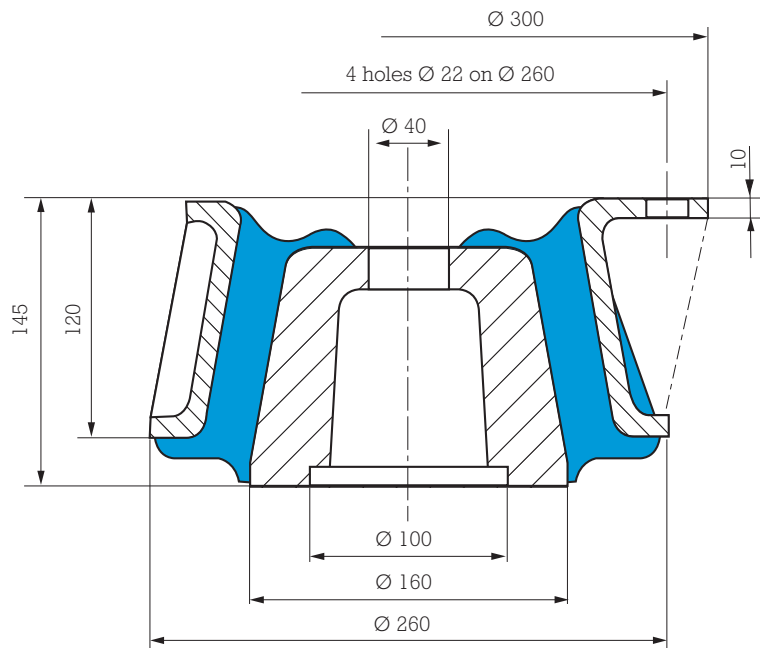

Deflection : 12 mm
 Maximum load : 6 000 daN
 Reference **539024**

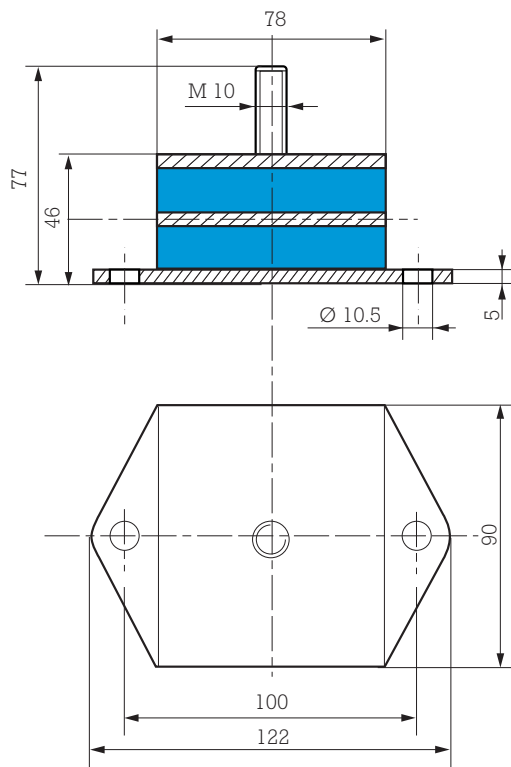

Compression :
 Deflection : 4.5 mm
 Maximum load : 800 daN

Shear :
 Deflection : 6.5 mm
 Maximum load : 80 daN

Reference **534079**

New !

VERY LOW LOADS MOUNTING (hard disk, etc.)

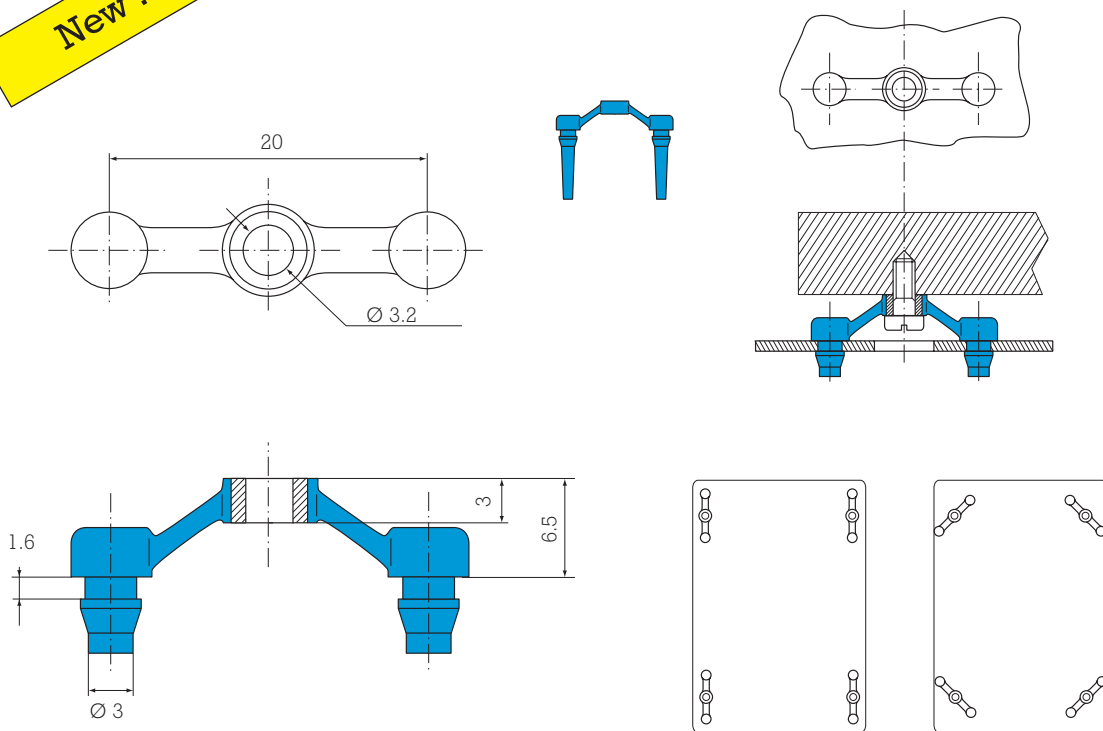

Reference **E4330-F11**

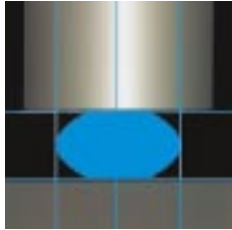

LONG TRAVEL AIR SPRING

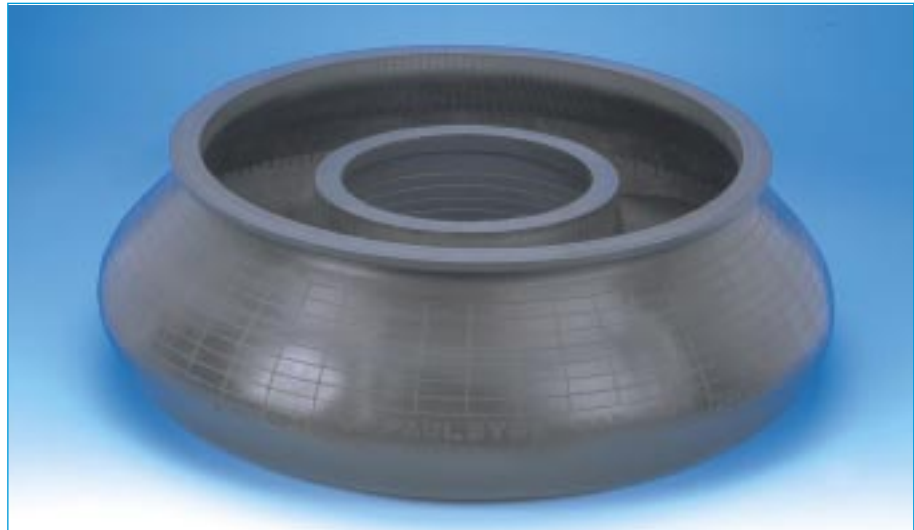

(1) Natural frequency :
1 Hz

DESCRIPTION

The PAULSTRA air spring is a rubber-coated flexible structure seated and sealed with internal and external steel supports.

OPERATION

The air spring is designed to have the following basic properties :

- Low natural frequency.
- Lateral stiffness.
- Adjustable height.
- Withstands adverse weather conditions and temperatures from - 40°C to + 70°C.

(1) Natural frequency with max. load, see chapter : OPERATING CHARACTERISTICS.



OPERATING CHARACTERISTICS

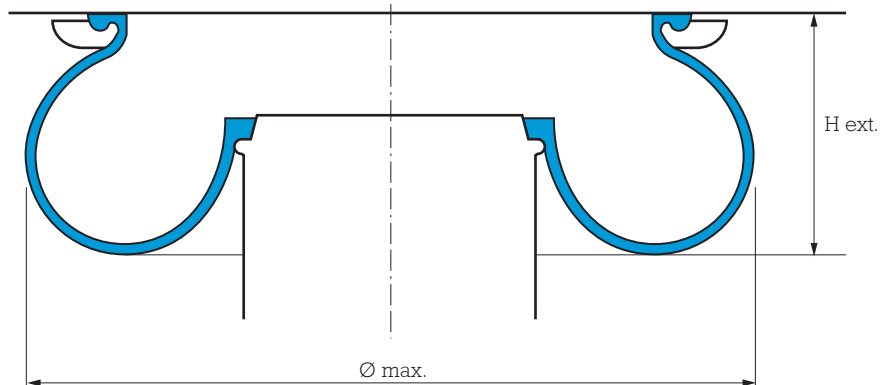

Reference	H int. mm	H ext. mm	Ø max. at 6 bars (mm)	Maximum static load Kn	Natural frequency* Hz	Stiffness at 120 kN/m
545023	120	250	800	160	1	62

* Without additional chamber.

ASSEMBLY

The air spring must be mounted on an upper plate using a flange the same shape as the air spring to provide a good seal. The lower part of the membrane may rest on a rigid support with a restraining and sealing bead.

PAULSTRA also offers a flexible mounting for the air spring to enable the suspension to be used in non-standard applications or under torsion.

Ask us for details of the mounting dimensions.

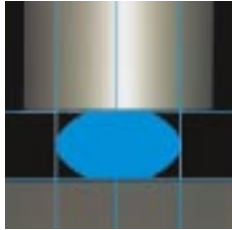

HEAVY DUTY FENDERS

Compression fender

Reference **539634**

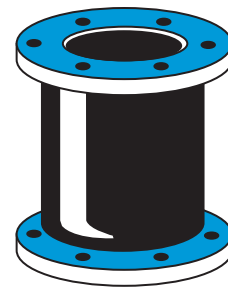
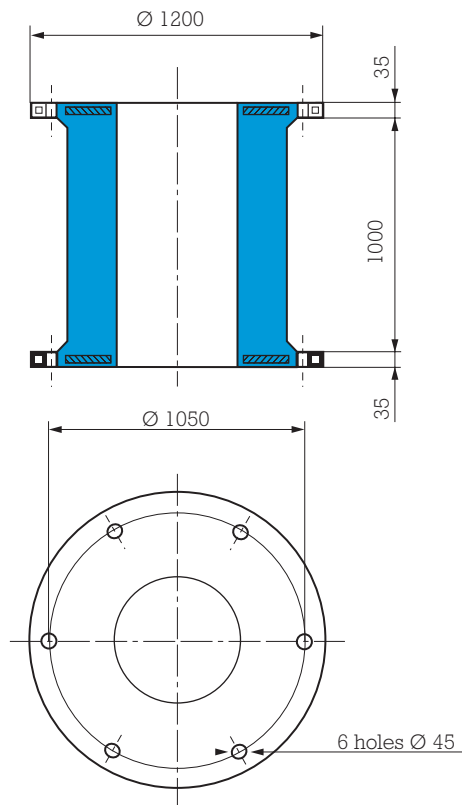

Energy (Joules)	280 000
Force (tonnes)	83
Deflection (m)	0.45
Max Force (tonnes)	166

Trapezoidal shock fender

Reference **519786**

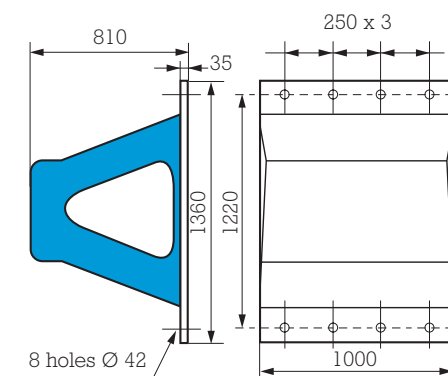

Energy (Joules)	200 000
Force (tonnes)	60
Deflection (m)	0.4

Trapezoidal shock fender

Reference 519794

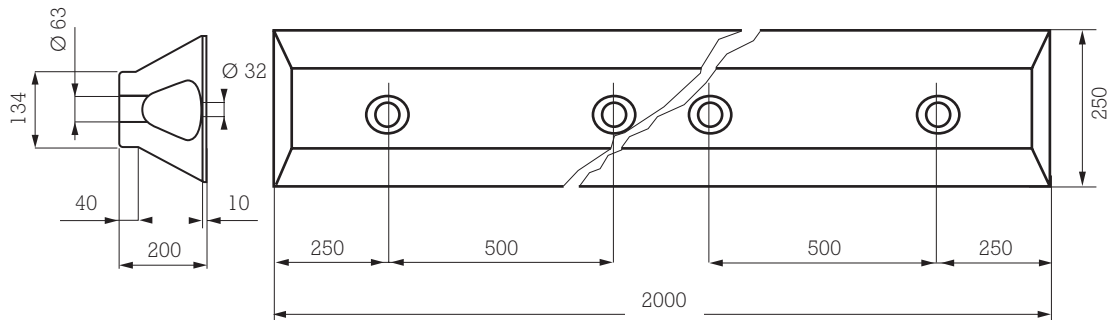

Intermediate lengths on request

Characteristics for a length of 1 m

Energy (Joules)	14 000
Force (tonnes)	15
Deflection (m)	0.1

Protection ring

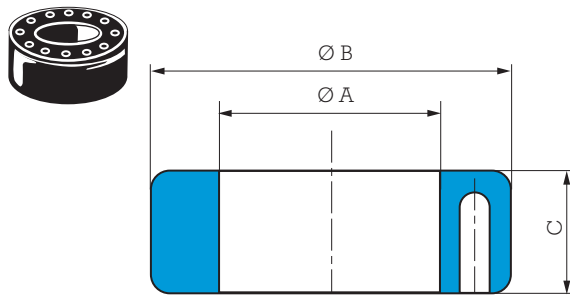

Force is dependent on fixing.
Consult us for information.

Reference	Max radial load (tonne)	Max axial load (tonne)	Weight (kg)
811203	40	70	70
811189	90	150	115

Dimensions

Reference	A (mm)	B (mm)	C (mm)
811203	482.4	787.4	228.6
811189	533	864	300

Shock fender to shear

Reference 539652

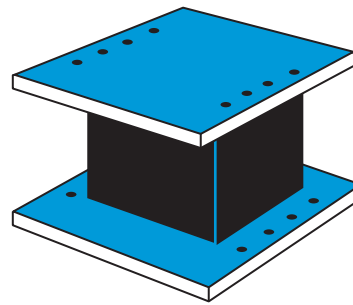
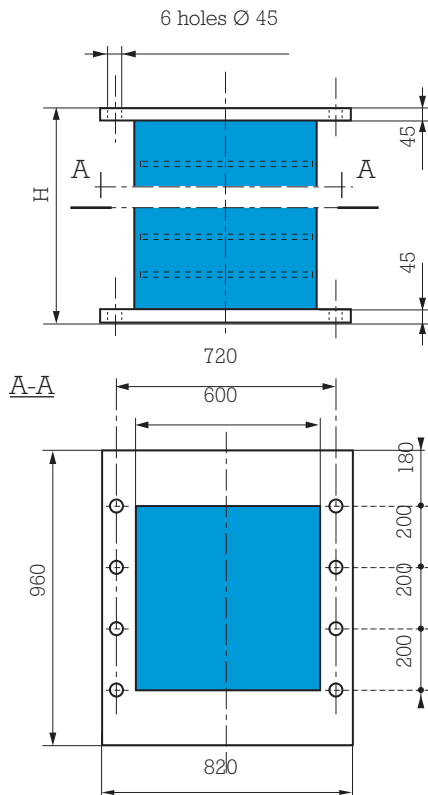

Weight # 755 kg
Height (mm) = 700 ± 5

Energy (Joules)	1 100 000
Force in shear (tonnes)	36
Deflection in shear (m)	0.62
Compression static load (tonnes)	40
Compression static deflection (mm)	30

Rectangular buffer

Reference 519782

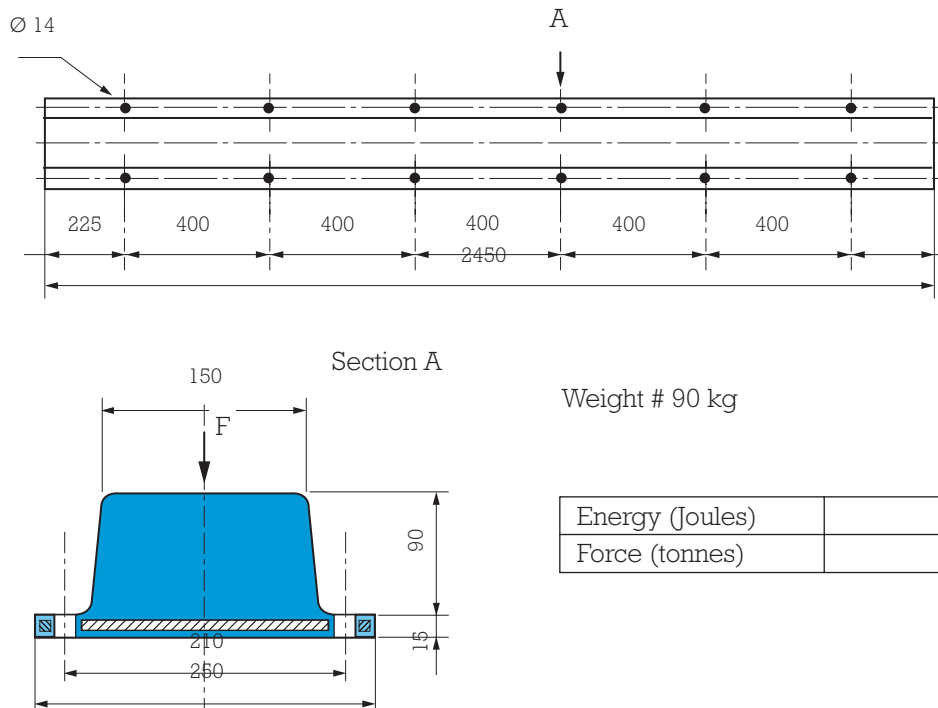

Weight # 90 kg

Energy (Joules)	8 000
Force (tonnes)	150

Intermediate lengths on request.

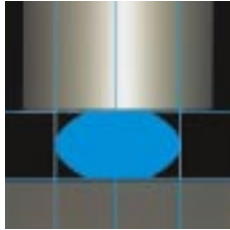

STRASONIC®

New !



DESCRIPTION

STRASONIC is a range of complex materials designed to provide the best acoustic isolation. Their structure is based on polyurethane foams or cellular rubber.

Their main function is to reduce airborne noise (Isolation, Absorption and Damping) in partial or complete enclosures of machinery.

APPLICATIONS

The STRASONIC material can be used in a range of applications such as : air conditioning, pumps, presses, compressors, electric motors diesel engines, generator sets, gearboxes, turbines, agricultural or construction equipment and other machinery.

Due to their design (Sheets of 500 mm x 500 mm or 500 mm x 700 mm) they are easy to handle, light and a self adhesive side simplifies the installation (depending of the type of foam).

CHARACTERISTICS OF THE STRASONIC® RANGE

POLYURETHANE FOAMS

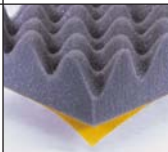
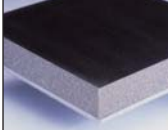
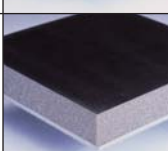
Reference	Structure	Composition and properties	Acoustic performances	Applications
841000		50 mm of corrugated PU Ether absorption foam. Self adhesive layer on one side. Temperature range: from - 25°C to + 110°C. Fire resistance: M4/UL94.	Average absorption factor K: 65% Approximate gain on a 2 mm steel sheet: - 10 dB (A). The corrugations increase the absorption surface by 40%.	- Air conditioning, - Fans, - Ventilation shaft - Pumps - Presses, - Air compressors, ...
841001 841001-50		50 mm of heavy weight 5 kg/m ² , corrugated PU Ether absorption foam bonded to 3 mm of spring foam. Temperature range: from - 25°C to + 110°C. Fire resistance: M4/UL94.	Average absorption factor K: 68%. Approximate gain on a 2 mm steel sheet: - 25 dB (A). Very good performance from 500 Hz to 5000 Hz.	- Air compressors, - Gearboxes, - Presses, - Compressors, - Electric motors , ...
841002		100% waterproof black PU film bonded to 25 mm of heavy weight 5 kg/m ² corrugated PU Ether absorption foam bonded to 3 mm of spring foam. Temperature range: from - 25°C to + 110°C. Fire resistance: M4/UL94.	Approximate gain on a 2 mm steel sheet: - 20 dB (A). Very good performance from 125 Hz to 4000 Hz.	- Generator sets, - Agricultural and Construction, equipment machines, - Electric and Diesel engines, - Compressors, Pumps, - Turbines - Test benches, ...

Reference 841001-50: Self adhesive layer on one side version.



Format: sheets of 500 mm x 700 mm.

To adhere the sheets (part number 841001 and 841002) we recommend the STRAGLUE®

Ref.	Packaging	Color	Density	Drying time	Temperature resistance	Solver	Advised quantity
841010	Can 5 litres	Soft brown	0.89 g/ml	1 to 3 minutes	≈ 80°C	Hydrocarbon	120 g/m ² /face
841011	Can 1 litre	Soft brown	0.89 g/ml	1 to 3 minutes	≈ 80°C	Hydrocarbon	120g/m ² /face

Please consult us for availability of the adhesive (non stocked item).

CELLULAR RUBBER

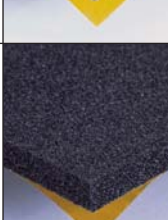
Reference	Structure	Composition and properties	Acoustics performances	Applications
841003		NBR based waterproof cellular rubber, thickness 33 mm. Self adhesive layer on one side. Temperature range static from - 40°C to + 105°C continuous. Very good resistance to oil, ozone, air and UV. Fire resistance: M4/FMVSS 302.	Average absorption factor K ≥ 30% from 500 Hz. Very good acoustic performance in high frequencies above 2500 Hz. Approximate gain on a 2 mm steel sheet: - 10 dB (A) at 2500 Hz / - 20 dB (A) at 5000 Hz.	- Sand blasting systems, Saws, - High speed drills, - Vacuum pumps, - Injection presses, - Gearboxes...
841004		EPDM based cellular rubber with half closed cells. Thickness 15 mm. Self adhesive layer on one side. Temperature range continuous from - 40°C to + 130°C. Very good resistance to air, ozone and UV. Very flexible. Good ageing resistance. Waterproof if slightly compressed. Fire resistance: FMVSS 302.	Average absorption factor K ≥ 30% from 600 Hz. Very good acoustic performance in high frequencies above 2000 Hz. Approximate gain on a 2 mm steel sheet: - 8 dB (A) at 2500 Hz / - 20 dB (A) at 5000 Hz.	- Air Jet positioning, - Sand blasting systems, Saws, - High speed drills, - Vacuum pumps, - Injection presses, - Gearboxes...
841005		EPDM based cellular rubber half closed cells. Thickness 22.5 mm. Self adhesive layer on one side. Temperature range continuous from - 40°C to + 130°C. Very good resistance to air, ozone and UV. Very flexible. Good ageing resistance. Waterproof if slightly compressed. Fire resistance: FMVSS 302.	Average absorption factor K ≥ 30% from 500 Hz. Very good acoustic performance in high frequencies above 2000 Hz. Approximate gain on a 2 mm steel sheet: - 10 dB (A) at 2500 Hz / - 27 dB (A) at 5000 Hz.	- Air Jet positioning, - Sand blasting systems, Saws, - High speed drills, - Vacuum pumps, - Injection presses, - Gearboxes...

Format: sheets of 500 mm x 500 mm.

ALPHABETIC INDEX - PAULSTRA RANGE

Designation	Reference	Page	Designation	Reference	Page	Designation	Reference	Page
Batra	541050	71	Diabolo stud	521300	37	Evidgom	810780	56-57
Batra	541082	71	Diabolo stud	521403	37	Evidgom	810784	56-57
Batra	541083	71	Diabolo stud	521571	37			
Batra	541100	71	Diabolo stud	521572	37	Isodyne	551321	80
Batra	541112	71	Diabolo stud	521602	37	Isodyne	551441	80
Batra	541144	71	Diabolo stud	521801	37	Isodyne	551571	80
Batra	541145	71	Diabolo stud	521802	37			
Batra	541146	71	Diabolo stud	521951	37	Isoflex	552231	78
Batra	541174	71				Isoflex	552241	78
Batra	541175	71	Eligo	537000	85	Isoflex	552428	78
Batra	541185	71	Eligo	537001	85			
Batra	541249	71	Eligo	537007	85	Heavy duty fender	539652	100
Batra	541250	71	Eligo	537070	85	Heavy duty fender	539634	99
			Eligo	537114	85			
Beca	533108	73	Eligo	537115	85	Levaflex	514085	62
Beca	533109	73	Eligo	537116	85	Levaflex	514110	62
Beca	533151	73	Eligo	537117	85	Levaflex	514130	62
Beca	533152	73	Eligo	537119	84	Levaflex	514160	62
Beca	533202	73	Eligo	537120	85	Levaflex	514200	62
Beca	533203	73	Eligo	537137	85			
Beca	533581	73	Eligo	537144	85	Locomotive mounting	538040	92
Beca	533609	73				Locomotive mounting	539437	92
Beca	533623	73	Engine mountings	905201	50	Locomotive mounting	539586	92
Beca	533641	73	Engine mountings	905202	50	Locomotive mounting	539873	92
Beca	533652	73	Engine mountings	905203	50	Locomotive mounting	544059	92
Beca	533661	73	Engine mountings	905206	50	Locomotive mounting	544099	92
Beca	533681	73						
			Triaxdyn	905233	48	Minifix	530801	67
Bogie mounting	539549	94				Minifix	530802	67
			Evidgom	810002	56	Minifix	530805	67
Chevron mounting	539952	94	Evidgom	810003	56	Minifix	530806	67
			Evidgom	810004	62	Minifix	530807	67
Mounting	514202	86	Evidgom	810005	56			
			Evidgom	810006	56	Mounting	E4330-F11	96
Chevron mounting	538000	94	Evidgom	810008	56			
Chevron mounting	539376	94	Evidgom	810009	56	Mounting	534501	86
Chevron mounting	539555	94	Evidgom	810012	56	Mounting	813501	86
Chevron mounting	544066	94	Evidgom	810013	56	Mounting	813504	86
			Evidgom	810014	56	Mounting	813505	86
Conical bump stop	512215	61	Evidgom	810015	56	Mounting	813506	86
Conical Bump stop	512251	61	Evidgom	810016	56	Mounting	817505	86
Conical bump stop	521301	61	Evidgom	810019	56	Mounting	817605	86
Conical bump stop	512307	61	Evidgom	810020	56			
Conical bump stop	512501	61	Evidgom	810022	62	Mounting	530170	89
Conical bump stop	512502	61	Evidgom	810023	62	Mounting	534079	96
Conical bump stop	512503	61	Evidgom	810025	62	Mounting	534135	95
Conical bump stop	512516	61	Evidgom	810029	62	Mounting	538076	90
Conical bump stop	512517	61	Evidgom	810035	62	Mounting	539004	91
Conical bump stop	512601	61	Evidgom	810046	62	Mounting	539743	91
Conical bump stop	512608	61	Evidgom	810642	62	Mounting	539515	96
Conical bump stop	512700	61	Evidgom	810644	62	Mounting	539214	90
Conical bump stop	512721	61	Evidgom	810645	62	Mounting	539024	95
Conical bump stop	512951	61	Evidgom	810653	62	Mounting	539377	90
			Evidgom	810655	62	Mounting	539243	95
Cylindrical Sandwich	539796	84	Evidgom	810666	62	Mounting	539925	93
Cylindrical Sandwich	539900	84	Evidgom	810669	62	Mounting	539971	93
Cylindrical Sandwich	539904	84	Evidgom	810731	62	Mounting	539972	93
Cylindrical Sandwich	539937	84	Evidgom	810732	62	Mounting	544172-11	89
Cylindrical Sandwich	539938	84	Evidgom	810733	56-57			
Cylindrical Sandwich	539983	84	Evidgom	810734	62	Nivofix	530810	66
Cylindrical Sandwich	544078	84	Evidgom	810735	62	Nivofix	530815	66
Cylindrical Sandwich	544079	84	Evidgom	810736	56-57	Nivofix	530820	66
Cylindrical Sandwich	544080	84	Evidgom	810766	56-57	Nivofix	530825	66
			Evidgom	810768	56-57	Nivofix	530830	66
Diabolo bump stop	511571	61	Evidgom	810769	56-57	Nivofix	530835	66
Diabolo bump stop	511572	61	Evidgom	810770	56-57	Nivofix	530840	66
Diabolo bump stop	511601	61	Evidgom	810773	56-57	Nivofix	530850	66
Diabolo bump stop	511801	61	Evidgom	810775	56-57			
Diabolo bump stop	511951	61	Evidgom	810776	56-57	Paulstradyn	533701	39-41
Diabolo stud	521201	37	Evidgom	810779	56-57	Paulstradyn	533702	39-41

Designation	Reference	Page	Designation	Reference	Page	Designation	Reference	Page
Radiaflex stud	521843	35	S.C. mounting	531201	52-53	Stabifix	530184	46
Radiaflex stud	521908	35	S.C. mounting	531216	52-53	Stabifix	530185	46
Radiaflex stud	521909	35	S.C. mounting	531240	52-53			
Radiaflex stud	521910	35	S.C. mounting	531259	52-53	Stabiflex	530603	43
			S.C. mounting	531261	52-53	Stabiflex	530613	43
Rectangular buffer	519782	101	S.C. mounting	531301	52-53	Stabiflex	530622	43
			S.C. mounting	531327	52-53	Stabiflex	530642	43
Sandwich	519821	83	S.C. mounting	531401	52-53	Stabiflex	530652	43
Sandwich	519822	83	S.C. mounting	531402	52-53			
Sandwich	519823	83	S.C. mounting	531611	52-53	S.T.C.	539190	59
Sandwich	534455	84	S.C. mounting	531701	52-53	S.T.C.	539191	59
Sandwich	534456	84	S.C. mounting	531702	52-53	S.T.C.	539886	59
Sandwich	534646	84	S.C. mounting	531714	52-53	S.T.C.	539887	59
Sandwich	534647	84	S.C. mounting	531931	52-53	S.T.C.	539920	59
Sandwich	539267	83	S.C. mounting	531932	52-53	S.T.C.	539951	59
Sandwich	539520	83	S.C. mounting	531933	52-53			
Sandwich	539537	83	S.C. mounting	531939	52-53	Strasonic	841000	103
Sandwich	539607	83	S.C. mounting	531940	52-53	Strasonic	841001	103
Sandwich	539608	83	S.C. mounting	531941	52-53	Strasonic	841001-50	103
Sandwich	539612	83	S.C. mounting	531947	52-53	Strasonic	841002	103
Sandwich	539613	83				Strasonic	841003	103
Sandwich	539701	83	S.C.P. mounting	530120	76	Strasonic	841004	103
Sandwich	539820	83	S.C.P. mounting	530220	76	Strasonic	841005	103
Sandwich	539821	83	S.C.P. mounting	530420	76			
Sandwich	539823	83				Straglue	841010	103
Sandwich	539832	83	S.L.F.	555005	81	Straglue	841011	103
Sandwich	539833	83	S.L.F.	555006	81			
Sandwich	539835	83	S.L.F.	555007	81	Trapezoidal fender	519786	99
Sandwich	539890	83				Trapezoidal fender	519794	100
Sandwich	539898	84	Special bump stop	512389	87			
Sandwich	539903	83	Special bump stop	512991	87	Traxiflex	535600	69
Sandwich	539917	84	Special bump stop	519186	87	Traxiflex	535603	69
Sandwich	539924	83	Special bump stop	519805	88	Traxiflex	53560631	69
Sandwich	539933	83	Special bump stop	519830	88	Traxiflex	535611	69
Sandwich	539939	83				Traxiflex	535612	69
Sandwich	539940	84	Stabifix	530170	46	Traxiflex	535621	67
Sandwich	539992	83	Stabifix	530175	46	Traxiflex	535622	67
Sandwich	544051	84	Stabifix	530181	46	Triaxdyn	905233	46

NUMERIC INDEX - PAULSTRA RANGE

Reference Designation	Page	Reference Designation	Page	Reference Designation	Page
E3RP0953	35	512251	61	520041	36
E3RP0956	35	512301	61	520042	36
		512307	61	520044	36
E4330-F11 Mounting	96			520045	36
511110	35-59	512389	87	520046	36
511115	35-59			520053	36
511125	35-59	512501	61	520054	36
511128	35-59	512502	61	520100	36
511150	35-59	512503	61	520101	36
511151	35-59	512516	61	520102	36
511152	36-59	512517	61	520103	36
511153	36-59	512601	61	520500	36
511154	36-59	512608	61	520501	36
511155	35-59	512700	61	520502	36
511156	36-59	512721	61	520503	36
511157	35-59	512951	61	520505	36
511158	35-59			520506	36
511159	35-59	512991	87	520507	36
511160	35-59			520508	36
511161	35-59	513601	35	520511	36
511162	36-59	513801	35-61	520512	36
511163	36-59			520513	36
511164	36-59	514085	62	520514	36
511200	35-59	514110	62	520516	36
511215	35-59	514130	62	520517	36
511220	35-59	514160	62	520518	36
511225	35-59	514200	62	520520	36
511230	35-59			520521	36
511251	35-59	514202	86	520522	36
511265	35-59			520523	36
511270	35-59	519186	87	520525	36
511275	35-59	519389	87	520526	36
511280	35-59	519805	88	520528	36
511285	35-59	519830	88	520529	36
511290	35-59			520530	36
511292	35-59	519782	101	520531	36
511294	35-59			520532	36
511296	35-59	519786	99	520534	36
511298	35-59	519794	100	520535	36
511308	35-59			520536	36
511310	35-59	519821	83	520541	36
511312	35-59	519822	83	520542	36
511314	35-59	519823	83	520543	36
511401	35-59			520545	36
511450	35-59	520010	36	520546	36
511452	35-59	520011	36	520547	36
511454	35-59	520012	36	520550	36
511456	35-59	520013	36	520551	36
511525	35-59	520015	36	521128	36
511535	35-59	520016	36	521178	36
511545	35-59	520017	36		
		520018	36	521201	37
511571	61	520021	36		
511572	61	520022	36	521249	35
511601	61	520023	36	521251	35
		520024	36	521292	35
511625	35-61	520025	36	521293	35
511635	35-61	520026	36	521294	35
511645	35-61	520027	36	521295	35
511735	35-61	520028	36	521296	35
511750	35-61	520029	36	521297	35
511770	35-61	520030	36	521298	35
		520031	36	521299	35
511801	61	520032	36		
		520033	36	521300	37
511830	35-61	520035	36		
511840	35-61	520036	36	521308	35
511870	35-61	520038	36	521310	35
511880	35-61	520039	36	521312	35
		520040	36	521314	35
511951	61				
512215	61				

Reference Designation	Page	Reference Designation	Page	Reference Designation	Page
521319	35	530840	66	534647	84
521340	35	530850	66		
521341	35			535600	69
521342	35	531201	52-53	535603	69
521343	35	531216	52-53	53560361	69
521344	35	531240	52-53	535611	69
521401	35	531259	52-53	535612	69
		531261	52-53	535621	69
521403	37	531301	52-53	535622	69
		531327	52-53		
521450	35	531401	52-53	537000	85
521452	35	531402	52-53	537001	85
521454	35	531611	52-53	537007	85
521456	35	531701	52-53	537070	85
		531702	52-53	537114	85
521571	37	531714	52-53	537115	85
521572	37	531931	52-53	537116	85
		531932	52-53	537117	85
521580	35	531933	52-53	537119	85
521581	35	531939	52-53	537120	85
521582	35	531940	52-53	537137	85
521601	35	531941	52-53	537144	85
		531947	52-53		
521602	37			538000	94
		532300	75		
521603	35	532500	75	538040	92
521641	35	532561	75		
521650	35	532563	75	538076	90
521651	35	532750	75	539004	91
521705	35			539024	95
521710	35	533108	73		
521711	35	533109	73	539190	59
		533151	73	539191	59
521801	37	533152	73		
521802	37	533202	73	539214	90
		533203	73	539243	95
521803	35	533581	73		
521840	35	533609	73	539267	83
521841	35	533623	73		
521842	35	533641	73	539376	94
521843	35	533652	73		
521908	35	533661	73	539377	90
521909	35	533681	73		
521910	35			539437	92
		533701	39-41		
521951	37	533702	39-41	539515	96
		533703	39-41		
530120	76	533704	39-41	539520	83
		533705	39-41	539537	83
530170	46	533706	39-41		
530175	46	533707	39-41	539539	84
530181	46	533708	39-41		
530184	46	533709	39-41	539549	94
530185	46	533710	39-41	539555	94
		533711	39-41		
530220	76	533712	39-41	539586	92
530420	76	533713	39-41		
		533714	39-41	539607	83
530603	43	533715	39-41	539608	83
530613	43	533716	39-41	539612	83
530622	43	533717	39-41	539613	83
530642	43	533718	39-41		
530652	43	533719	39-41	539634	99
				539652	101
530805	67	534079	96	539701	83
530806	67	534135	95		
				539743	91
530810	66	534455	84		
530815	66	534456	84	539796	84
530820	66				
530825	66	534501	86	539806	84
530830	66			539820	83
530835	66	534646	84	539821	83

Reference Designation	Page	Reference Designation	Page	Reference Designation	Page			
539823	Sandwich	83	541145	Batra	71	810029	Evidgom	62
539832	Sandwich	83	541146	Batra	71	810035	Evidgom	62
539833	Sandwich	83	541174	Batra	71	810046	Evidgom	62
539835	Sandwich	83	541175	Batra	71	810642	Evidgom	62
			541185	Batra	71	810644	Evidgom	62
539873	Locomotive mounting	92	541249	Batra	71	810645	Evidgom	62
			541250	Batra	71	810653	Evidgom	62
539886	S.T.C.	59				810655	Evidgom	62
539887	S.T.C.	59	544051	Sandwich	84	810666	Evidgom	62
						810669	Evidgom	62
539890	Sandwich	83	544059	Locomotive mounting	92	810731	Evidgom	62
539898	Sandwich	84				810732	Evidgom	62
			544066	Chevron mounting	94	810733	Evidgom	56-57
539900	Cylindrical sandwich	84				810734	Evidgom	62
			544078	Cylindrical sandwich	84	810735	Evidgom	62
539903	Sandwich	83	544079	Cylindrical sandwich	84	810736	Evidgom	56-57
			544080	Cylindrical sandwich	84	810766	Evidgom	56-57
539904	Cylindrical sandwich	84				810768	Evidgom	56-57
			544099	Locomotive mounting	92	810769	Evidgom	56-57
539917	Sandwich	84				810770	Evidgom	56-57
			545023	Pneumatic mounting	99	810773	Evidgom	56-57
539920	S.T.C.	59	544172-11	Mounting	89	810775	Evidgom	56-57
						810776	Evidgom	56-57
539924	Sandwich	83	551321	Isodyne	80	810779	Evidgom	56-57
			551441	Isodyne	80	810780	Evidgom	56-57
539925	Support	83	551571	Isodyne	80	810784	Evidgom	56-57
539933	Sandwich	83	552231	Isoflex	78	811189	Protection ring	100
539937	Cylindrical sandwich	84	552241	Isoflex	78	811203	Protection ring	100
539938	Cylindrical sandwich	84	552428	Isoflex	78			
						813501	Mounting	86
539939	Sandwich	83	555005	S.L.F.	81	813504	Mounting	86
539940	Sandwich	84	555006	S.L.F.	81	813506	Mounting	86
			555007	S.L.F.	81	817505	Mounting	86
						817605	Mounting	86
539951	S.T.C.	59	810002	Evidgom	56	841000	Strasonic	103
			810003	Evidgom	56	841001	Strasonic	103
539952	Chevron mounting	94	810004	Evidgom	62	841001-50	Strasonic	103
			810005	Evidgom	56	841002	Strasonic	103
539971	Mounting	93	810006	Evidgom	56	841003	Strasonic	103
539972	Mounting	93	810008	Evidgom	56	841004	Strasonic	103
			810009	Evidgom	56	841005	Strasonic	103
539983	Cylindrical sandwich	84	810012	Evidgom	56			
			810013	Evidgom	56	841010	Straglue	103
539992	Sandwich	83	810014	Evidgom	56	841011	Straglue	103
			810015	Evidgom	56			
541050	Batra	71	810016	Evidgom	56	905201	Engine mountings	50
541082	Batra	71	810019	Evidgom	56	905202	Engine mountings	50
541083	Batra	71	810020	Evidgom	56	905203	Engine mountings	50
541100	Batra	71	810022	Evidgom	62	905206	Engine mountings	50
541112	Batra	71	810023	Evidgom	62			
541144	Batra	71	810025	Evidgom	62	905233	Triaxdyn	48



PAULSTRA





VIBRACHOC ELASTOMER RANGE



APPLICATION GUIDE FOR THE VIBRACHOC ELASTOMER RANGE

	VIBMAR	ARDAMP®
APPLICATIONS		
MOBILE OR STATIC FANS		
MOBILE OR STATIC AIR CONDITIONERS		
COMPRESSORS		
MOBILE OR STATIC GENERATOR SETS		
INTERNAL COMBUSTION ENGINES		
LABORATORY EQUIPMENT		
MOBILE OR STATIC ELECTRICAL ENCLOSURES		
FRAGILE EQUIPMENT IN CONTAINERS		
COMPUTER EQUIPMENT		
MOBILE ELECTRONIC EQUIPMENT		
PROTECTION AGAINST SHOCKS AND BUMPS		

APPLICATION GUIDE FOR THE VIBRACHOC ELASTOMER RANGE

SPECIAL PACKAGING	SPECIAL ELECTRONICS	APPLICATIONS
		MOBILE OR STATIC FANS
		MOBILE OR STATIC AIR CONDITIONERS
		COMPRESSORS
		MOBILE OR STATIC GENERATOR SETS
		INTERNAL COMBUSTION ENGINES
		LABORATORY EQUIPMENT
		MOBILE OR STATIC ELECTRICAL ENCLOSURES
		FRAGILE EQUIPMENT IN CONTAINERS
		COMPUTER EQUIPMENT
		SHIPBOARD ELECTRONIC EQUIPMENT
		PROTECTION AGAINST SHOCKS AND BUMPS

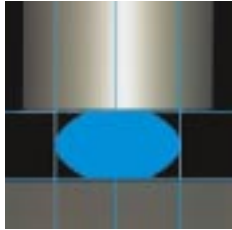

VIBMAR



Natural frequency :
5 to 12 Hz
with nominal load

DESCRIPTION

The VIBMAR series has a base plate with two or four mounting holes and a tapped steel core.
The elastomer is bonded to the steel.

E1N104 and E1N106 versions have a conical spring embedded in the rubber.

Environmental protection is provided by painting the metal parts and by coating the elastomer with an ozone resistant compound.

APPLICATIONS

These multi-axis low frequency dampers have been specially designed to protect electrical or electronic racks and marine or road transport generator sets (on board or not). They are cone-shaped to absorb considerable displacement and shocks.

DIMENSIONS

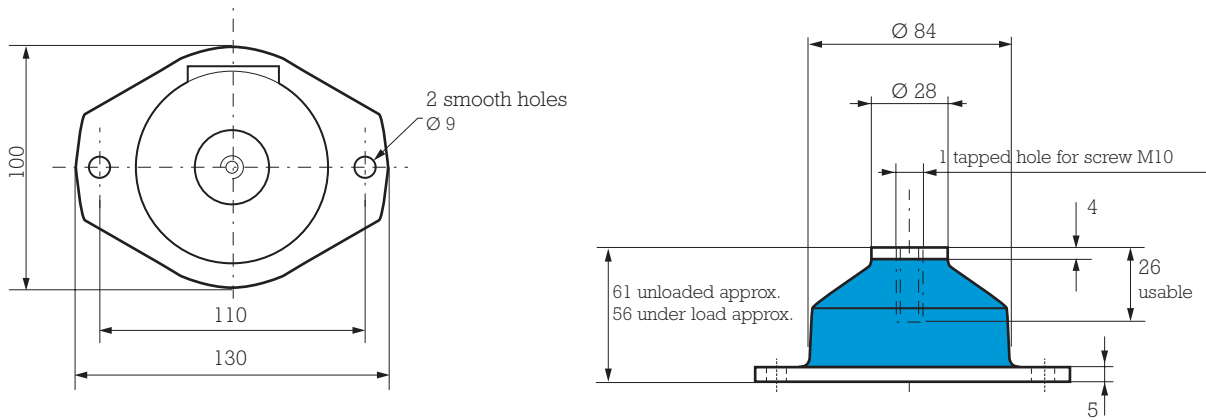

OPERATING CHARACTERISTICS

Natural frequency:

- axial: 8 to 12 Hz
- radial: 6 to 10 Hz.

Maximum permitted excitation at the natural frequency of suspension: ± 1.25 mm.

Maximum axial travel available for shocks: 30 mm.

Amplification factor at resonance: < 6 and < 4 for silicone rubber versions.

Structural strength corresponding to a continuous acceleration of 3 g with maximum load.

When suspending an enclosure, the same type of damper should be used as a stabiliser.

Operating temperature: -30°C to $+100^{\circ}\text{C}$.

-54°C to $+150^{\circ}\text{C}$ for silicone rubber versions.

Weight: 0.6 kg.

SILICONE RUBBER VERSIONS

Reference	Static loads in daN
E1N2296-01	17-30
E1N2296-02	35-55
E1N2296-03	55-70

Reference	Static loads in daN
E1N2296 S01	10-18
E1N2296 S02	17-25
E1N2296 S03	20-30

1 kg \approx 1 daN

Note: Product available with stainless steel plates (ref. E1N-3217) and/or alternative elastomers. Please consult us.

VIBMAR E1N101

DIMENSIONS

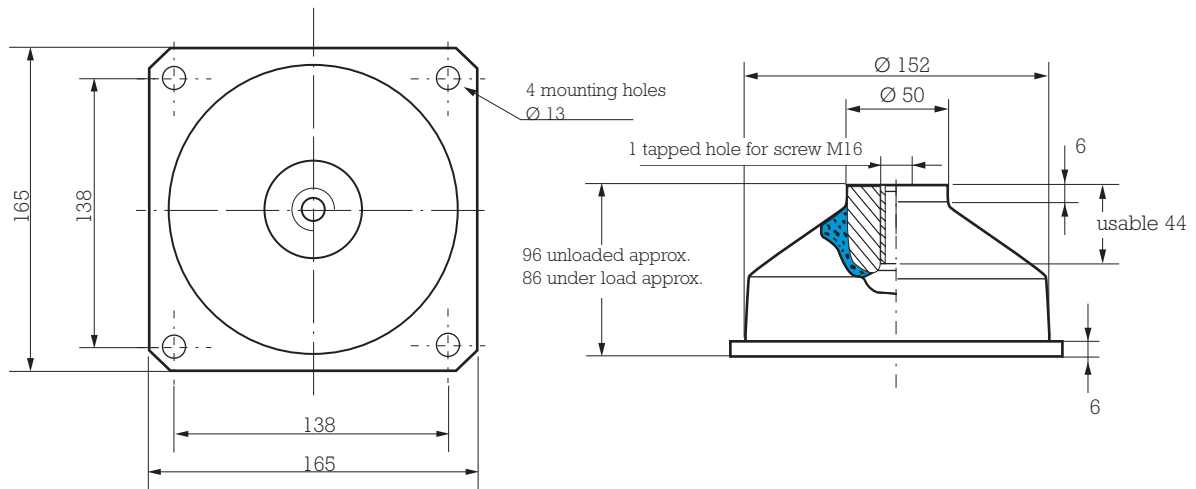

OPERATING CHARACTERISTICS

Natural frequency:

- axial: 5 to 9 Hz
- radial: 4.5 to 9 Hz.

Maximum permitted excitation at natural frequency of suspension: ± 1.5 mm.

Maximum travel available for shocks: 30 mm in all directions

Amplification factor at resonance: grade 01 to 04 < 6.
grade 05 to 06 < 10.

Weight: 2 kg.

Reference	Static loads in daN
E1N101-01	50 - 85
E1N101-02	85 - 120
E1N101-03	100 - 150
E1N101-04	130 - 210
E1N101-05	210 - 310
E1N101-06	310 - 530

1 kg \approx 1 daN

Note: Product available with stainless steel plates and/or alternative elastomers on special request. Please consult us.

DIMENSIONS

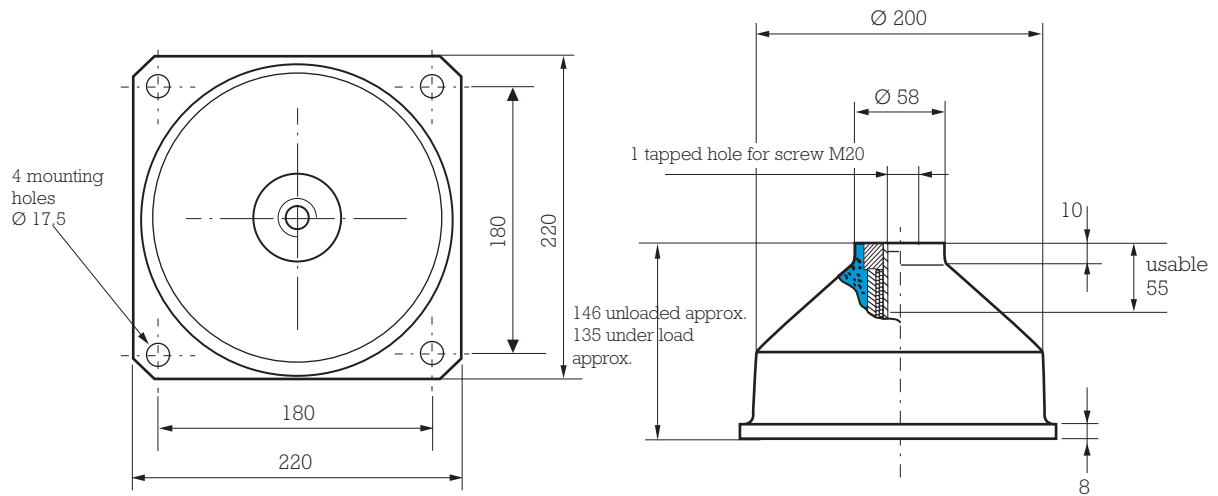

OPERATING CHARACTERISTICS

Natural frequency :

- axial : 5 to 7 Hz
- radial : 6 to 8 Hz.

Maximum permitted excitation at the natural frequency of suspension : ± 1.5 mm.

Amplification factor at resonance : $04 < Q < 10$.

Maximum axial travel available for shocks : - axial ± 45 mm.

- radial ± 25 mm.

Structural strength corresponding to a continuous acceleration of 10 g with maximum load.

Weight : 2 kg.

Reference	Static loads in daN
E1N104C45AS	200 - 360
E1N104C60AS	360 - 600
E1N104C75AS	500 - 800
E1N106C60AS	700 - 1000
E1N106C75AS	900 - 1300

Note : the mountings may be moulded in other compounds to meet special environmental requirements. Ask us for details.

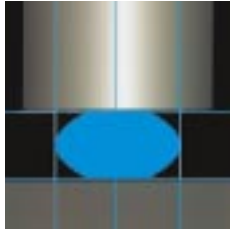

“X” TYPE FLEXIBLE MOUNTINGS



Natural frequency :
4 to 10 Hz
under nominal load

DESCRIPTION

Steel mounting with excellent shock absorption capacity, highly resistant to fatigue.

It is made of a stainless steel and epoxy resin sandwich which limits the amplification.

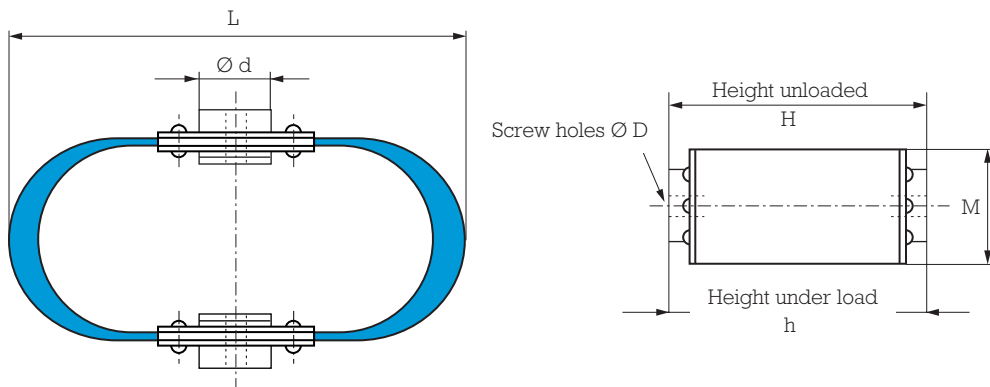

VIBRACHOC reference	Nominal load daN	H mm	h mm	L mm	M mm	Ø d mm	Ø D mm
E1M-3950-01	10	114.3	106.9	203.2	50.8	31.8	8
E1M-3951-01	20	114.3	106.9	203.2	50.8	31.8	8
E1M-3952-01	45	133.3	123.2	215.9	50.8	31.8	12
E1M-3953-01	70	133.3	123.6	215.9	50.8	31.8	12
E1M-3954-01	110	133.3	124.2	215.9	50.8	31.8	12
E1M-3955-01	180	190.5	185.4	297.2	101.6	63.5	20
E1M-3956-01	320	190.5	183.4	297.2	101.6	63.5	20
E1M-3957-01	450	190.5	184.4	297.2	101.6	63.5	20
E1M-3958-01	450	209.6	199.3	365.0	50.8	34.9	3/4"

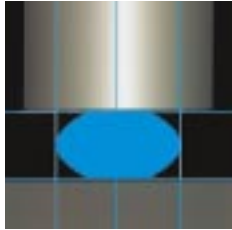

ARDAMP®



Natural frequency :
10 to 25 Hz
under nominal load

DESCRIPTION

The ARDAMP series dampers have a spring and piston embedded in high viscosity silicone rubber gel which itself is embedded in an elastomer membrane bonded to the case.

APPLICATIONS

Due to their high performances and high shock damping capacity ARDAMP dampers are designed to protect fragile electronic equipment, control panels and measuring instruments on ground vehicles, aircrafts, helicopters, civil and military submersible craft.

DIMENSIONS

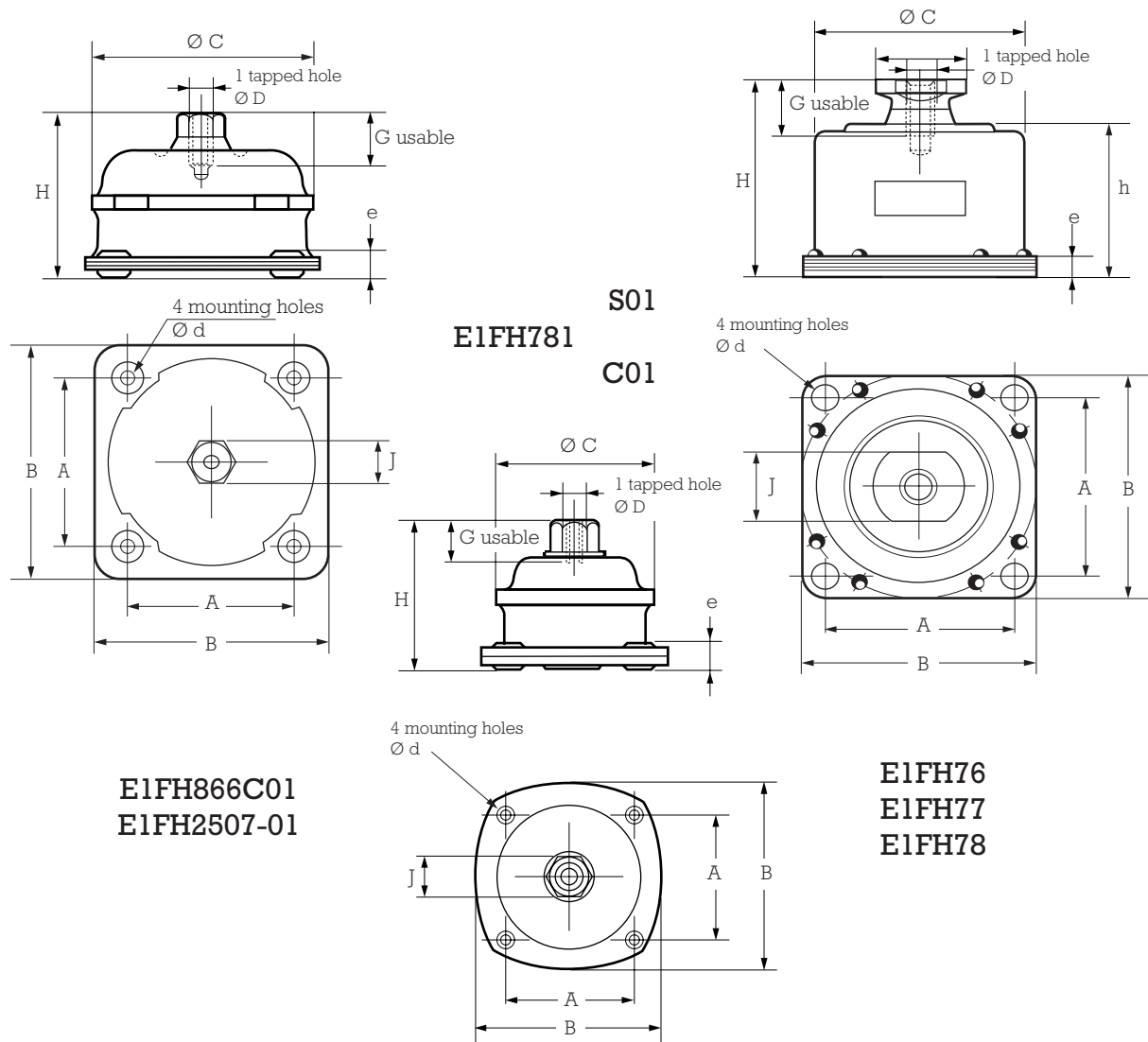

Reference	H Unload. mm	H approx. under load mm	$\varnothing A$ mm	B mm	C mm	$\varnothing D$	E mm	G maxi mm	J mm	d mm	e mm	h mm	Weight approx.
E1FH781S01 E1FH781C01	42 43	39 41	35	54	43	M5		10	12	4.5	5.5		120 g
E1FH866C01 E1FH2507-01	47	46	49.2	65.3	61.5	M6		15	12	5.2	5		230 g 215 g
E1FH76-01 E1FH76-02	70 67	66 65	63.5	77	70	M10	30	19	24	8.4	7.2	49	390 g
E1FH77-01	86	82	88	110.5	96	M12	40	24	34	8.4	8.5	62	930 g
E1FH78-01 E1FH78-02	102 98	99 95	107.9	132	117	M16	54	25	44	11	9.5	77.5	1.5 kg

OPERATING CHARACTERISTICS

Natural frequency :

- axial : 10 to 25 Hz
- radial : 10 to 20 Hz.

Damping : 20 % e (E1FH781, 866, 2507-01).
17% e (E1FH76, 77, 78).

Amplification factor at resonance : 2.5 to 3 max.

These dampers comply with SEFT 001A, AIR 7304, MIL STD 810 C.

Reference	SEFT 001 A			AIR 7304			MIL STD 810 C		Non standard applications		Shocks and bumps OZ axis	
	Load kg per damper	Axial Fn in Hz	Radial Fn in Hz	Load kg per damper	Axial Fn in Hz	Radial Fn in Hz	Load kg per damper	Axial Fn in Hz	Load kg per damper	Radial Fn in Hz	6 ms ½ sine shocks max input g	11 ms ½ sine shocks max input g
E1FH781S01 E1FH781C01				0.2-2 2-5	20-25	15-20	4	16	1.5-3.5 3.5-8	10-20	70 g	38 g
E1FH866C01 E1FH2507-01	8-15 -	10-20 -	12-20 -	6-8 -	20-25 -	15-20 -	8 -	20 -	8-15 5-8	10-20 6-10	50 g -	27 g -
E1FH76-01 E1FH76-02	14-20 18-30	10-20	12-20 11-16	7-12 9-20	20-25	15-20	14 18	18 17	14-20 18-30	10-20	40 g 55 g	22 g 30 g
E1FH77-01	20-50	10-20	10-17				30	15	20-50	10-20	50 g	25 g
E1FH78-01 E1FH78-02	50-100 90-130	10-20	10-16 10-15				75 100	10 11	50-100 90-130	10-20	40 g	22 g

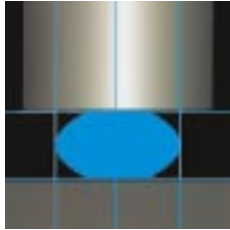

E1C2321

E1T2105

SPECIAL PACKAGING

Natural frequency :
10 to 25 Hz
under nominal load

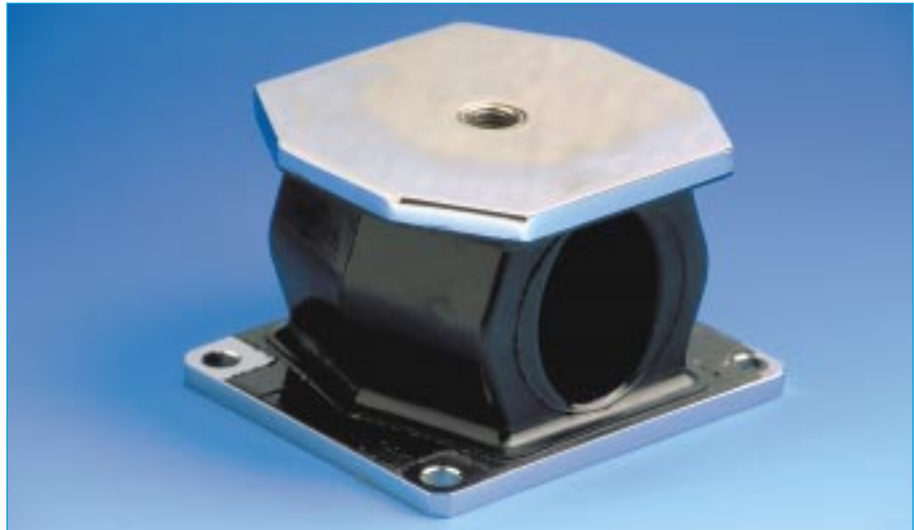

DESCRIPTION

The special packing dampers have a flexible elastomer element designed for various applications, bonded to two steel mounting plates.

APPLICATIONS

These multi-directional dampers allow considerable deflection to protect equipment transported in containers against drops and transport shocks (missiles, aeronautical equipment).

These dampers are also suitable for suspending equipment to be protected against shocks and vibrations caused by explosions or earthquakes.

DIMENSIONS

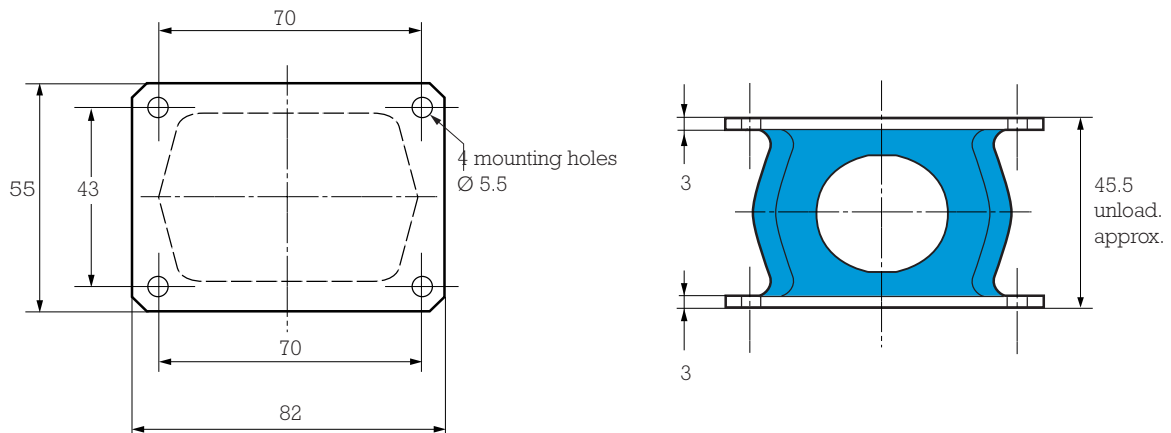

OPERATING CHARACTERISTICS

Natural frequency:

- axial: 10 to 25 Hz
- radial: 10 to 25 Hz.

Maximum permitted excitation at natural frequency of suspension: ± 1.6 mm.

Maximum travel available for shocks: - axial 15 mm.
- radial 40 mm.

Operating temperature: see table.

Weight: 0.3 kg.

Reference	Axial static load in daN	Damping	Resistance to oils and hydrocarbons	Resistance to fatigue	Operating temperature	Material (1)
E1C2321S01	1-10	***	*	*	- 54 to + 150°C	SIL 33 Sh
E1C2321S02	2-20					SIL 55 Sh
E1C2321-01	2-20	*	**	***	- 30 to + 100°C	CR 60 Sh
E1C2321-02	5-50					CR 70 Sh
E1C2321-03	10-100					CR 75 Sh
E1C2321-21	2-20	***	*	***	- 40 to + 90°C	BR 60 Sh
E1C2321-22	5-50					BR 70 Sh
E1C2321-23	10-100					BR 80 Sh

(1) SIL: Silicone ; CR: Chloroprène-Rubber ; BR: Butadiene-Rubber.

1 kg = 1 daN

E1T2105

DIMENSIONS

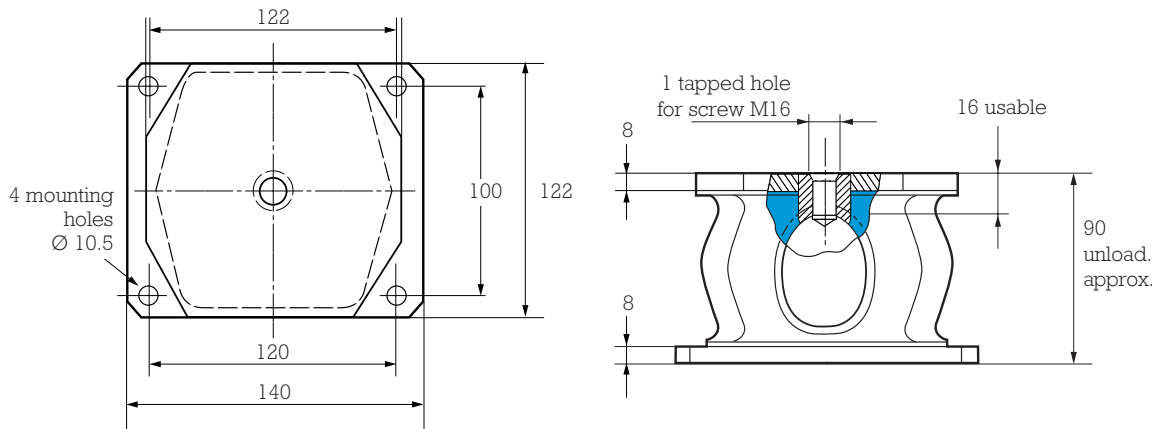

OPERATING CHARACTERISTICS

Natural frequency :

- axial : 10 to 25 Hz
- radial : 10 to 25 Hz.

Maximum permitted excitation at natural frequency of suspension : ± 1.6 mm.

Maximum travel available for shocks : - axial 40 mm.
- radial 75 mm.

Operating temperature : see table.

Weight : 2.6 kgj.

Reference	Axial static load daN	Damping	Resistance to oils and hydrocarbons	Resistance to fatigue	Operating temperature
E1T2105S01 E1T2105S02	2-20 4-40	***	*	*	- 54 to + 150°C
E1T2105-41 E1T2105-42 E1T2105-43	10-100 20-200 50-400	*	***	**	- 25 to + 90°C
E1T2105-21 E1T2105-22 E1T2105-23	10-100 20-200 50-400	***	*	***	- 40 to + 90°C

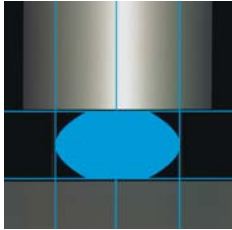

ELASTOMER MOULDED PARTS

SILICONE RUBBER / SPECIAL ELECTRONICS



CHARACTERISTICS

These parts are usually supplied in VHDS (very high density silicone) rubber and the full reference should include:

- the letter S,
- the appropriate grade which corresponds:
 - to the young's modulus of the rubber under static compression in accordance with ASTM D945 (ref. 33 to 77),
 - or to the stiffness measured on a part (ref. 16 to 25).

These standard VIBRACHOC grades are shown in the following table:

Reference	Colour	Characteristics		
		G: Shear modul (MPa)	E: Elast. modul (MPa)	Stiffness (1)(2) (N/mm)
		Tolerance: $\pm 15\%$		Tolerance: $\pm 10\%$
16	yellow			19
20	dark blue			20
25	black			25
33	light blue	0.4	1.2	36
38	grey	0.47	1.4	40
42	brown	0.53	1.6	45
48	dark green	0.6	1.8	50
55	brick red	0.67	2.0	55
63	orange	0.8	2.4	65
72	light green	1	3.0	75
77	ultramarine blue	1.1	3.3	100

(1) measured on standardised $\varnothing 19$ - h 12.7 mm high part.

(2) linear region between 1 to 3 mm compression.

1 kg \approx 1 daN

Example: E3RP0754S55 flat washer internal diameter 7, external diameter 30, height 6, in VHDS silicone, young modulus 2 MPa ; washer colour: brick red.

Other elastomers may be used: natural rubber, neoprene, EPDM, butyl rubber, nitrile rubber.



DIMENSIONS

FLAT WASHERS

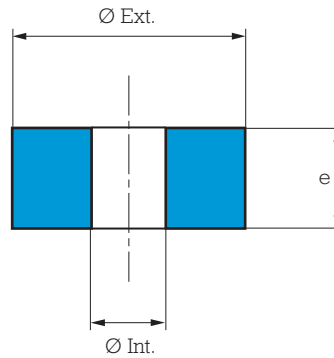

Reference	\varnothing Int. mm	\varnothing Ext. mm	e mm
E3RP2439	2	6	10
E3RP3419	2	7	1
E3RP2062	4	8	5
E3RP3291	4	9	3.4
E3RP2061	4	12	4
E3RP2667	5	12	5
E3RP2025	5	15	4
E3RP2024	5	22	4
E3RP2401	6	18	6
E3RP2282	6.1	12	6
E3RP2281	6.1	20	4
E3RP2959	6.4	12	3
E3RP2453	6.5	11.8	2.5
E3RP2403	6.5	13.5	10
E3RP3534	6.5	15	4.5
E3RP2402	6.5	18	14.5
E3RP3162	6.5	25	2
E3RP2882	7	12	4
E3RP0590	7	12	6
E3RP2883	7	16	6
E3RP0591	7	16	8
E3RP2404	7	30	3
E3RP0754	7	30	6
E3RP2148	7.4	11.5	7.5
E3RP2149	7.6	17.6	6
E3RP2454	7.7	11.8	7.7
E3RP2406	8	13	4
E3RP2405	8	16	4
E3RP0607	8	18	6
E3RP0608	8	18	8
E3RP0588	8	22	4
E3RP0777	8	24	4
E3RP2436	8	26	6
E3RP0609	8	26	10
E3RP2045	8.5	26	4

Reference	\varnothing Int. mm	\varnothing Ext. mm	e mm
E3RP2604	9	13	4
E3RP2605	9	19	4
E3RP2330	9	36	6
E3RP2181	9.5	20	6
E3RP2570	9.5	24	4
E3RP2446	9.5	26	4
E3RP3500	10	18	4
E3RP0613	10	20	6
E3RP2346	10	21	6
E3RP2437	10	22	4
E3RP0584	10	22	6
E3RP2345	10	24	6
E3RP2645	10	25	4
E3RP0614	10	26	6
E3RP0615	10	26	12
E3RP2435	10	30	6
E3RP0644	10	30	12
E3RP0585	10	34	6
E3RP0643	10	34	8
E3RP0586	10	34	12
E3RP2329	11	36	4
E3RP2328	11	36	6
E3RP0694	12	17	4
E3RP0695	12	18	4
E3RP0738	12	50	12
E3RP2407	14	22	6.5
E3RP3222	14	30	3
E3RP2408	16	29	7
E3RP2409	20	32	10.5
E3RP3532	20	38	3
E3RP0782	21	29	5
E3RP2434	22	38	17
E3RP0744	31	36	3
E3RP0745	36	44	3
E3RP2341	44.5	83	3.2

DIMENSIONS

FLANGED WASHERS

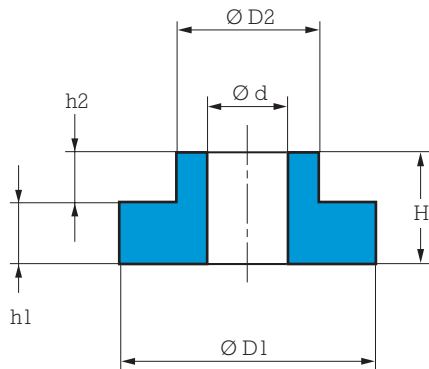

Reference	Ø d mm	Ø D1 mm	Ø D2 mm	H mm	h1 mm	h2 mm
E3RP0712	3.5	10	7.5	4.7	3.2	1.5
E3RP2292	3.5	13	6	7	3.3	3.7
E3RP3290	4	9	6	5.4	3.4	2
E3RP0647	4.2	8	5.8	3.3	1.7	1.6
E3RP0997	5	18	10	24	14	10
E3RP2192	6	12	8.5	7	4	3
E3RP2410	6	18	10	10	6	4
E3RP3533	6.5	15	11	8	4.5	3.5
E3RP0755	7	30	17	14	6	8
E3RP2374	8	18	12	6	3	3
E3RP2379	8	18	13	3.5	2	1.5
E3RP0563	8	19.8	13.8	7	2	5
E3RP2173	8	21	13	6	4	2
E3RP0778	8	24	14	8	4	4
E3RP2042	8.5	26	17	8	4	4
E3RP3491	9.5	24	18	8	4	4
E3RP3490	10	18	14	8	4	4
E3RP0553	11	24	17	9	4	5
E3RP0575	12	50	28	22	12	10
E3RP2315	16	50	28	22	12	10

GROMMETS

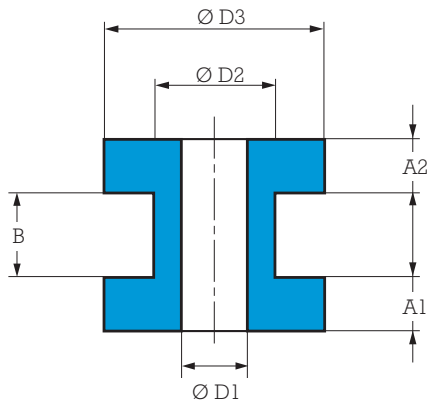

Reference	Ø D1 mm	Ø D2 mm	Ø D3 mm	A1 mm	A2 mm	B mm
E3RP2364	4	6	8	2.2	2.2	1.6
E3RP0648	4.2	5.8	8	1.7	1.7	1.6
E3RP0576	5	8	12	2	2	4
E3RP3295	8	12	18	5.5	5.5	3
E3RP3258	8	12	18	5.5	5.5	6

THREADED STUDS

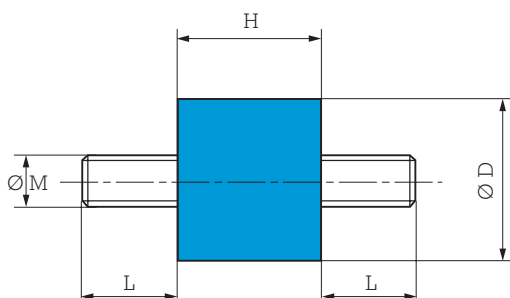

Reference	Ø D mm	H mm	L mm	Ø M
E3RP0953	10	8	6	M3
E3RP0956	12	8	6	M3
E3RP2118	16	16	8/9.5	M5
E3RP0757	20	23	12	M5
E3RP0954	33	26	13.2	M6
E3RP0708	33	39	13.2	M6
E3RP0686	33.2	53.5	12	M6

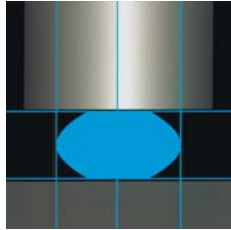

ELASTOMER PLATES E3PEPL

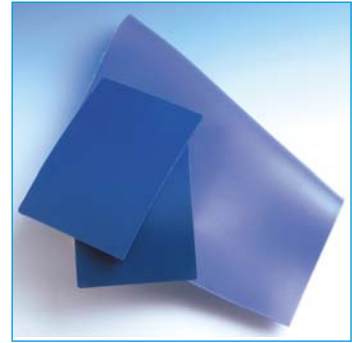

SILICONE RUBBER / SPECIAL ELECTRONICS

DESCRIPTION

VHDS elastomer sheet.

APPLICATIONS

These sheets may be used for making grommets, washers or anti-vibration mountings for equipment.
There is a wide range of VIBRACHOC moulded parts, but in certain cases, such as prototypes - undefined specification, etc, it is often advantageous to determine the suspension using elastomer components cut from sheet and bonded.

CHARACTERISTICS

- Overall tolerances:
 - on the lengths: $\pm 5\%$
 - on the thickness: $\pm 3\%$

SHAPE	DIMENSIONS mm	THICKNESS mm
SQUARE	300 X 300	2, 3, 4, 5, 6, 8, 10

VIBRACHOC plates should be ordered using the following reference:

E3PEPL □ □ S □ □ C □ □ □

└─┘ └─┘ └─┘
1 2 3

- 1: dimension in cm.
2: grade (see. table page 126).
3: thickness in 1/10 mm.

For example: E3PEPL30S55C060 =

- square plate 300 X 300 mm.
- 6 mm thick VHDS rubber compound.
- grade 55.

For other shapes, sizes or materials, ask us for details.



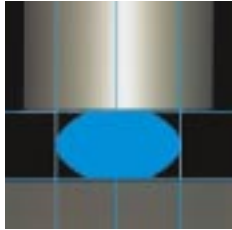

E1E11SE***
E1E12SE***
E1E13SE***



Natural frequency :
20 to 25 Hz

SILICONE RUBBER / SPECIAL ELECTRONICS

DESCRIPTION

- VHDS elastomer able to carry loads under compression and traction.
- pedestal, washer and shaft in stainless steel.

APPLICATIONS

- protecting electronic equipment, navigation equipment, instrument panels, measuring instruments, control panels on aircraft, road vehicles and railway trains.

CHARACTERISTICS

Natural frequency :

- axial : 20 to 25 Hz
- radial : 20 to 25 Hz.

Maximum permitted excitation at natural frequency of suspension : ± 0.5 mm.

Amplification factor at resonance < 5 .

Operating temperature : -54°C to $+150^{\circ}\text{C}$.

Structural strength corresponds to a continuous acceleration of 10 g at maximum load.

Maximum axial travel available for shock :

E1E11 : + 4mm / E1E12 : + 5 mm / E1E13 : + 7 mm.

Weight : E1E11 : 60 g / E1E12 : 120 g / E1E13 : 225 g.

Reference	Axial static loads in daN
E1E11S38EC	1.60 - 2.80
E1E11S42EC	1.80 - 3.20
E1E11S48EC	2.10 - 3.80
E1E11S55EC	2.50 - 4.50
E1E11S63EC	3.00 - 5.30
E1E11S72EC	3.50 - 6.20
E1E12S38ED	3.70 - 5.70
E1E12S42ED	4.00 - 6.30
E1E12S48ED	4.60 - 7.10
E1E12S55ED	5.20 - 8.10
E1E12S63ED	6.00 - 9.30
E1E12S72ED	6.60 - 10.30
E1E13S38EE	5.50 - 8.50
E1E13S42EE	6.00 - 9.50
E1E13S48EE	6.50 - 10.50
E1E13S55EE	7.50 - 12.00
E1E13S63EE	8.50 - 14.00
E1E13S72EE	10.00 - 16.00

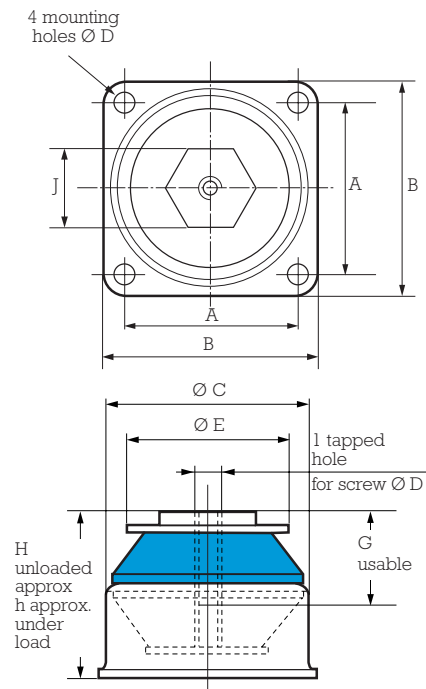

Reference	A mm	B mm	Ø C mm	Ø D mm	Ø E mm	H mm	J mm	Ø d mm	h mm	G mm
E1E11S □□ EC	25.4	34	28.5	M5	23	29	14	4.3	28	10
E1E12S □□ ED	34.9	44.4	40	M6	34.6	35.6	19	4.3	34.5	12
E1E13S □□ EE	49.2	60.5	57	M8	45	47	23	5.3	45.5	16



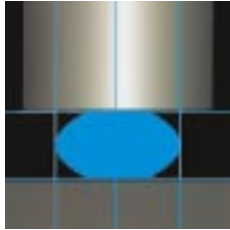

E1E11SAL***
E1E12SAL***
E1E13SAL***



Natural frequency :
 20 to 25 Hz

SILICONE RUBBER / SPECIAL ELECTRONICS

DESCRIPTION

- VHDS elastomer able to carry loads under compression and traction.
- flange, washer and shaft in steel.

APPLICATIONS

- protecting electronic equipment, navigation equipment, instrument panels, measuring instruments, control panels on aircraft, road vehicles and railway trains.

CHARACTERISTICS

Natural frequency :

- axial : 20 to 25 Hz
- radial : 20 to 25 Hz.

Maximum permitted excitation at natural frequency of suspension : ± 0.5 mm.

Amplification factor at resonance < 5 .

Operating temperature : $- 54^{\circ}\text{C}$ to $+ 150^{\circ}\text{C}$.

Structural strength corresponds to a continuous acceleration of 10 g at maximum load.

Maximum axial travel available for shocks :

E1E11 : + 4mm / E1E12 : + 5 mm / E1E13 : + 7 mm.

Weight : E1E11 : 25 g / E1E12 : 75 g / E1E13 : 225 g.

4 mounting holes
 for screw $\varnothing d$

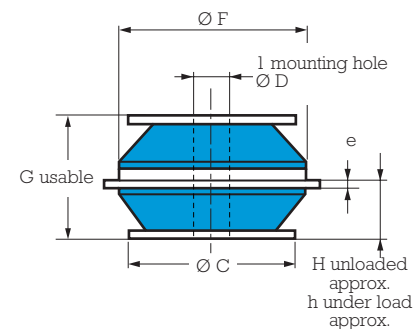
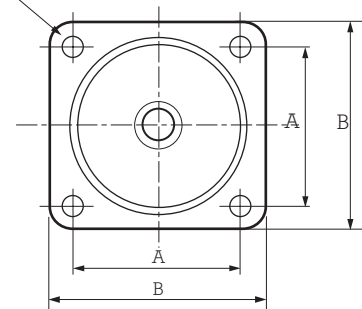

Reference	Axial static loads in daN
E1E11S38AL	1.60 - 2.80
E1E11S42AL	1.80 - 3.20
E1E11S48AL	2.10 - 3.80
E1E11S55AL	2.50 - 4.50
E1E11S63AL	3.00 - 5.30
E1E11S72AL	3.50 - 6.20
E1E12S38AL	3.70 - 5.70
E1E12S42AL	4.00 - 6.30
E1E12S48AL	4.60 - 7.10
E1E12S55AL	5.20 - 8.10
E1E12S63AL	6.00 - 9.30
E1E12S72AL	6.60 - 10.30
E1E13S38AL	5.50 - 8.50
E1E13S42AL	6.00 - 9.50
E1E13S48AL	6.50 - 10.50
E1E13S55AL	7.50 - 12.00
E1E13S63AL	8.50 - 14.00
E1E13S72AL	10.00 - 16.00

Reference	A mm	B mm	Ø C mm	Ø F mm	G mm	Ø d mm	e mm	H mm	h mm	Ø D mm
E1E11S □□ AL	25.4	32	23	25.4	19	3.6	1.5	10	9	5.2
E1E12S □□ AL	34.9	44.5	34.6	38.7	25.4	4.2	1.8	11.5	10.5	6.7
E1E13S □□ AL	49.2	80.5	45	53	38	5.3	2.5	17.75	16.5	8.3



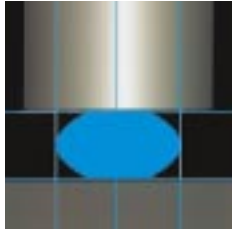

E1E21
E1E22
E1E23



Natural frequency :
20 to 25 Hz

SILICONE RUBBER / SPECIAL ELECTRONICS

DESCRIPTION

- VHDS elastomer.
 - flange and shaft in 18/8 stainless steel.
- Two Ø K fail safe rings must be provided.

APPLICATIONS

- protecting electronic equipment, navigation equipment, instrument panels, measuring instruments, control panels on aircraft, road vehicles and railway trains.

CHARACTERISTICS

Natural frequency :

- axial : 15 to 25 Hz
- radial : 20 to 35 Hz.

Maximum permitted excitation at natural frequency of suspension : ± 0.5 mm.

Amplification factor at resonance < 4.

Operating temperature : - 54°C to + 150°C.

Structural strength corresponds to a continuous acceleration of 10 g at maximum load.

Maximum axial travel available for shock :

E1E21 : ± 4 mm for f min / E1E22 : ± 4.5 mm for f min
 ± 6 mm for f max ± 6 mm for f max.

Weight : E1E21 : 9 g / E1E22 : 25 g / E1E23 : 63 g.

Reference	A mm	B mm	Ø C mm	Ø D	E mm	Ø d mm	e mm	H mm	h mm
E1E21S □□ AL	25.4	32	24	M4	19	3	0.8	12.5	11
E1E22S □□ AL	34.9	44.5	28	M5	25.4	4	1.5	16.5	15
E1E23S □□ AL	49.2	60.5	42	M6	36	5	2	22	20

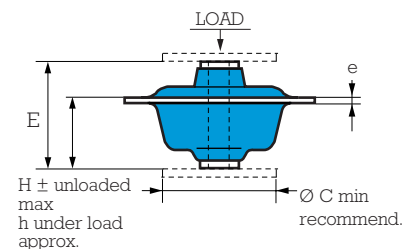
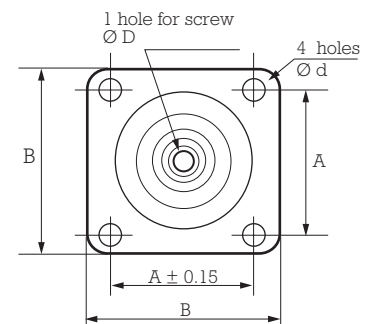

Reference	Axial static loads in daN	Frequency in Hz	Axial static loads in daN	Frequency in Hz
E1E21S38AL	0.15-0.40	15-20	0.10-0.15	20-25
E1E21S63AL	0.30-0.90		0.20-0.30	
E1E21S77AL	0.40-1.20		0.26-0.40	
E1E22S38AL	0.40-1.00	12-18	0.20-0.40	18-25
E1E22S63AL	0.70-1.70		0.40-0.70	
E1E22S77AL	0.90-2.20		0.50-0.90	
E1E23S42AL	0.40-1.20	10-15		
E1E23S77AL	1.00-2.90			

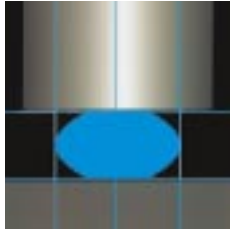

E1E31 E1E32

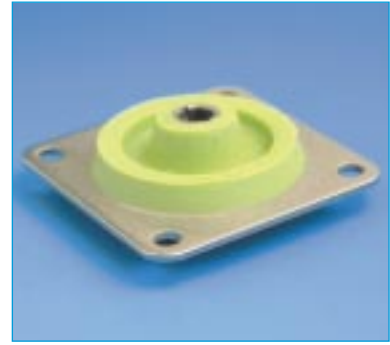

Natural frequency :
15 to 25 Hz

SILICONE RUBBER / SPECIAL ELECTRONICS

DESCRIPTION

- VHDS elastomer.
 - flange and shaft in 18/8 stainless steel.
- Two $\varnothing K$ fail safe rings must be provided.

APPLICATIONS

- protecting electronic equipment, navigation equipment, instrument panels, measuring instruments, control panels on aircraft, road vehicles and railway trains.

CHARACTERISTICS

Natural frequency :

- axial : 15 to 25 Hz
- radial : 20 to 35 Hz.

Maximum permitted excitation at natural frequency of suspension : ± 0.5 mm.

Amplification factor at resonance < 4 .

Operating temperature : $- 54^{\circ}\text{C}$ to $+ 150^{\circ}\text{C}$.

Structural strength corresponds to a continuous acceleration of 10 g with maximum load.

Maximum axial travel available for shocks :

E1E 31 : ± 4 mm for f min
 ± 6 mm for f max.

E1E 32 : ± 4.5 mm for f min
 ± 6 mm for f max.

Weight : E1E31 : 9 g / E1E32 : 25 g.

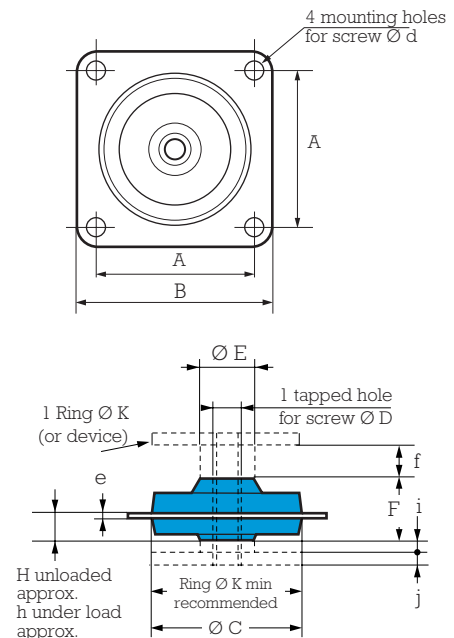

Reference	Axial static loads in daN	Frequency in Hz	Axial static loads in daN	Frequency in Hz
E1E31S38AL	0.20-0.70	15-20	0.20-0.40	20-25
E1E31S55AL	0.30-1.00		0.30-0.50	
E1E31S77AL	0.50-1.70		0.50-0.90	
E1E32S38AL	0.30-1.10	15-20	0.30-0.70	20-25
E1E32S55AL	0.60-1.80		0.60-1.10	
E1E32S77AL	0.80-2.60		0.80-1.60	

Reference	A mm	B mm	$\varnothing C$ mm	$\varnothing D$	$\varnothing E$ mm	F mm	J mm	K mm	d mm	e mm	f (mm)		H mm	j (mm)		h mm
											Min	Max		Min	Max	
E1E31S \square AL	25.4	32	25	M4	8.5	10.5	2	25	3.6	1	3.2	5	4.5	0	1.75	3.5
E1E32S \square AL	34.9	44.5	35	M5	13	14.5	3	35	4.3	1.5	4.5	7	6.2	0	2.5	5



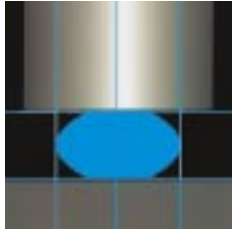

E1E41
E1E42
E1E43



Natural frequency :
10 to 25 Hz

SILICONE RUBBER / SPECIAL ELECTRONICS

DESCRIPTION

- VHDS elastomer able to carry loads under compression.
- base and centre axis in stainless steel.

APPLICATIONS

- protecting electronic equipment, navigation equipment, instrument panels, measuring instruments, control panels on aircraft, road vehicles and railway trains.

CHARACTERISTICS

Natural frequency :

- axial and radial : 10 to 25 Hz.

Maximum permitted excitation at natural frequency of suspension : ± 0.5 mm.

Amplification factor at resonance < 4 .

Operating temperature : $- 54^{\circ}\text{C}$ to $+ 150^{\circ}\text{C}$.

Structural strength corresponds to a continuous acceleration of 10 g at maximum load.

Maximum axial travel available for shocks :

E1E41 : 8.8 mm / E1E42, E1E43 : 12 mm.

Weight : E1E41 : 22 g / E1E42 : 60 g / E1E43 : 96 g.

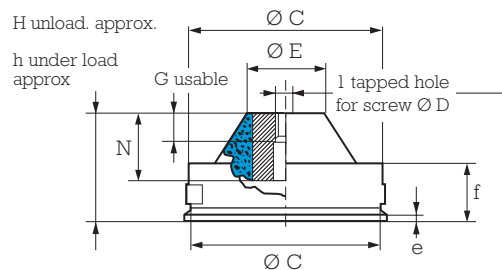
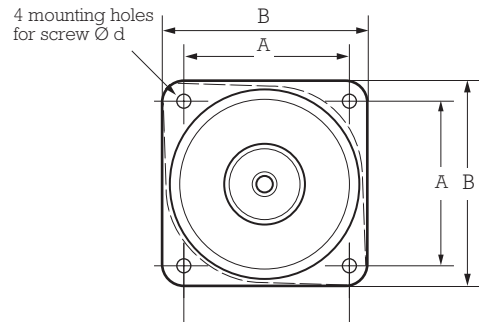

Reference	Axial static loads in daN
E1E41-S38EB	1.20-2.10
① E1E41-S63EB	2.00-3.80
E1E41-S77EB	3.00-5.20
E1E42-S38EC	1.75-3.30
E1E42-S63EC	3.20-5.90
E1E42-S77EC	4.40-8.30
E1E43-S38ED	3.10-5.50
E1E43-S63ED	5.40-10.80
E1E43-S77ED	7.50-13.60

① These isolators exist with an oval flange (FB).

Reference	A mm	B mm	Ø C mm	Ø D	Ø E mm	G mm	H mm	N mm	d mm	e mm	f mm	h mm
E1E41-□□EB	25.4	34	30.5	M4	10	6	23	14.2	4.3	0.8	14	21
E1E42-□□EC	34.9	43	41.5	M5	12	8	33	20	4.3	1.5	18	31
E1E43-□□ED	49.2	60.5	57	M6	21.5	8	33	20	5.3	2	16	31



ALPHANUMERIC INDEX - VIBRACHOC RANGE

Reference	Designation	Page	Reference	Designation	Page	Reference	Designation	Page
E1C2321S01	Special packaging	123	E1E13S72EE	Special electronics	129	E1N104C75	VIBMAR	117
E1C2321S02	Special packaging	123	E1E21S38AL	Special electronics	131	E1N106C60	VIBMAR	117
E1C2321-01	Special packaging	123	E1E21S63AL	Special electronics	131	E1N106C75	VIBMAR	117
E1C2321-02	Special packaging	123	E1E21S77AL	Special electronics	131	E1N2296-01	VIBMAR	115
E1C2321-03	Special packaging	123	E1E22S38AL	Special electronics	131	E1N2296-02	VIBMAR	115
E1C2321-21	Special packaging	123	E1E22S63AL	Special electronics	131	E1N2296-03	VIBMAR	115
E1C2321-22	Special packaging	123	E1E22S77AL	Special electronics	131	E1N2296S01	VIBMAR	115
E1C2321-23	Special packaging	123	E1E23S42AL	Special electronics	131	E1N2296S02	VIBMAR	115
E1E1S38AL	Special electronics	130	E1E23S77AL	Special electronics	131	E1N2296S03	VIBMAR	115
E1E11S42AL	Special electronics	130	E1E31S38AL	Special electronics	132	E1M-3950-01	'X' Type	118
E1E11S48AL	Special electronics	130	E1E31S55AL	Special electronics	132	E1M-3951-01	'X' Type	118
E1E11S55AL	Special electronics	130	E1E31S77AL	Special electronics	132	E1M-3952-01	'X' Type	118
E1E11S63AL	Special electronics	130	E1E32S38AL	Special electronics	132	E1M-3953-01	'X' Type	118
E1E11S72AL	Special electronics	130	E1E32S55AL	Special electronics	132	E1M-3954-01	'X' Type	118
E1E12S38AL	Special electronics	130	E1E32S77AL	Special electronics	132	E1M-3955-01	'X' Type	118
E1E12S42AL	Special electronics	130	E1E41S38EB	Special electronics	133	E1M-3956-01	'X' Type	118
E1E12S48AL	Special electronics	130	E1E41S63EB	Special electronics	133	E1M-3957-01	'X' Type	118
E1E12S55AL	Special electronics	130	E1E41S77EB	Special electronics	133	E1M-3958-01	'X' Type	118
E1E12S63AL	Special electronics	130	E1E42S38EC	Special electronics	133	E1T2105S01	Special packaging	124
E1E12S72AL	Special electronics	130	E1E42S63EC	Special electronics	133	E1T2105S02	Special packaging	124
E1E13S38AL	Special electronics	130	E1E42S77EC	Special electronics	133	E1T2105-21	Special packaging	124
E1E13S42AL	Special electronics	130	E1E43S38ED	Special electronics	133	E1T2105-22	Special packaging	124
E1E13S48AL	Special electronics	130	E1E43S63ED	Special electronics	133	E1T2105-23	Special packaging	124
E1E13S55AL	Special electronics	130	E1E43S77ED	Special electronics	133	E1T2105-41	Special packaging	124
E1E13S63AL	Special electronics	130	E1FH76-01	ARDAMP	119	E1T2105-42	Special packaging	124
E1E13S72AL	Special electronics	130	E1FH76-02	ARDAMP	119	E1T2105-43	Special packaging	124
E1E11S38EC	Special electronics	129	E1FH77-01	ARDAMP	119	E1V-3245-04	Bump stop	88
E1E11S42EC	Special electronics	129	E1FH78-01	ARDAMP	119	E1V-3568-01	Bump stop	88
E1E11S48EC	Special electronics	129	E1FH78-02	ARDAMP	119	E1V-3892-01	Bump stop	88
E1E11S55EC	Special electronics	129	E1FH781C01	ARDAMP	119	E1V-3914-01	Bump stop	88
E1E11S63EC	Special electronics	129	E1FH781S01	ARDAMP	119	E1V-3921-01	Bump stop	88
E1E11S72EC	Special electronics	129	E1FH866C01	ARDAMP	119	E1V-3922-01	Bump stop	88
E1E12S38ED	Special electronics	129	E1FH2507-01	ARDAMP	119	E1V-3927-01	Bump stop	88
E1E12S42ED	Special electronics	129	E1N101-01	VIBMAR	116	E1V-3931-01	Bump stop	88
E1E12S48ED	Special electronics	129	E1N101-02	VIBMAR	116	E1V-3932-01	Bump stop	88
E1E12S55ED	Special electronics	129	E1N101-04	VIBMAR	116	E1V-3940-01	Bump stop	88
E1E12S63ED	Special electronics	129	E1N101-05	VIBMAR	116	E1V-4031-01	Bump stop	88
E1E12S72ED	Special electronics	129	E1N101-06	VIBMAR	116	E1V-4059-11	Bump stop	88
E1E13S38EE	Special electronics	129	E1N104C45	VIBMAR	117	E3RP..	Special electronics	126-127
E1E13S42EE	Special electronics	129	E1N104C60	VIBMAR	117	E3PEPL...	Special electronics	128
E1E13S48EE	Special electronics	129				E4330-F11	Mounting	96
E1E13S55EE	Special electronics	129						
E1E13S63EE	Special electronics	129						

PAULSTRA



ELASTOMER RANGE BARRY CONTROLS



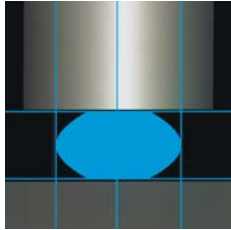

PNEUMATIC MOUNTS SLM



(1) Natural frequency:
3 to 5 Hz

DESCRIPTION

SLM pneumatic mounts are made from synthetic rubber and are laterally reinforced with steel springs.

The base plate is bored with 4 smooth holes to allow a possible fixing on the ground and the valve allows to inflate the mount in the same way as an automobile tyre.

- Elastomer body (temperature range -30°C à $+180^{\circ}\text{C}$) resistant to oils, the majority of solvents and natural ageing.
- The top and bottom plates are available in both steel and aluminium.

OPERATION

The design of SLM mounts gives the following basics characteristics:

- In the event of loss of pressure, the machine will rest on the elastomer body. The load capacity of the mounting remains unchanged.
- The ratio of horizontal rigidity and vertical rigidity of the SLM is 1:1, which allows excellent stability.

Advantages:

- Eight sizes, capacity range of 10 daN to 10000 daN.
- Allow you to level the machine gradually while varying the air pressure.
- Possibility of varying the natural frequency, by varying the air pressure.

APPLICATIONS

- Industrial plant, compressors, conveyors, vacuum pumps, generators, air-conditioners, diesel engines, ventilators, presses with fast cycle, machine tools.
- Metrology: measuring apparatus sensitive to the external disturbances, optical instruments, etc.

(1) Natural frequencies with max/min loads, see : OPERATING CHARACTERISTICS.

DIMENSIONS AND OPERATING CHARACTERISTICS

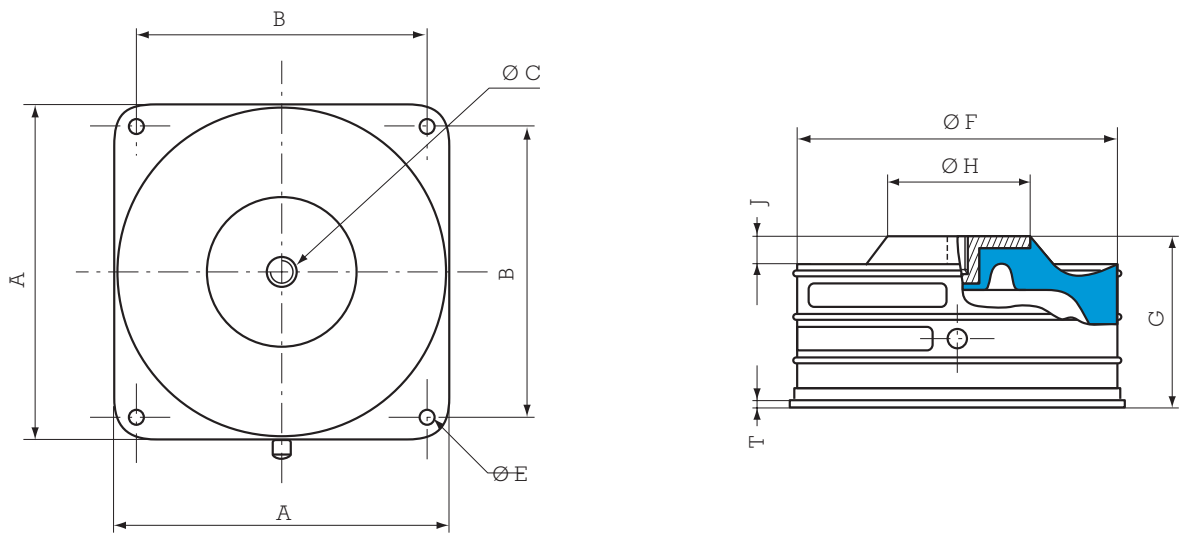

Paulstra reference	Barry Controls * reference	Nominal static load daN	A mm	B mm	Ø C	Ø E mm	Ø F mm	G mm	Ø H mm	J mm	T mm	Weig. kg
530904 01	SLM-M1A	11 - 45	76.2	60.4	M10	12	73.2	63.5	25.4	12.7	3.2	0.5
530904 02	SLM-M3A	34 - 136	106.4	88.9	M12	14	105.2	62.2	44.4	12.7	3.2	0.7
530904 03	SLM-M6A	68 - 272	130.0	108.0	M12	14	126.7	88.9	54.1	14.2	3.2	1.5
530904 04	SLM-M12A	136 - 545	174.8	152.4	M12	14	171.2	88.9	76.2	14.2	3.2	2.5
530904 05	SLM-M24A	272 - 1090	254.0	215.9	M16	19	245.4	88.9	138.2	14.2	4.8	6
530904 06	SLM-M48A	545 - 2180	342.9	304.8	M16	19	338.1	88.9	190.5	14.2	4.8	11.8
530904 07	SLM-M96A	1090 - 4360	469.9	406.4	M24	22	468.4	88.9	266.7	14.2	6.4	26.0
530904 08	SLM-M192A	2180 - 8720	609.6	508.0	M24	22	609.6	88.9	400.1	14.2	6.4	45.0

See current price list for availability of items.

1 kg ≈ 1 daN

* Barry Controls references are given as an indication.

PRESSURE OF INFLATION FOR STATIC HEAD AND NATURAL FREQUENCY

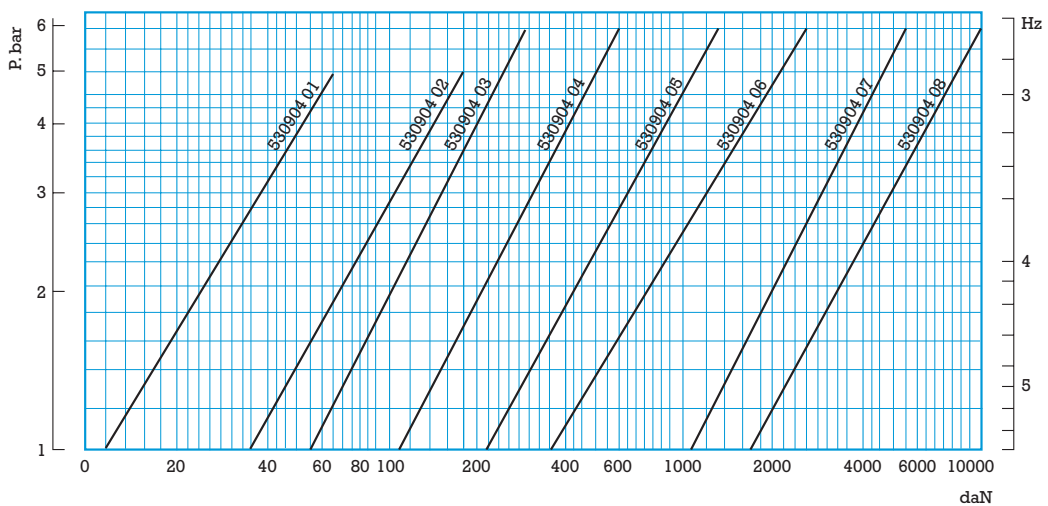

ASSEMBLY

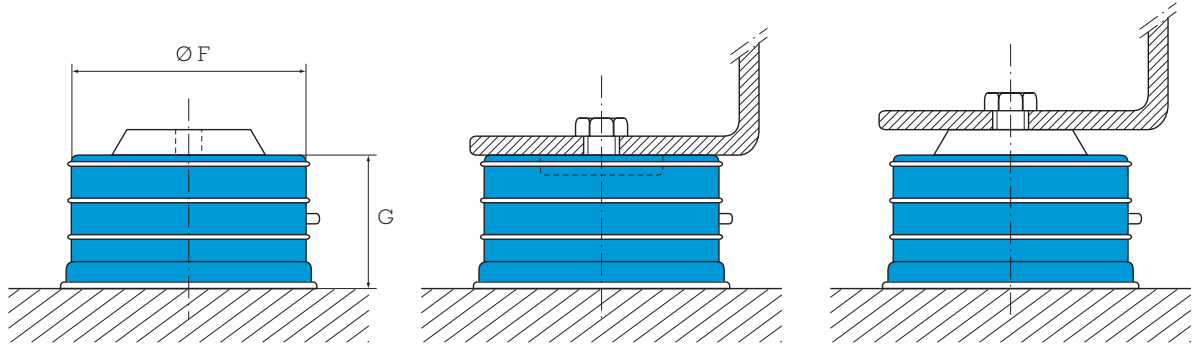

1 - AV mount

2 - Install the machinery

3 - Inflate the mount

Correct assembly

Recommendations:

- The machine must rest on the supports before they are inflated to the level indicated on dimension " G ".
- Before any disassembling, the SLM mount must be deflated.
- The surface of the machine must completely cover the surface ($\varnothing F$) of the mount. If it is not possible, use a separate plate (thickness between 5 and 10 mm, according to the load) and diameter equal to $F + 10$ mm. This is to obtain a base on the full surface. It is required for assembly and in the event of an air leakage.
- If necessary, it is possible to fix the supports using the four smooth holes on the bed plate.
- Make sure care that the valves are protected.
- Never overload the mounts. Always use the recommended load capabilities.

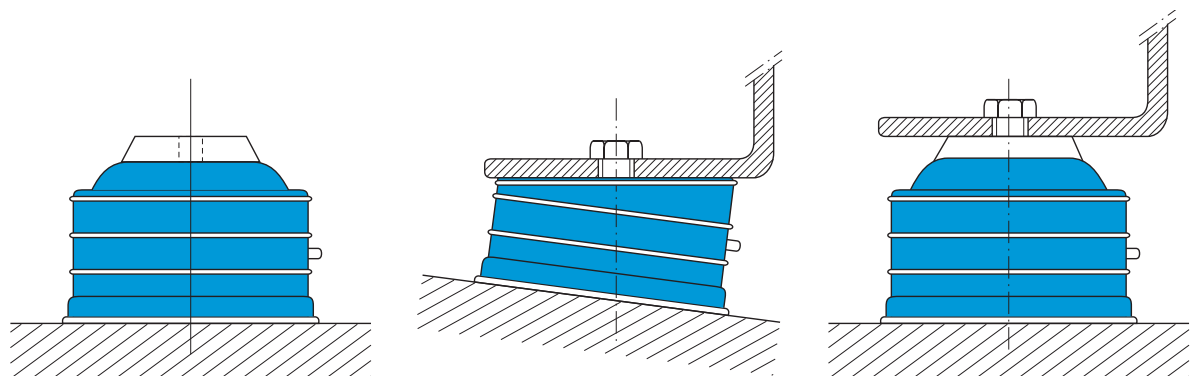

Mount inflated before fixing the machinery

Floor not level

Over inflated mount

Uncorrect assemblies

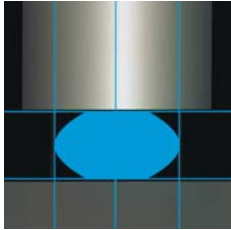

22000 MOUNT



(1) Natural frequency:
8 to 18 Hz

DESCRIPTION

The 22000 mount is made of two parts of elastomer bonded to a central tube.

- Interior reinforced: cylindrical tube.
- Elastomer: chloroprene. Range of five different stiffnesses.

OPERATION

The design of the 22000 mount gives the following basic characteristics.

- Elastomer element resistant to oils, supporting axial and radial loadings.
- Axial to radial stiffness of 1 : 1.
- Absorb vibrations and reduce noise in all directions.

Advantages :

- Good isolation against structural noises.
- Chloroprene resistant to oils.
- Simple and economical.
- Simple to fix.
- Five sizes for a load capacity under axial pressure from 15 to 2100 kg and under radial pressure until 650 kg.
- Anti-rebound effect when it is assembled with a washer.

APPLICATIONS

22000 mounts can be used in static or mobile applications, such as: pumps, compressors, generators, electronic equipment, HVAC equipment, engines with internal combustion, transmissions, plant cabs, radiators, etc.

(1) Natural frequencies with max/min loads, see : OPERATING CHARACTERISTICS.

DIMENSIONS CHARACTERISTICS

C1: \varnothing mounting hole
 C2: \varnothing elastomer
 F: Free height
 R: Radius required

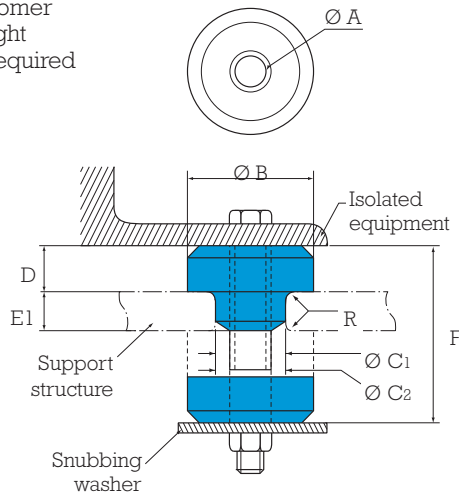

E1 type assembly

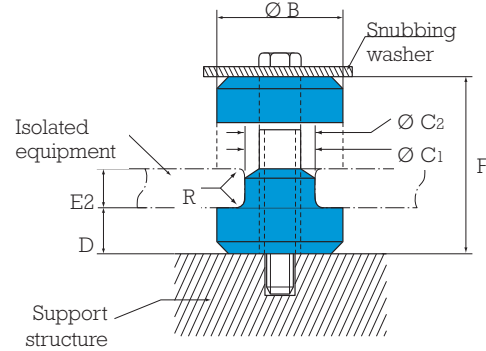

E2 type assembly

Paulstra reference	Barry Controls* reference	$\varnothing A$ mm	$\varnothing B$ mm	$\varnothing C1$ mm	$\varnothing C2$ mm	D mm	E1 mm	E2 mm	F mm	R mm	Weight g
530903 11 / 15	22001-11 / 15	10.4	33.2	19	20.1	12.3	9.5	9.5	31.7	1	43
530903 21 / 25	22002-11 / 15	13.5	47.7	31.7	33	19.8	14	12.5	49.2	1.5	142
530903 31 / 35	22003-11 / 15	16.7	64.8	38.1	40.1	22.8	22	19	61.7	2.3	313
530903 41 / 45	22004-11 / 15	23.8	88.9	57.1	58.4	25.4	28.5	25.5	73.1	3	670
530903 51 / 55	22005-11 / 15	27	123.9	63.5	64.8	31.7	32	25.5	85.8	3	1306

See current price list for availability of items.

1 kg \approx 1 daN

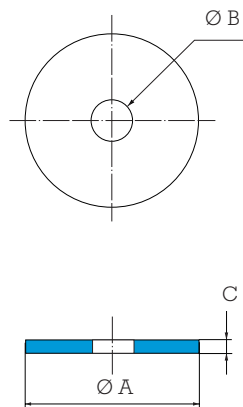

Washers are recommended for the assembly of the mount. They make it possible to carry out debouncing.

PAULSTRA Reference*	Washer			
	$\varnothing A$ mm	$\varnothing B$ mm	C mm	Weight g
530903 11 / 15	39.6	10.3	2.2	24
530903 21 / 25	54.1	13.5	3.4	54
530903 31 / 35	71.3	16.7	4.7	140
530903 41 / 45	98.5	23.8	6.3	368
530903 51 / 55	133.3	27.0	9.5	991

* References given as an indication.

OPERATING CHARACTERISTICS

The maximum loadings depend on the compression of the assembly by comparing the thicknesses E1 and E2.

Paulstra reference	Barry Controls* reference	Support structure E1 Load per mount				Support structure E2 Load per mount			
		Axial daN	Radial daN	Fo Hz	E1 mm	Axial daN	Radial daN	Fo Hz	E2 mm
530903 11	22001-11	18	9			18	9		
530903 12	22001-12	40	13			40	13		
530903 13	22001-13	63	18	15	9.5	63	18	15	9.5
530903 14	22001-14	113	22			113	22		
530903 15	22001-15	136	27			136	27		
530903 21	22002-11	59	22			27	18		
530903 22	22002-12	79	29			54	36		
530903 23	22002-13	109	40	12	14	72	56	15	12.5
530903 24	22002-14	172	75			118	81		
530903 25	22002-15	286	127			172	127		
530903 31	22003-11	95	40			40	31		
530903 32	22003-12	159	63			68	47		
530903 33	22003-13	222	102	11	22	102	72	15	25.5
530903 34	22003-14	390	175			147	111		
530903 35	22003-15	604	313			227	163		
530903 41	22004-11	122	61			68	50		
530903 42	22004-12	231	104			136	100		
530903 43	22004-13	350	156	10	28.5	181	136	15	25.5
530903 44	22004-14	531	268			227	181		
530903 45	22004-15	954	443			272	263		
530903 51	22005-11	518	109			136	68		
530903 52	22005-12	877	154			227	100		
530903 53	22005-13	1172	277	10	32	318	136	15	25.5
530903 54	22005-14	1609	404			409	213		
530903 55	22005-15	2072	640			545	300		

See current price list for availability of items.

1 kg \approx 1 daN

LOAD/DEFLECTION CURVES IN AXIAL COMPRESSION

Assembly type E1 and E2

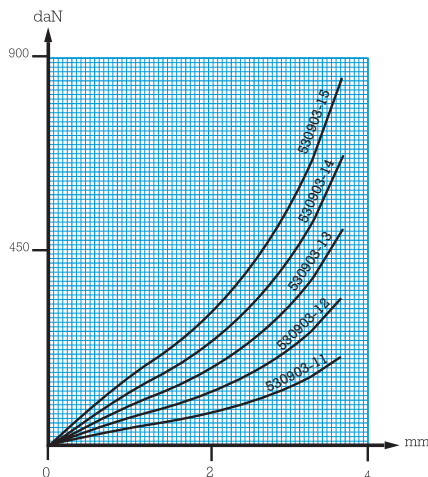

Assembly type E1

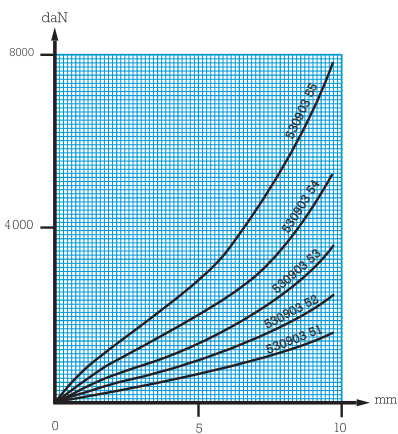
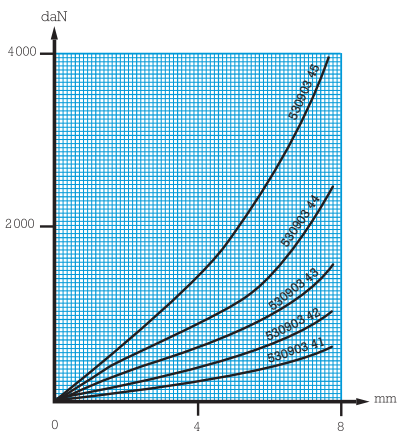
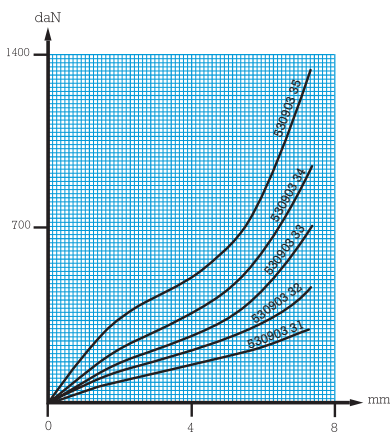
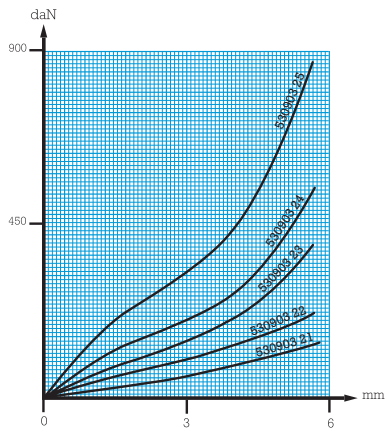

Assembly type E2

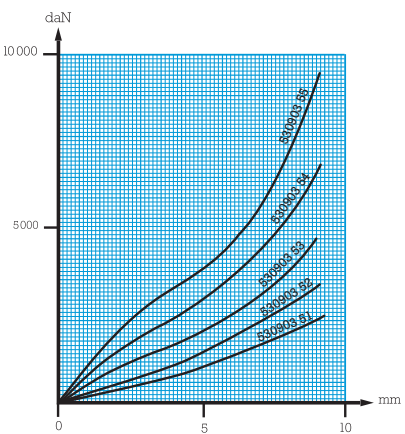
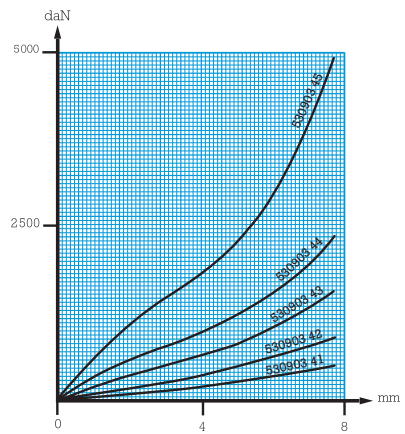
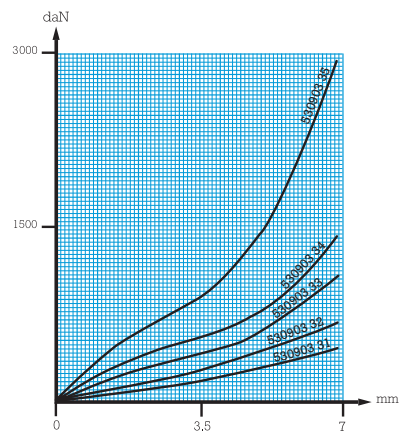
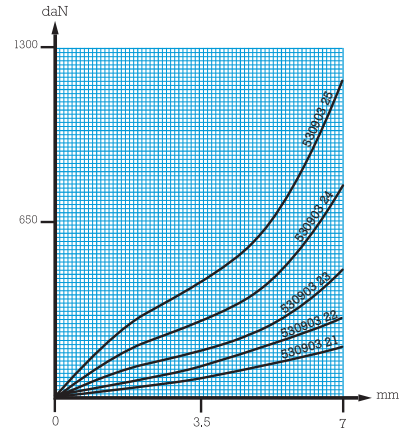

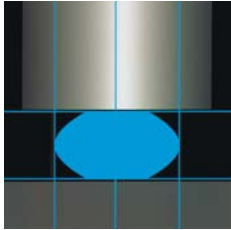

CUPMOUNT



(1) Natural frequency:
25 to 35 Hz

DESCRIPTION

The CUPMOUNT is made of rubber bonded to two metal reinforcements of truncated form.

- Interior reinforcement with tapped hole.
- External reinforcements with square base (4 holes).

OPERATION

The design of the CUPMOUNT gives the following basic characteristics:

- The ratio of radial and axial rigidity of the elements is 1/1, which allows excellent stability.

Advantages:

- Four models, load capacity of 1 to 1000 daN.
- Support iso-stiffness into axial and radial.
- Can be assembled multidirectional. Effective in compression, traction and shear
- Chloroprene resistant to oils.
- Easy and fast to install.

APPLICATIONS

Engines, pumps, air conditioning, ventilators, transformers...

The CUPMOUNT can also be used for suspended ceilings and for mobile applications

(1) Natural frequencies with max/min loads, see : OPERATING CHARACTERISTICS.

DIMENSIONS CHARACTERISTICS

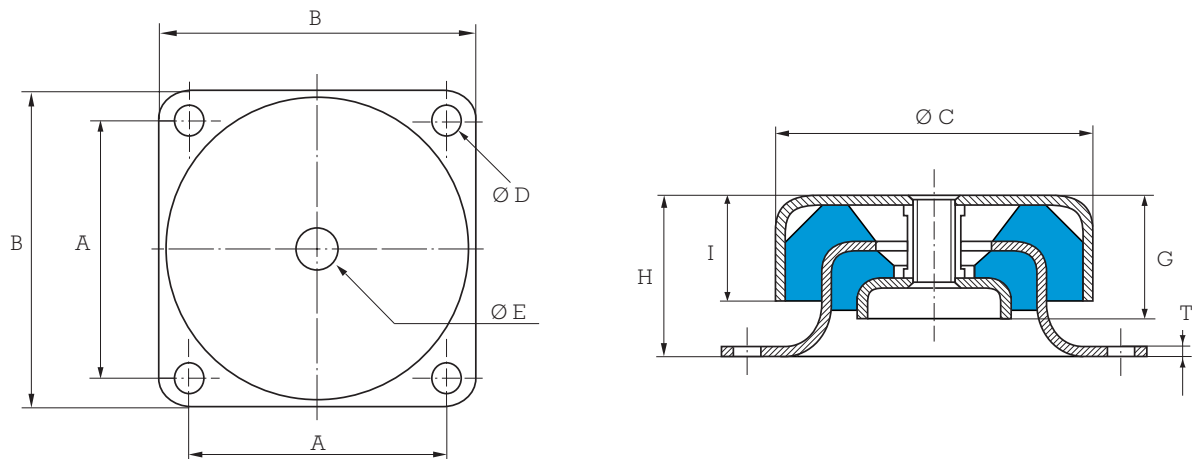

Reference 530906

Paulstra reference	Barry Controls* reference	A mm	B mm	Ø C mm	Ø D mm	Ø E mm	G mm	H mm	I mm	T mm	Weight gr
530906 11/14	C1000	49.5	60	58	5.2	M6	20	28	18	1.6	0.2
530906 21/26	C2000	63.5	75	76	6.4	M10	30	38	25	2.3	0.4
530906 31/34	C3000	143	175	168	13.5	M16	65	90	59	4.7	4.5
530906 41/44	C4000	108	133	124	11.9	M16	19	63	38	4	1.8

* Barry Controls references are given as an indication.

OPERATING CHARACTERISTICS

Paulstra reference	Barry Controls* reference	Maximum load daN	
		Mobile application	Static application
530906 11	C1010	6.5	6.5
530906 12	C1015	14	14
530906 13	C1035	26	26
530906 14	C1050	45	45
530906 21	C2020	13	26
530906 22	C2040	24	48
530906 23	C2060	34	68
530906 24	C2075	60	120
530906 25	C2090	72	144
530906 26	C2125	92	184
530906 41	C4100	70	140
530906 42	C4135	118	236
530906 43	C4200	160	320
530906 44	C4300	250	500
530906 31	C3125	90	180
530906 32	C3175	125	250
530906 33	C3300	165	330
530906 34	C3500	330	660

* Barry Controls references are given as an indication.

1 kg ≈ 1 daN

LOAD/DEFLECTION CURVES IN AXIAL COMPRESSION

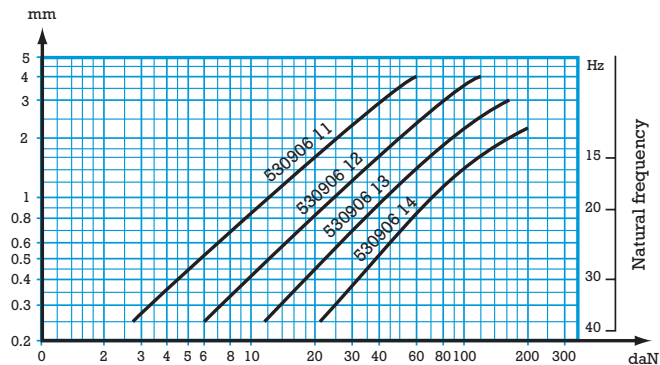

Reference 530906 11/14

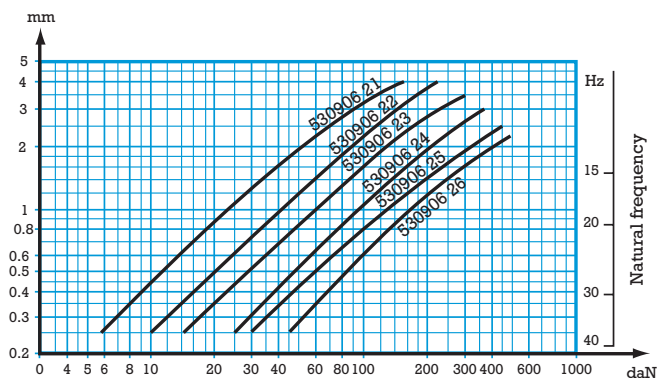

Reference 530906 21/26

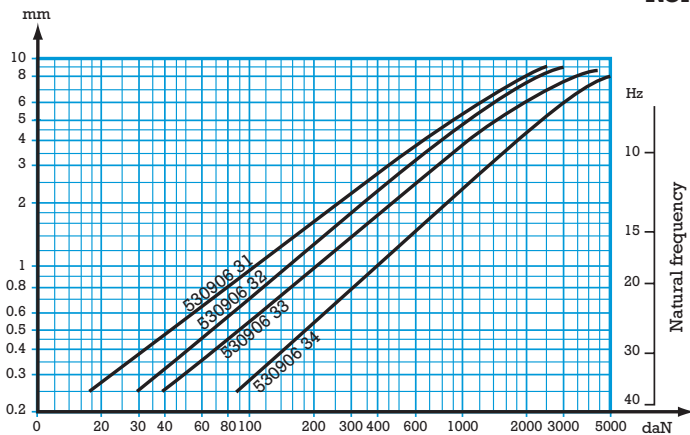

Reference 530906 31/34

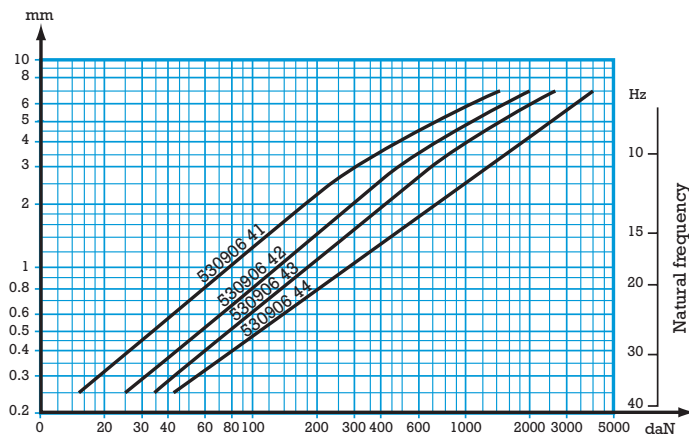

Reference 530906 41/44

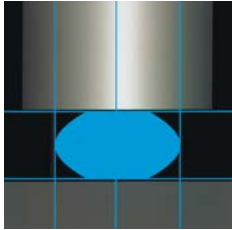

RINGS AND BUSHINGS



(1) Natural frequency:
6 to 28 Hz

DESCRIPTION

All elements made of elastomer.
Elastomer is compatible with the majority of the industrial environments and has an operating temperature range of -40°C to $+83^{\circ}\text{C}$

OPERATION

A ring assembled with the associated bushing constitutes a flexible interface and a simple solution to decrease noise and vibrations.

- These supports can be installed in parallel for a greater load capacity and may also be stacked in series when greater deflection capacity is required.

Advantages:

- Highly efficient noise reduction.
- Absorb shock and vibrations.
- Simple and economic.
- Four models in four stiffnesses for load capacities going from 0.5 to 160 kg per isolator.

APPLICATIONS

- Office machines, motors, fans, HVAC equipment, electronics equipment, telecommunication equipment.

(1) Natural frequencies with max/min loads, see : OPERATING CHARACTERISTICS.

DIMENSIONS CHARACTERISTICS

Rings

Bushings

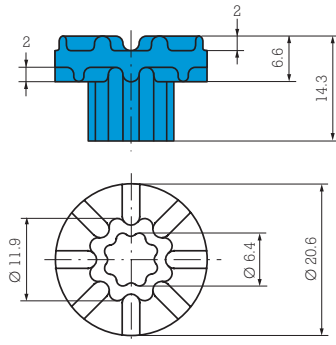

Fig. 1

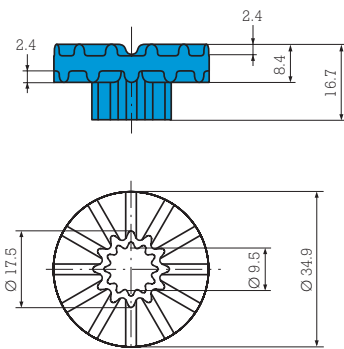
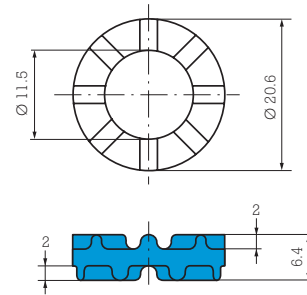

Fig. 2

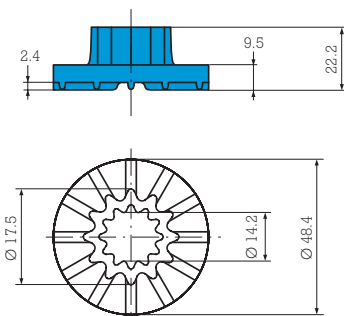
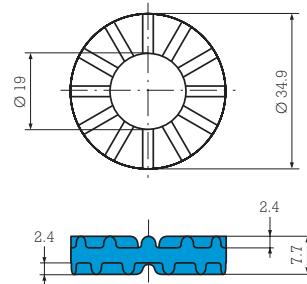

Fig. 3

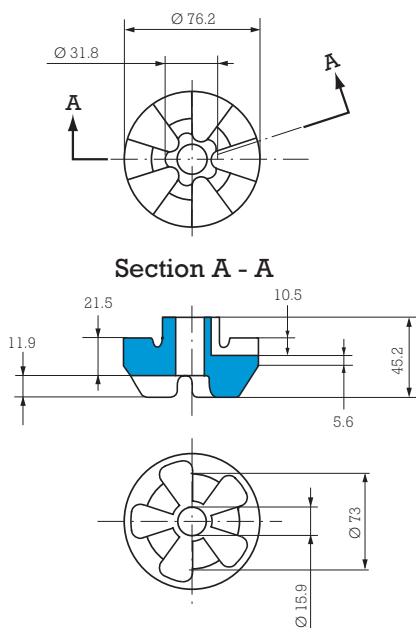
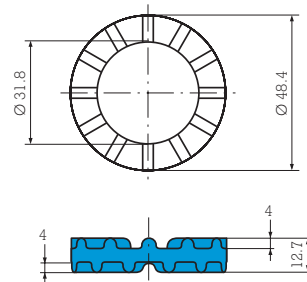
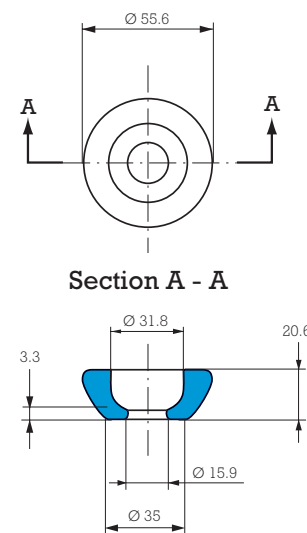

Fig. 4



OPERATING CHARACTERISTICS

Group Paulstra reference Barry Controls reference *	Fig	Load range	
		Min. (daN)	Max. (daN)
530907 13 / 530908 13 <i>WR1-030 / WB1-030</i>	1	0.4	1.8
530907 14 / 530908 14 <i>WR1-040 / WB1-040</i>	1	0.9	2.7
530907 15 / 530908 15 <i>WR1-050 / WB1-050</i>	1	1.4	3.6
530907 16 / 530908 16 <i>WR1-060 / WB1-060</i>	1	2.3	5.4
530907 43 / 530908 43 <i>WR4-030 / WB4-030</i>	3	2.7	9
530907 44 / 530908 44 <i>WR4-040 / WB4-040</i>	3	3.2	10.5
530907 45 / 530908 45 <i>WR4-050 / WB4-050</i>	3	4.5	11.4
530907 46 / 530908 46 <i>WR4-060 / WB4-060</i>	3	6.8	16

Group Paulstra reference Barry Controls reference *	Fig	Load range	
		Min. (daN)	Max. (daN)
530907 33 / 530908 33 <i>WR3-030 / WB3-030</i>	2	4.7	16
530907 34 / 530908 34 <i>WR3-040 / WB3-040</i>	2	9	23
530907 35 / 530908 35 <i>WR3-050 / WB3-050</i>	2	13.6	27
530907 36 / 530908 36 <i>WR3-060 / WB3-060</i>	2	18	74
530907 63 / 530908 63 <i>WR6-030 / WB6-030</i>	4	27	55
530907 64 / 530908 64 <i>WR6-040 / WB6-040</i>	4	50	73
530907 65 / 530908 65 <i>WR6-050 / WB6-050</i>	4	61	114
530907 66 / 530908 66 <i>WR6-060 / WB6-060</i>	4	73	159

* Barry Controls references are given as an indication.

1 kg ≈ 1 daN

LOAD/DEFLECTION CURVES IN AXIAL COMPRESSION

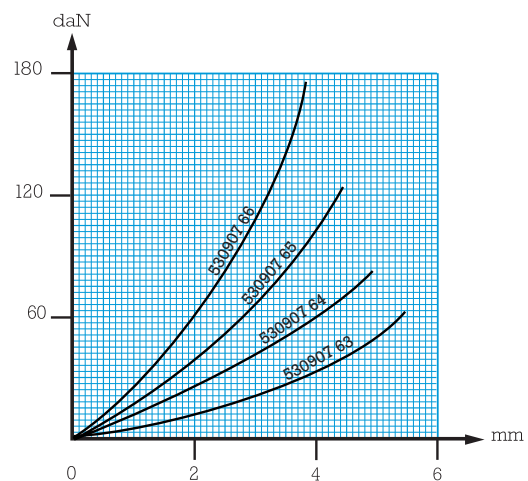
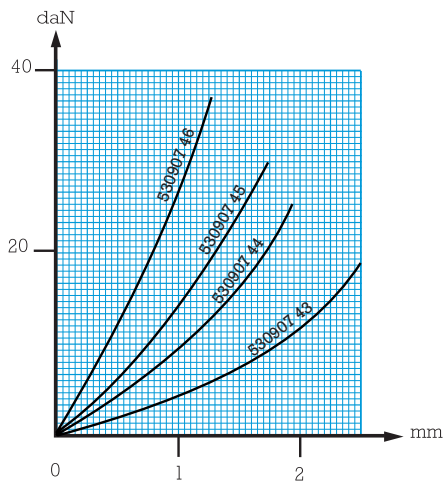
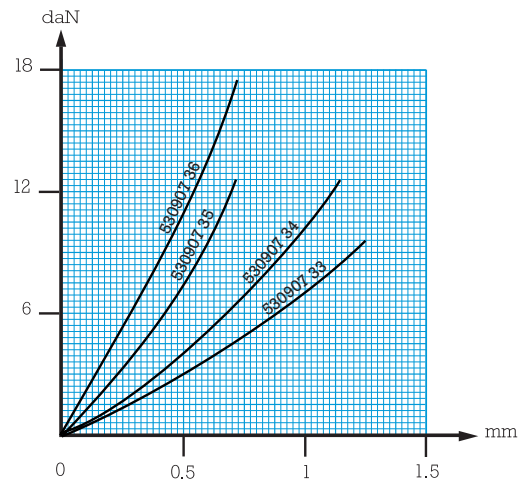
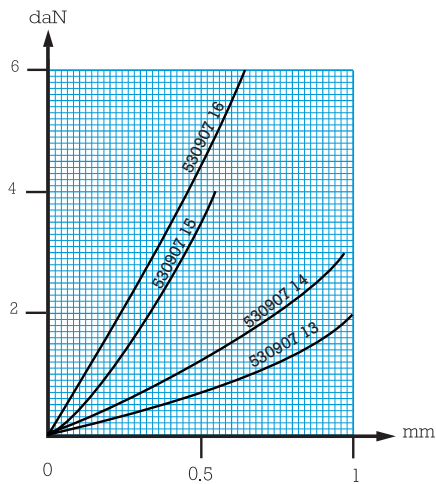

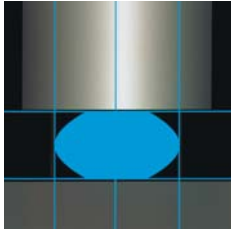

FLEX-LOC



DESCRIPTION

A flexible fixing resistant to oils, the majority of solvents and ageing.

OPERATION

The design of the FLEX-LOC mount gives the following basic characteristics:

- The rubber works in:
 - compression (axial),
 - shear (radial),
 - compression/shear according to the fixing method.

Advantages :

- 80 % reduction of vibrational energy transmitted from normal structural frequencies.
- Simple and economical.
- Simple to fix.
- Light weight.

APPLICATIONS

FLEX-LOC are suitable for the fixing of sheets, frameworks, engines, ventilators, electronic equipment, computers, etc.

DIMENSIONS CHARACTERISTICS

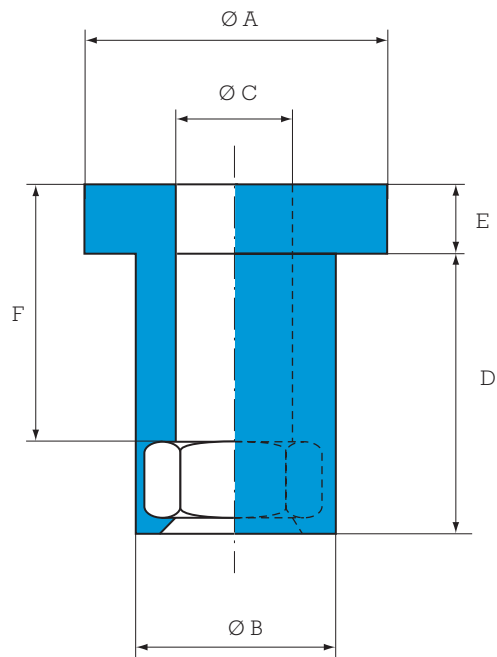

Paulstra reference	Barry Controls reference *	Nut	Ø A mm	Ø B mm	Ø C mm	D mm	E mm	F mm
530909 03	Q3	M3	9	7.2	3.4	9	2.5	8
530909 04	Q4	M4	12	9.3	4.4	11.5	3	10.5
530909 05	Q5	M5	15	10.2	5.4	14.5	3.5	13
530909 06	Q6	M6	18	12.7	6.4	17	4	15
530909 07	Q8	M8	24	16.5	8.4	22	5	19.5

* Barry Controls references are given as an indication.

OPERATING CHARACTERISTICS

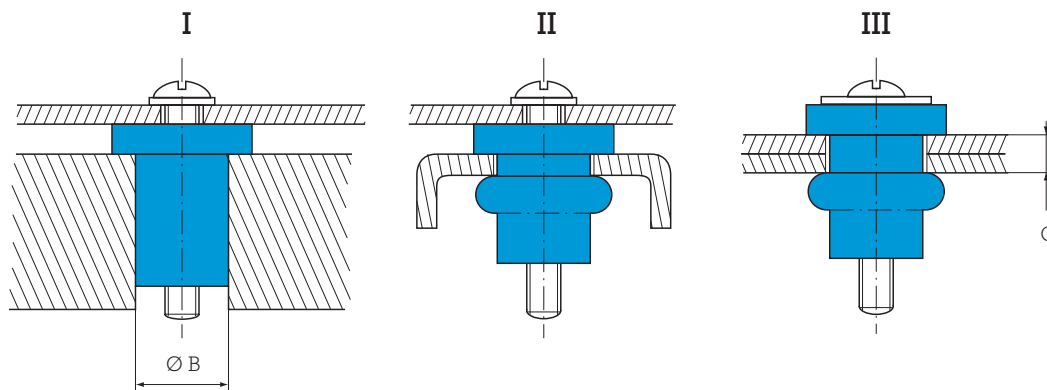

Paulstra reference	Barry Controls reference *	Clearance cole Ø B	Plate thickness G mm	Torque range		Static load (daN)		
				I Nm	II ou III Nm	I	II ou III	
						Compression/ shear	Compression	Shear
530909 03	Q3	7,2-7,5	0.6-2.5	0.5	0.4	1	5	2.5
530909 04	Q4	9,3-9,6	0.8-3.3	0.6	0.5	1	7	3.5
530909 05	Q5	10,2-10,5	0.8-4.3	1.0	0.6	1.5	10	5
530909 06	Q6	12,7-13,0	1.5-5.0	3.5	0.9	3	14	7
530909 07	Q8	16,5-16,8	1.5-6.5	4.0	1.8	5	28	14

* Barry Controls references are given as an indication.

1 kg ≈ 1 daN



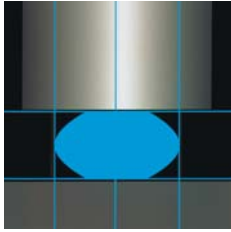

GB530

SPECIAL MARINE



(1) Natural frequency:
5 Hz

DESCRIPTION

The GB530 comprises of one part in elastomer bonded to a base plate and a tapped steel core (a non magnetic version is also available).

Advantages :

- Can provide high deflection under shocks.
- Long life.
- Low natural frequency (5 Hz in axial).
- Low amplification at resonance.

APPLICATIONS

These are specific mounts created for the naval industry: on board electronics, radars, special weapons equipment.

DIMENSIONS CHARACTERISTICS

Dimensions are given in mm

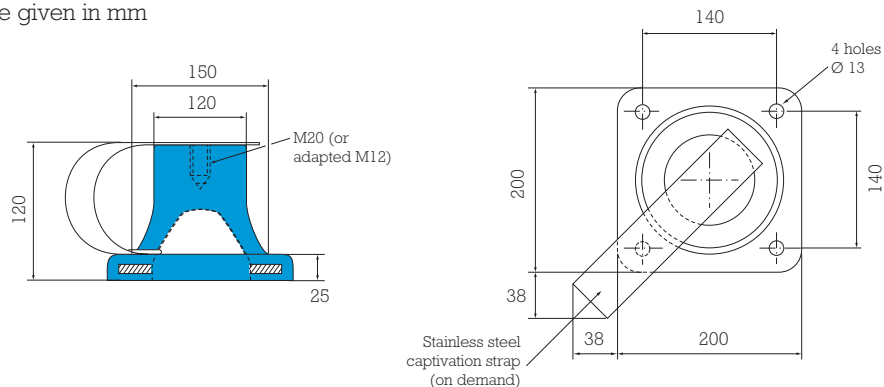

OPERATING CHARACTERISTICS

Paulstra reference	Barry Controls reference *	Load range daN
530901 21 00	GB530-NR1	7.5 - 75
530901 21 10	GB530-NR2	15 - 150
530901 21 20	GB530-NR3	25 - 250
530901 21 30	GB530-NR4	40 - 400
530901 21 40	GB530-NR5	60 - 600

Temperature range: - 30°C to + 70°C.
Weight: 3 - 4 kg.

(1) Natural frequencies with max/min loads, see : OPERATING CHARACTERISTICS.

* Barry Controls references are given as an indication.

1 kg \approx 1 daN



ALPHANUMERIC INDEX - BARRY CONTROLS RANGE

Reference	Designation	Page	Reference	Designation	Page	Reference	Designation	Page
530901 21 00	GB530	151	530906 21/26	Cupmount	144	530908 14	Bushing	148
530901 21 00	GB530	151	530906 31/34	Cupmount	144	530908 15	Bushing	148
530901 21 00	GB530	151	530906 41/44	Cupmount	144	530908 16	Bushing	148
530901 21 00	GB530	151				530908 33	Bushing	148
530901 21 00	GB530	151	530907 13	Ring	148	530908 34	Bushing	148
			530907 14	Ring	148	530908 35	Bushing	148
530903 11/15	22000 mount	140-141	530907 15	Ring	148	530908 36	Bushing	148
530903 21/25	22000 mount	140-141	530907 16	Ring	148	530908 43	Bushing	148
530903 31/35	22000 mount	140-141	530907 33	Ring	148	530908 44	Bushing	148
530903 41/45	22000 mount	140-141	530907 34	Ring	148	530908 45	Bushing	148
530903 51/55	22000 mount	140-141	530907 35	Ring	148	530908 46	Bushing	148
			530907 36	Ring	148	530908 63	Bushing	148
530904 01	SLM mount	137	530907 43	Ring	148	530908 64	Bushing	148
530904 02	SLM mount	137	530907 44	Ring	148	530908 65	Bushing	148
530904 03	SLM mount	137	530907 45	Ring	148	530908 66	Bushing	148
530904 04	SLM mount	137	530907 46	Ring	148			
530904 05	SLM mount	137	530907 63	Ring	148	530909 03	Flex-Loc	150
530904 06	SLM mount	137	530907 64	Ring	148	530909 04	Flex-Loc	150
530904 07	SLM mount	137	530907 65	Ring	148	530909 05	Flex-Loc	150
530904 08	SLM mount	137	530907 66	Ring	148	530909 06	Flex-Loc	150
						530909 07	Flex-Loc	150
530906 11/14	Cupmount	144	530908 13	Bushing	148			

OTHER PAULSTRA DOCUMENTATION

Available upon request

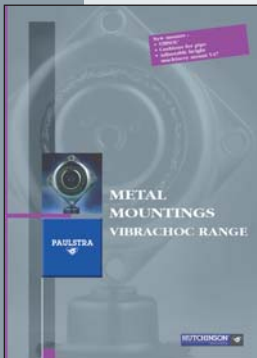

**METAL
MOUNTINGS**
CATALOG



**FLEXIBLE
COUPLINGS**
CATALOG



**FLEXIBLE
BUSHES**
CATALOG

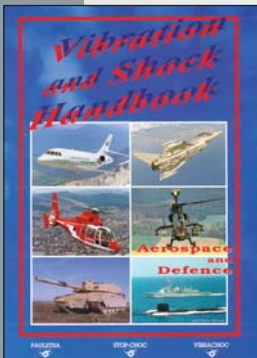

**AEROSPACE
AND DEFENCE**
CATALOG

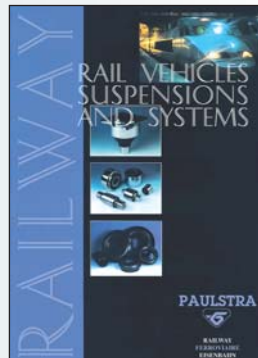

RAILWAY
CATALOG

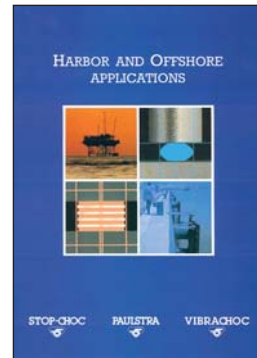

OFFSHORE
CATALOG

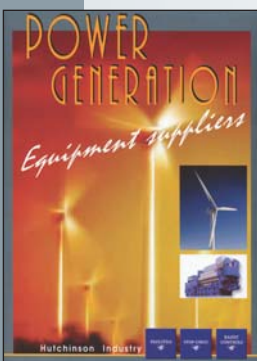

**POWER
GENERATION**
LEAFLET

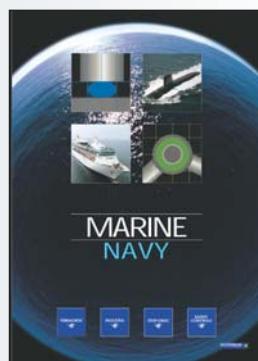

MARINE / NAVY
LEAFLET

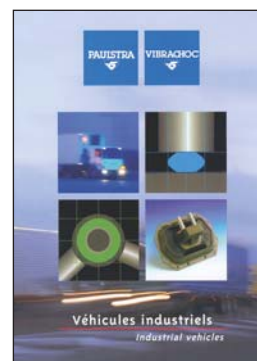

**INDUSTRIAL
VEHICLES**
LEAFLET



GreatOrientalTrading
www.gotrading.co.th

