



川源(中国)机械有限公司
GSD (China) Co., Ltd.



CP 沉水式污物(泥)泵

CP submersible solid handling pump



CP 沉水式污物(泥)泵

CP submersible solid handling pump

用途

- 废水扬升站
- 都市废水处理厂
- 一楼化粪池排水系统
- 农畜牧业废水处理系统
- 医院、学校、社区等生活废水处理系统
- 食品、造纸、采矿、纺织、皮革、化学工厂等工业之水处理系统
- 净水处理系统

特点

- **电动机**
鼠笼式感应电动机，F级绝缘，防护等级IP68。
- **不阻塞叶轮**
采用最新无堵塞理论设计的叶轮，流道宽大，水流畅通，污物容易通过，效率高。
所有叶轮均经动、静平衡校正，最大程度的减少了振动和噪音，运转平稳，寿命长。
- **机械密封**
机械密封的作用是隔绝抽送介质与电动机部分接触，双机械密封串联相互独立工作，为电动机提供双重保护。
- **自动着脱装置（选用配备）**
使泵浦安装、保养、修护迅速容易，毋须先清除桶槽污水。
- **测漏检知器**
在油室内加装测漏检知器，可检测因密封不良或机械密封损坏造成之洩漏（<15kW选用配备，≥15kW标准配备）。
大功率水泵在接线盒和电机腔内加装测漏检知器，可对接线盒和电机腔内的洩漏发出报警信号，使控制系统对泵实施保护（非标准配备，≥132kW可选配）。
- **过热保护器**
在电动机中加装过热保护器，对过载、温升等状况自动进行检测，避免由于电动机过热造成电机烧毁（<15kW选用配备，≥15kW标准配备）。
在轴承中加装过热保护器，当轴承温度升至断开温度时，保护器自动切断电源，起到保护轴承的作用（非标准配备，≥18.5kW可选配）。
- **水冷夹套（选用配备）**
泵工作时利用泵腔内压力使液体连续进入水冷夹套与电动机外壳的空间以带走电动机产生的热量，从而保证水泵在低水位正常工作（≥18.5kW可选配）。

Application

- Wastewater lift station.
- Municipal wastewater treatment plant.
- Building wastewater treatment system.
- Livestock animal husbandry wastewater treatment system.
- Hospital, school, community, etc. wastewater treatment system.
- Food, paper, mining, textile, leather, chemical industry, etc. wastewater treatment system.
- Water purification system.

Features

- **Motor**
Squirrel-cage, induction motors are F class insulation, motor protection grade is IP68.
- **Non-clog impeller**
Well statically & dynamically balanced Non-Clog impeller is designed to allow sizable spherical solids to pass the flow passage easily without clogging. It adopts rigorous technics so that vibration and noise can be farthest reduced.
- **Mechanical seal**
The mechanical seals protect the motor from contacting the pumping liquids. Two seals are in series with each other and individually work to provide the motor with a dual protection.
- **Auto-setter (options)**
To allow pump for easy installation, maintenance & reparation, as it is no need to empty the tank first.
- **Leakage detector**
Built-in leakage detector in the oil chamber can detect leakage from the damage of the mechanical seal. (Less than 15 kW options, No less than 15kW standard).
Built-in leakage detector in the wiring box and motor cavity of large power pumps can check if a leakage in it. The leakage detector offers pump an automatic protection (Not standard, No less than 132 kW options)
- **Heat-protector**
Built-in heat protector in motor, can prevent the motor from burning out, overload & overheating. (Less than 15 kW options, No less than 15 kW standard).
Built-in heat protector in bearing, when the bearing is abnormal and the temperature rises to disconnecting temperature, the protector automatically cut off power supply to protect the bearing. (Not standard, no less than 18.5 kW options).
- **Cooling house (options)**
Pumps make use of inner pressure of pump cavity to make liquid continually entering in space between cooling house and motor outer, to take away the heat of the motor. to make sure the regular work of the pump in low water level (No less than 18.5 kW options).



型号说明 Type description

CP - 5 37 - 300

出口口径
 额定功率
 频率
 沉水式污物(泥)泵

Outlet diameter (mm)
 Rated power (kW)
 Frequency 5: 50Hz
 Submersible solid handling pump

结构简图 Construction

NO.	名称 Name	材质 Material	
		GB	JIS
1	动力电缆 Power cable	NBR	NBR
2	电缆压盖 Cable cover	HT200	FC200
3	电缆固定套 Cable fixing sleeve	HT200	FC200
4	O型圈 O-ring	NBR	NBR
5	接线盒 Junction box	HT200	FC200
6	轴承 Bearing	-	-
7	马达本体 Motor casing	HT200	FC200
8	轴承压盖 Bearing cover	HT200	FC200
9	漏水检知器 Leakage detector	-	-
10	中承座 Bracket	HT200	FC200
11	机械密封 Mechanical seal	SiC-SiC	SiC-SiC
12	油箱盖 Oil cover	HT200	FC200
13	叶轮 Impeller	HT200	FC200
14	泵体 Pump casing	HT200	FC200
15	密封环 Seal-ring	ZCuSn10Pb5	LBC2
16	泵体底盖 Bottom cover	HT200	FC200
17	提升架 Lifting frame	06Cr19Ni10	SUS304
18	控制电缆 Control cable	NBR	NBR
19	电缆压盖 Cable cover	06Cr19Ni10	SUS304
20	马达盖 Motor cover	HT200	FC200
21	接线盒 Terminal block	HT200	FC200
22	主轴 Shaft	20Cr13	SUS420J1
23	转子 Rotor	-	-
24	定子 Stator	-	-
25	圆螺母 Round nut	45	S45C
26	机械密封 Mechanical seal	C-Al203	C-Al203
27	键 Key	20Cr13	SUS420J1
28	垫圈 Washer	20Cr13	SUS420J1
29	螺母 Nut	06Cr19Ni10	SUS304
30	排气阀 Exhaust valve	-	-
31	固定架 Fixed frame	Q235A	SS400
32	引导管 Pail piping	06Cr19Ni10	SUS304
33	引导板 Slide	HT200	FC200
34	配合凸缘 Flange setter	HT200	FC200
35	着脱本体 Duckfoot	HT200	FC200

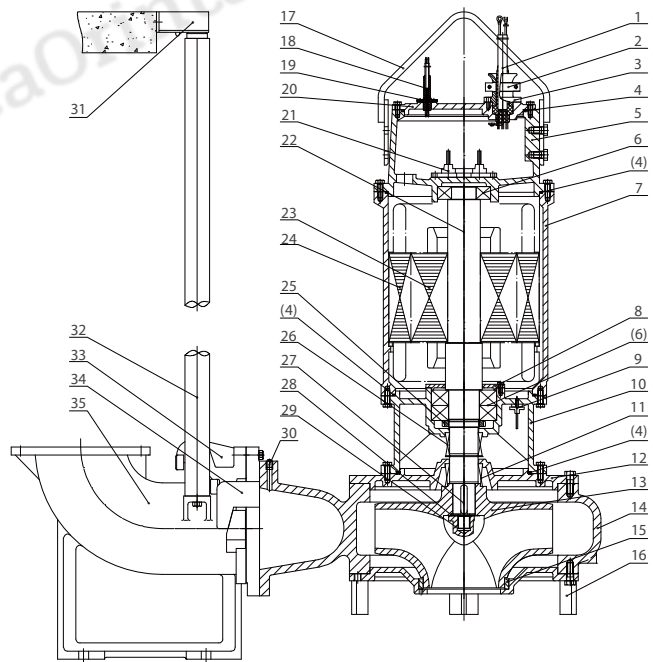

不同机型结构略有不同，可根据需求采用不同材质。
 Different model has a little difference,
 Materials can be selected according to the requirement of the customer.



型谱图 Performance chart

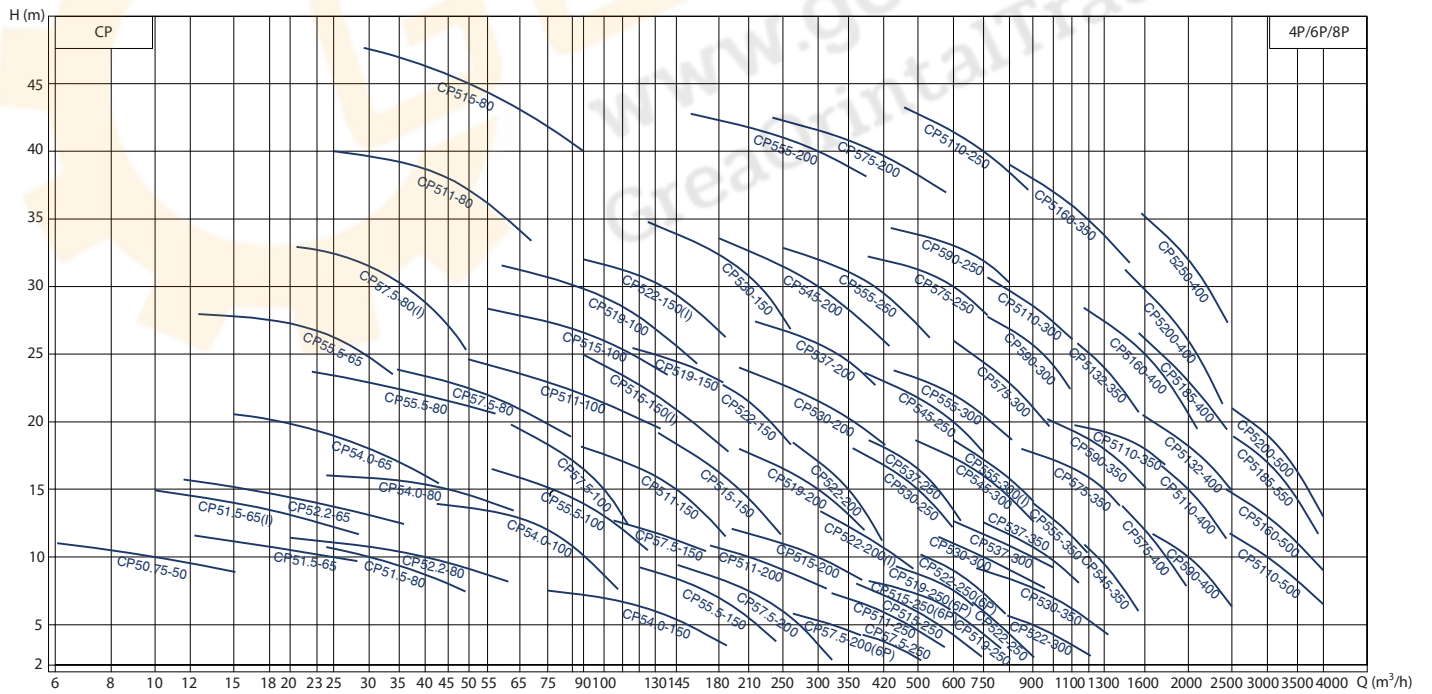
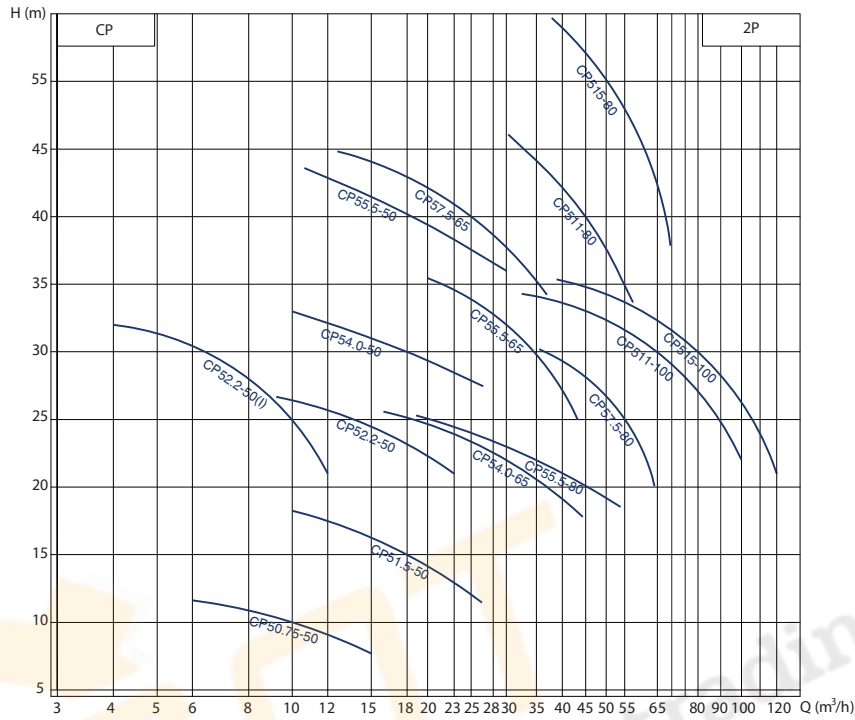

性能参数 Performance parameters

(2P)

泵型号 Pump model	行业型号 Pump model	转速 Speed (r/min)	流量 Capacity (m ³ /h)	扬程 Head (m)	效率 Eff. η (%)	电机功率 Motor power (kw)	口径 Dia. (mm)	泵重量 Weight (kg)
CP50.75-50	50QW10-10-0.75	2840	10	10	48	0.75	50	22.5
CP51.5-50	50QW18-15-1.5	2840	18	15	60	1.5	50	28
CP52.2-50(I)	50QW8-28-2.2	2840	8	28	45	2.2	50	37
CP52.2-50	50QW15-24.5-2.2	2840	15	24.5	56	2.2	50	36
CP54.0-50	50QW18-30-4	2840	18	30	50	4	50	56
CP55.5-50	50QW18-40-5.5	2860	18	40	50	5.5	50	68
CP54.0-65	65QW30-22-4	2840	30	22	62	4	65	54
CP55.5-65	65QW30-32-5.5	2860	30	32	58	5.5	65	68
CP57.5-65	65QW25-40-7.5	2860	25	40	55	7.5	65	114
CP55.5-80	80QW35-22-5.5	2860	35	22	55	5.5	80	66
CP57.5-80	80QW55-25-7.5	2860	55	25	56	7.5	80	100
CP511-80	80QW45-40-11	2860	45	40	60	11	80	192
CP515-80	80QW50-50-15	2860	50	50	55	15	80	206
CP511-100	100QW65-30-11	2860	65	30	60	11	100	184
CP515-100	100QW80-30-15	2860	80	30	65	15	100	200

(4P/6P/8P)

泵型号 Pump model	行业型号 Pump model	转速 Speed (r/min)	流量 Capacity (m ³ /h)	扬程 Head (m)	效率 Eff. η (%)	电机功率 Motor power (kw)	口径 Dia. (mm)	泵重量 Weight (kg)
CP50.75-50	50QW10-10-0.75	1450	10	10	50	0.75	50	35
CP51.5-65(I)	65QW18-13.5-1.5	1450	18	13.5	50	1.5	65	51
CP51.5-65	65QW25-10-1.5	1450	25	10	60	1.5	65	48
CP52.2-65	65QW23-14-2.2	1450	23	14	50	2.2	65	60
CP54.0-65	65QW30-18-4	1450	30	18	55	4	65	77
CP55.5-65	65QW26-26-5.5	1450	26	26	51	5.5	65	117
CP51.5-80	80QW30-10-1.5	1450	30	10	60	1.5	80	48
CP52.2-80	80QW40-10-2.2	1450	40	10	55	2.2	80	57
CP54.0-80	80QW45-15-4	1450	45	15	57	4	80	81
CP55.5-80	80QW40-22-5.5	1450	40	22	55	5.5	80	121
CP57.5-80(I)	80QW36-30-7.5	1450	36	30	53	7.5	80	121
CP57.5-80	80QW55-22-7.5	1450	55	22	62	7.5	80	134
CP511-80	80QW45-38-11	1450	45	38	56	11	80	300
CP515-80	80QW50-45-15	1450	50	45	55	15	80	324
CP54.0-100	100QW75-12-4	1450	75	12	70	4	100	81
CP55.5-100	100QW95-13.5-5.5	1450	95	13.5	73	5.5	100	116
CP57.5-100	100QW100-15-7.5	1450	100	15	65	7.5	100	134
CP511-100	100QW90-22-11	1450	90	22	62	11	100	238
CP515-100	100QW100-26-15	1450	100	26	65	15	100	265
CP519-100	100QW110-28.5-18.5	1450	110	28.5	63	18.5	100	315
CP54.0-150	150QW130-6-4	1450	130	6	66	4	150	100
CP55.5-150	150QW180-7-5.5	1450	180	7	73	5.5	150	122
CP57.5-150	150QW120-12-7.5	1450	120	12	70	7.5	150	132
CP511-150	150QW145-15-11	1450	145	15	65	11	150	257
CP515-150(I)	150QW130-22-15	1450	130	22	65	15	150	262
CP515-150	150QW200-15-15	1450	200	15	74	15	150	265
CP519-150	150QW170-23.5-18.5	1450	170	23.5	73	18.5	150	348
CP522-150(I)	150QW135-30-22	1450	135	30	69	22	150	346
CP522-150	150QW200-22-22	1450	200	22	71	22	150	359
CP530-150	150QW220-30-30	1450	220	30	75	30	150	445
CP57.5-200	200QW250-6-7.5	1450	250	6	67	7.5	200	148
CP57.5-200	200QW350-4.5-7.5	980	350	4.5	70	7.5	200	260
CP511-200	200QW210-10-11	1450	210	10	65	11	200	289
CP515-200	200QW300-10-15	1450	300	10	68	15	200	301



性能参数 Performance parameters

(4P/6P/8P)

泵型号 Pump model	行业型号 Pump model	转速 Speed (r/min)	流量 Capacity (m ³ /h)	扬程 Head (m)	效率 Eff. η (%)	电机功率 Motor power (kw)	口径 Dia. (mm)	泵重量 Weight (kg)
CP519-200	200QW300-15-18.5	1450	300	15	75	18.5	200	450
CP522-200(I)	200QW450-10-22	1450	450	10	68	22	200	445
CP522-200	200QW350-15-22	1450	350	15	72	22	200	452
CP530-200	200QW360-20-30	980	360	20	76	30	200	631
CP537-200	200QW350-24.5-37	980	350	24.5	75	37	200	735
CP545-200	200QW300-30-45	980	300	30	68	45	200	1120
CP555-200	200QW300-40-55	980	300	40	70	55	200	1015
CP575-200	200QW400-40-75	980	400	40	70	75	200	1650
CP57.5-250	250QW400-4-7.5	980	400	4	62	7.5	250	300
CP511-250	250QW400-6-11	980	400	6	69	11	250	380
CP515-250	250QW500-6-15	1450	500	6	71	15	250	365
CP515-250	250QW600-6-15	980	600	6	78	15	250	400
CP519-250	250QW600-6-18.5	1450	600	6	71	18.5	250	400
CP519-250	250QW600-7-18.5	980	600	7.5	75	18.5	250	480
CP522-250	250QW700-6-22	1450	700	6	73	22	250	415
CP522-250	250QW600-9-22	980	600	9	75	22	250	500
CP530-250	250QW500-15-30	980	500	15	75	30	250	700
CP537-250	250QW500-16.5-37	980	500	16.5	77	37	250	810
CP545-250	250QW600-20-45	980	600	20	78	45	250	930
CP555-250	250QW400-30-55	980	400	30	72	55	250	1090
CP575-250	250QW600-30-75	980	600	30	76	75	250	1350
CP590-250	250QW600-38-90	990	600	38	76	90	250	2000
CP5110-250	250QW700-40-110	990	700	40	78	110	250	1650
CP522-300	300QW900-5-22	980	900	5	70	22	300	650
CP530-300	300QW700-10-30	980	700	10	70	30	300	715
CP537-300	300QW900-10-37	980	900	10	75	37	300	820
CP545-300	300QW700-16-45	980	700	16	78	45	300	1090
CP555-300(I)	300QW850-15-55	980	850	15	78	55	300	1050
CP555-300	300QW600-22-55	980	600	22	75	55	300	1160
CP575-300	300QW850-22-75	980	850	22	78	75	300	1420
CP590-300	300QW950-25-90	990	950	25	79	90	300	1800
CP5110-300	300QW950-28-110	990	950	28	80	110	300	2200
CP530-350	350QW1000-7-30	980	1000	7	75	30	350	760
CP537-350	350QW1000-9.5-37	980	1000	9.5	75	37	350	850
CP545-350	350QW1300-9.5-45	980	1300	9.5	78	45	350	1000
CP555-350	350QW1100-11.5-55	980	1100	11.5	75	55	350	1180
CP575-350	350QW1300-15-75	980	1300	15	78	75	350	1400
CP590-350	350QW1300-18-90	990	1300	18	78	90	350	1470
CP5110-350	350QW1600-18-110	990	1600	18	79	110	350	2300
CP5132-350	350QW1300-24-132	740	1300	24	75	132	350	2300
CP5160-350	350QW1100-36-160	740	1100	36	75	160	350	2880
CP575-400	400QW1600-12-75	980	1600	12	80	75	400	1436
CP590-400	400QW2000-10-90	990	2000	10	75	90	400	1250
CP5110-400	400QW2000-15-110	990	2000	15	79	110	400	2350
CP5132-400	400QW2200-17-132	740	2200	17	81	132	400	2520
CP5160-400	400QW1600-25-160	740	1600	25	76	160	400	2880
CP5185-400	400QW2000-23-185	740	2000	23	81	185	400	3200
CP5200-400	400QW2000-26-200	740	2000	26	80	200	400	3850
CP5250-400	400QW2000-32-250	740	2000	32	80	250	400	4690
CP5110-500	500QW3000-10-110	990	3000	10	80	110	500	2200
CP5160-500	500Q3000-13-160	740	3000	13	80	160	500	2950
CP5185-500	450QW3000-17-185	740	3000	17	80	185	500	3250
CP5200-500	450QW3000-19-200	740	3000	19	80	200	500	4200



安装示意图 Installation sketch map

未附着脱
without autosetter

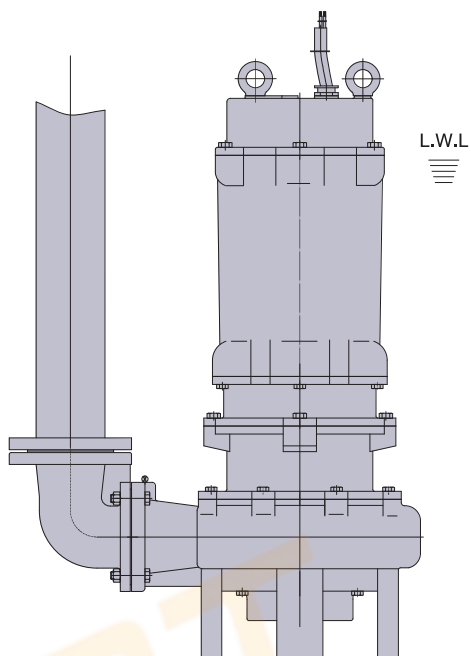

附着脱
with autosetter

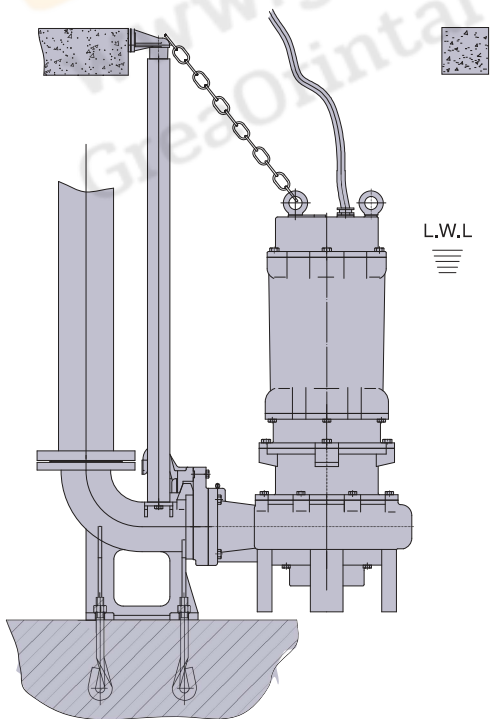

欢迎索取以下产品型录



泵系列

潜水泵系列 | 陆上泵系列 | 特种泵系列



搅拌推流系列

搅拌机系列 | 推流器系列



供氧曝气系列

曝气机系列 | 曝气盘系列 | 曝气管系列



风机系列

三叶罗茨鼓风机系列 | 增压罗茨鼓风机 | 沉水式风机 | 空气悬浮离心鼓风机



污泥处理设备

带式脱水机 | 厢式压滤机 | 非金属矩形刮泥机 | 浅层高效气浮设备



智能化系列

EP6 物联监控管理系统 | 空气质量管理系统 | RS-485 传感器



反应器及套装设备

芬顿反应系统 | MBR生物膜反应器 | 预制泵站 | 一体化污水处理设备



耗材药剂及相关设备

生物绳 | PAC 聚合氯化铝 | PAM 聚丙烯酰胺 | 泡药设备



环保设备和技术服务的专业伙伴

บริษัท เกรทโอเรียนเต็ลเทรดดิ้ง จำกัด
เลขที่ 1049 ถนนร่วมธรรม
ตำบลค้อหงส์ อำเภอหาดใหญ่
จังหวัดสงขลา 90110
074-300212-4

