



川源(中国)机械有限公司
GSD (China) Co., Ltd.



ISH/ISP

卧式端吸泵

ISH/ISP
Horizontal End Suction Pump

ISO2858

ISH/ISP 卧式端吸泵

ISH/ISP Horizontal End Suction Pump

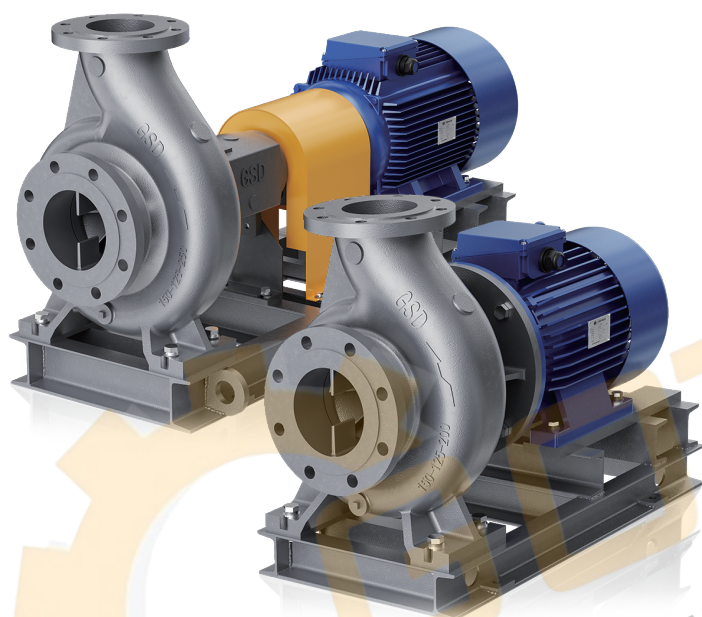

用途

- 暖通空调冷热水循环系统
- 一般工业用水
- 污水处理设备
- 高楼给水
- 锅炉给水
- 土木施工用水
- 农业灌溉用水
- 设备配套

Application

- Air-condition cold or hot water circulation
- Industrial water supply
- Construction engineering water supply
- Waste water treatment
- Agricultural irrigation
- Water-supplying system of apartment building
- Boiler water supply
- Serving in system equipment

特点 Features

- ISP泵外形及安装尺寸依据GB/T 5662 (ISO 2858) 标准设计。
- 从泵进口看，泵为逆时针方向旋转。
- 采用后拉式结构，维修时无须拆除泵体及管路，安装维护方便。
- 零件通用性广，ISH和ISP共用泵体，叶轮及后盖。
- 低噪音。
- 长寿命。
- 结构紧凑。
- 可根据要求采用不同材质。
- Pump outline and installation dimensions are designed according to GB/T 5662 (ISO 2858) standard.
- Seen from the pump inlet, the pump rotates counterclockwise.
- With the back-pull structure, it is easy to install and maintain without removing the pump casing and pipeline during maintenance.
- The parts are commonly interchangeable. ISH and ISP share the pump body, impeller and back cover.
- Low noise.
- Long life.
- Compact structure.
- Materials can be selected according to the requirements of the customers.

结构说明 Construction description

- ISP泵与电机之间采用弹性联轴器相连。
- ISH泵采用直联式加长轴结构，结构紧凑。
- 泵体：底脚支撑结构，螺旋形蜗壳。铸铁泵体进出口法兰符合GB/T 17241.6(ISO 7005-2)，压力等级1.6MPa；不锈钢泵体进出口法兰符合GB/T 9124.1(ISO 7005-1)，压力等级1.6MPa；如要求符合其他法兰标准，请向我司咨询。
- 叶轮：闭式叶轮，采用优秀的水力模型设计，低能耗，并进行平衡试验。
- ISP泵采用轴承体结构，轴承体内装有轴承，轴承标配用润滑脂润滑，也可选配油润滑。
- 轴封：采用机封密封结构，可选用国产及进口优质机封。
- 电机：选用优质高效节能电机，噪音低，振动小，也可根据需要配用防爆或特殊要求电机。
- ISP pump and motor are connected by elastic coupling.
- ISH pump has a compact structure adopting direct connection with extended shaft.
- Pump casing: foot support structure, spiral volute. Cast iron pump casing inlet flange and outlet flange conform to GB/T 17241.6 (ISO 7005-2), pressure grade 1.6MPa; Stainless steel pump casing inlet flange and outlet flange conform to GB/T 9124.1 (ISO 7005-1), pressure grade 1.6MPa; Other flange standards can be provided upon request.
- Impeller: the closed impeller is designed with excellent hydraulic model, low energy consumption, and balance test.
- ISP pump adopts bearing structure with bearings inside, and the bearings are lubricated with grease as standard or oil as optional.
- Shaft seal: using mechanical seal. Domestic and imported high-quality mechanical seal may also be adopted.
- Motor: high-quality motor with low noise and small vibration. Explosion-proof motor or other motors with special requirements may be adopted if necessary.

工作条件 Working condition

- 流量范围：5~800m³/h
- 扬程范围：5~140m
- 输送介质温度：-10°C~85°C(如超过温度范围，请向我司咨询)。
- 最大工作压力：1.6MPa(如需提高，请向我司咨询)。
- 最大进口压力：0.6MPa(如超过压力范围，请向我司咨询)。
- 进出口径：DN32~DN250mm
- Capacity: 5~800m³/h
- Head: 5~140m
- Conveying medium temperature: -10°C~85°C(Please contact us if the temperature exceeds the range).
- Maximum working pressure: 1.6MPa (Please contact us if higher pressure is required).
- Maximum inlet pressure: 0.6MPa (Please contact us if higher pressure is required).
- Inlet and outlet diameter: DN32~DN250mm



型号说明 Type description

ISH 50 - 32 - 125 A

不标: 原型	Not labeled: prototype
A: 叶轮外径第一次切割	A: Impeller outer diameter first cut
B: 叶轮外径第二次切割	B: Impeller outer diameter second cut
C: 叶轮外径第三次切割	C: Impeller outer diameter third cut
Z: 叶轮外径增大型	Z: Impeller outer diameter enlarge type
叶轮名义直径 (mm)	Nominal diameter for impeller
泵出口口径 (mm)	Diameter of pump outlet (mm)
泵进口口径 (mm)	Diameter of pump inlet (mm)
单级卧式离心泵	Single-stage horizontal centrifugal pump
ISH: 直联式	ISH: Coaxial Pump
ISP: 联轴式	ISP: Coupling pump

结构简图 Construction

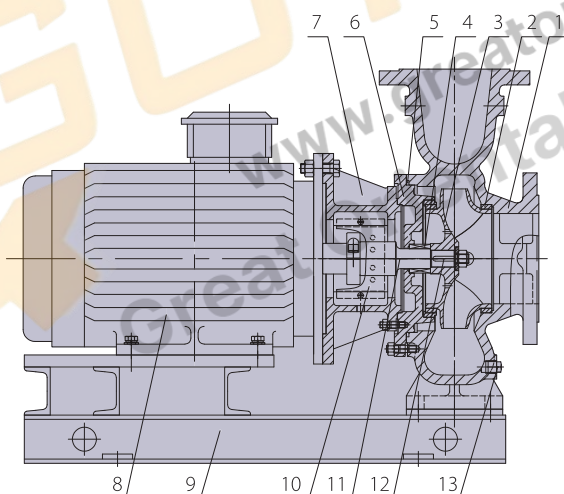

ISH

NO.	名称 Name	材质 Material				NO.	名称 Name	材质 Material			
		HT		304				HT		304	
		GB	JIS	GB	JIS			GB	JIS	GB	JIS
1	泵体 Pump casing	HT250	FC250	ZG07Cr19Ni10	SCS13	8	电机 Motor	-	-	-	-
2	密封环 Seal ring	C/Cu	C/Cu	06Cr19Ni10/-	SUS304/-	9	底座 Base	Q235A	SS400	Q235A	SS400
3	叶轮 Impeller	HT200	FC200	ZG07Cr19Ni10	SCS13	10	防护板 Guard board	06Cr19Ni10	SUS304	06Cr19Ni10	SUS304
4	机械密封 Mechanical seal	C/SiC-NBR	C/SiC-NBR	C/SiC-VITON	C/SiC-VITON	11	套筒轴 Shaft	20Cr13	SUS420	06Cr19Ni10	SUS304
5	O型圈 O-ring	NBR	NBR	VITON	VITON	12	键 Key	20Cr13	SUS420	06Cr19Ni10	SUS304
6	后盖 Back cap	HT250	FC250	ZG07Cr19Ni10	SCS13	13	丝堵 Plug	Q235A	SS400	06Cr19Ni10	SUS304
7	中承座 Bracket	HT250	FC250	HT250	FC250						



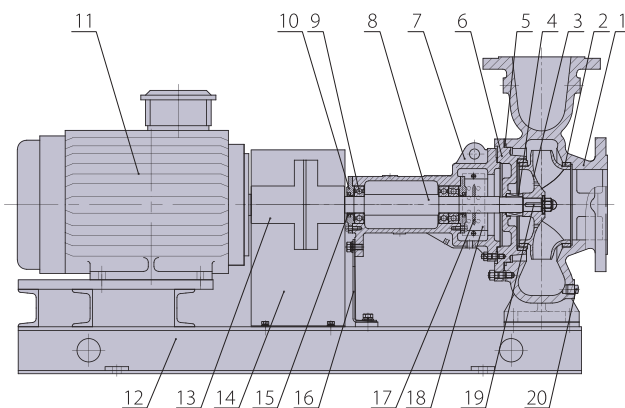

ISP

NO.	名称 Name	材质 Material				NO.	名称 Name	材质 Material			
		HT		304				HT		304	
		GB	JIS	GB	JIS			GB	JIS	GB	JIS
1	泵体 Pump casing	HT250	FC250	ZG07Cr19Ni10	SCS13	11	电机 Motor	-	-	-	-
2	密封环 Seal ring	C/Cu	C/Cu	06Cr19Ni10/-	SUS304/-	12	底座 Base	Q235A	SS400	Q235A	SS400
3	叶轮 Impeller	HT200	FC200	ZG07Cr19Ni10	SCS13	13	联轴器 Coupling	-	-	-	-
4	机械密封 Mechanical seal	C/SiC-NBR	C/SiC-NBR	C/SiC-VITON	C/SiC-VITON	14	联轴器罩 Coupling housing	Q235A	SS400	Q235A	SS400
5	O型圈 O-ring	NBR	NBR	VITON	VITON	15	VD密封圈 VD Seal ring	VITON	VITON	VITON	VITON
6	后盖 Back cap	HT250	FC250	ZG07Cr19Ni10	SCS13	16	轴承体支架 Bearing stand	Q235A	SS400	Q235A	SS400
7	轴承体 Bearing body	HT250	FC250	HT250	FC250	17	挡水圈 Block water ring	NBR	NBR	NBR	NBR
8	主轴 Shaft	20Cr13	SUS420	06Cr19Ni10	SUS304	18	防护板 Guard board	06Cr19Ni10	SUS304	06Cr19Ni10	SUS304
9	轴承 Bearing	-	-	-	-	19	键 Key	20Cr13	SUS420	06Cr19Ni10	SUS304
10	轴承压盖 Bearing cover	HT250	FC250	HT250	HT250	20	丝堵 Plug	Q235A	SS400	06Cr19Ni10	SUS304

型谱图 Performance chart

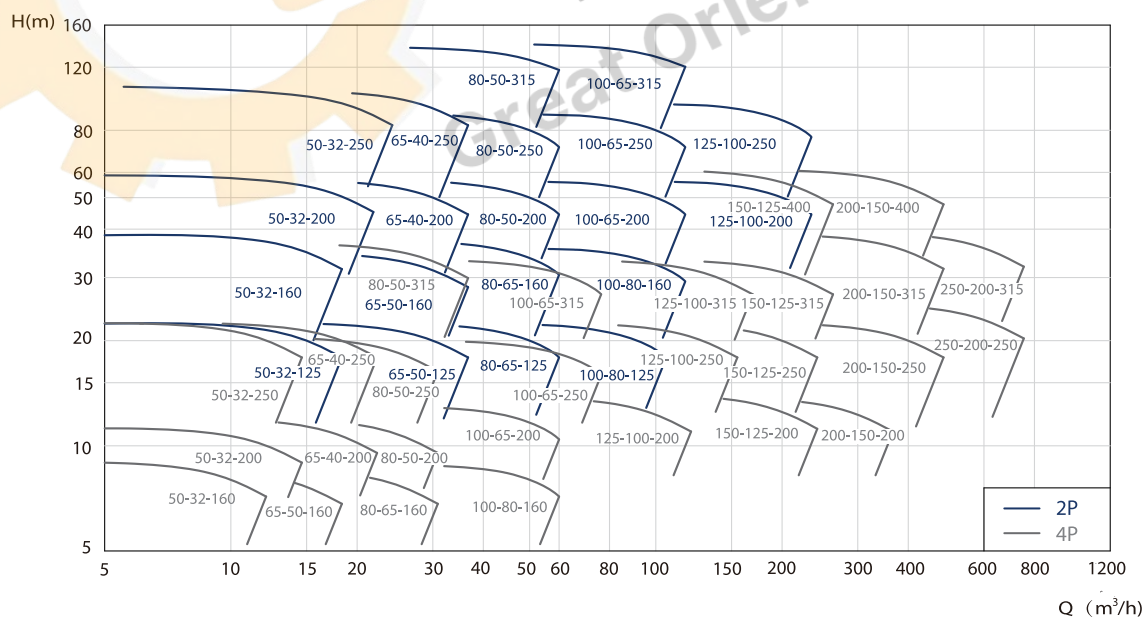

性能参数 Performance parameters

(2P)

型号 Type	电机功率 Motor power (kW)	转速 Speed (r/min)	流量 Capacity (m³/h)	扬程 Head (m)	效率 Eff (%)	必须气蚀余量 NPSHr (m)	ISH/ISP重量 ISH/ISP Weight (kg)
ISH/ISP150-32-125	1.5	2900	10.5	22	58	2.0	55/93
			15	20	65	2.1	
			18	18	64	2.4	
ISH/ISP50-32-125A	1.1	2900	9	17	57	2.0	49/87
			13	15	64	2.0	
			15.5	13	63	2.4	
ISH/ISP50-32-125B	0.75	2900	8.5	12	56	2.0	44/82
			12	10	63	2.0	
			14.5	9	62	2.3	
ISH/ISP50-32-160	3	2900	10.5	36	50	2.0	65/103
			15	33	58	2.1	
			18	30	59	2.5	
ISH/ISP50-32-160A	2.2	2900	9	30	50	2.0	55/93
			13	28	57	2.1	
			15.5	26	58	2.5	
ISH/ISP50-32-160B	1.5	2900	8.5	24	49	2.0	46/84
			12	22	56	2.0	
			14.5	20	57	2.4	
ISH/ISP50-32-200	5.5	2960	12.5	55	50	2.0	122/160
			18	52	57	2.1	
			21.5	48	58	2.5	
ISH/ISP50-32-200A	4	2900	11	46	49	2.0	103/141
			16	44	56	2.1	
			19	42	57	2.5	
ISH/ISP50-32-200B	4	2900	10.5	40	48	2.0	103/141
			15	38	55	2.0	
			18	36	56	2.3	
ISH/ISP50-32-250	15	2960	14	92	42	2.0	201/251
			20	90	48	2.3	
			24	88	49	2.6	
ISH/ISP50-32-250A	11	2960	12.5	83	41	2.0	201/251
			18	80	47	2.2	
			21.5	76	48	2.5	
ISH/ISP50-32-250B	7.5	2960	11	68	40	2.0	154/204
			16	66	46	2.2	
			19	64	47	2.5	
ISH/ISP65-50-125	3	2900	21	23	65	2.0	74/112
			30	20	72	2.0	
			36	16	71	2.4	
ISH/ISP65-50-125A	2.2	2900	19	19	64	2.0	52/90
			27	16	71	2.0	
			32.5	13	70	2.4	
ISH/ISP65-50-125B	1.5	2900	17.5	15	63	2.0	49/87
			25	13	70	2.0	
			30	11	69	2.3	
ISH/ISP65-50-160	4	2900	21	35	65	2.0	95/133
			30	32	71	2.1	
			36	29	70	2.5	
ISH/ISP65-50-160A	4	2900	19.5	31	64	2.0	95/133
			28	28	70	2.1	
			33.5	25	69	2.5	
ISH/ISP65-50-160B	3	2900	17.5	27	63	2.0	85/123
			25	24	69	2.0	
			30	21	68	2.4	
ISH/ISP65-40-200	7.5	2960	21	54	57	2.0	117/155
			30	50	64	2.2	
			36	47	65	2.5	
ISH/ISP65-40-200A	7.5	2960	19	47	56	2.0	111/149
			28	44	63	2.2	
			32.5	41	64	2.5	
ISH/ISP65-40-200B	5.5	2960	17.5	40	55	2.0	109/147
			25	38	62	2.1	
			30	35	63	2.4	



性能参数 Performance parameters

(2P)

型号 Type	电机功率 Motor power (kW)	转速 Speed (r/min)	流量 Capacity (m ³ /h)	扬程 Head (m)	效率 Eff (%)	必须气蚀余量 NPSHr (m)	ISH/ISP重量 ISH/ISP Weight (kg)
ISH/ISP65-40-250	18.5	2960	21	93	48	2.0	232/282
			30	90	55	2.3	
			36	88	54	2.6	
ISH/ISP65-40-250A	15	2960	19.5	85	47	2.0	225/275
			28	82	54	2.2	
			33.5	80	53	2.5	
ISH/ISP65-40-250B	11	2960	17.5	69	46	2.0	225/275
			25	66	53	2.0	
			30	64	52	2.5	
ISH/ISP80-65-125	4	2900	35	22	68	2.0	95/133
			50	20	76	2.6	
			60	17	75	3.0	
ISH/ISP80-65-125A	3	2900	31	18	67	2.0	85/123
			44	16	75	2.5	
			53	14	74	3.0	
ISH/ISP80-65-125B	2.2	2900	28	15	66	2.0	69/107
			40	13	74	2.5	
			48	11	73	2.8	
ISH/ISP80-65-160	7.5	2960	35	36	68	2.0	127/165
			50	34	75	2.5	
			60	32	74	2.8	
ISH/ISP80-65-160A	7.5	2960	33	32	67	2.0	127/165
			47	30	74	2.3	
			56	28	73	2.7	
ISH/ISP80-65-160B	5.5	2960	31	28	66	2.0	119/157
			44	26	73	2.3	
			52	24	72	2.6	
ISH/ISP80-50-200	15	2960	35	54	65	2.0	205/243
			50	50	71	2.4	
			60	47	69	2.7	
ISH/ISP80-50-200A	11	2960	33	48	65	2.0	204/242
			47	46	70	2.3	
			56	44	68	2.7	
ISH/ISP80-50-200B	11	2960	31	42	64	2.0	204/242
			44	40	69	2.2	
			52	38	67	2.5	
ISH/ISP80-50-250	22	2960	35	82	60	2.0	276/326
			50	80	64	2.2	
			60	76	63	2.6	
ISH/ISP80-50-250A	18.5	2960	33	72	59	2.0	234/284
			47	70	63	2.1	
			56	66	62	2.6	
ISH/ISP80-50-250B	15	2960	31	62	58	2.0	227/277
			44	60	62	2.1	
			52	56	61	2.6	
ISH/ISP80-50-315	37	2960	35	127	52	2.0	417/467
			50	125	58	2.0	
			60	122	59	2.5	
ISH/ISP80-50-315A	30	2960	33	110	52	2.0	382/432
			47	106	58	2.0	
			56	102	59	2.5	
ISH/ISP80-50-315B	30	2960	31	98	50	2.0	382/432
			44	95	56	2.0	
			52	90	57	2.5	
ISH/ISP100-80-125	7.5	2960	63	23	70	3.0	127/165
			90	20	77	4.0	
			108	17	75	4.8	
ISH/ISP100-80-125A	5.5	2960	60	18	70	2.9	125/163
			85	16	77	3.9	
			102	13	75	4.6	
ISH/ISP100-80-125B	4	2900	51	13	69	2.8	106/144
			72	12	76	3.7	
			87	10	74	4.4	



性能参数 Performance parameters

(2P)

型号 Type	电机功率 Motor power (kW)	转速 Speed (r/min)	流量 Capacity (m³/h)	扬程 Head (m)	效率 Eff (%)	必须气蚀余量 NPSHr (m)	ISH/ISP重量 ISH/ISP Weight (kg)
ISH/ISP100-80-160	15	2960	70	36	70	3.0	210/260
			100	33	78	4.1	
			120	28	76	4.9	
ISH/ISP100-80-160A	11	2960	66	34	70	2.9	210/260
			94	29	78	3.9	
			113	24	76	4.7	
ISH/ISP100-80-160B	11	2960	61	29	68	2.8	208/258
			87	26	75	3.8	
			104	22	73	4.5	
ISH/ISP100-65-200	22	2960	70	52	70	2.8	271/321
			100	50	77	3.8	
			120	46	75	4.4	
ISH/ISP100-65-200A	18.5	2960	66	46	69	2.7	229/279
			94	44	76	3.7	
			113	40	74	4.3	
ISH/ISP100-65-200B	18.5	2960	61	43	69	2.6	222/272
			87	41	76	3.5	
			104	38	74	4.1	
ISH/ISP100-65-250	37	2960	70	85	65	2.6	399/549
			100	80	73	3.5	
			120	74	71	4.1	
ISH/ISP100-65-250A	30	2960	66	70	65	2.5	364/414
			94	64	73	3.4	
			113	58	71	4.0	
ISH/ISP100-65-250B	30	2960	61	62	64	2.4	364/414
			87	57	71	3.3	
			104	52	69	3.8	
ISH/ISP100-65-315	75	2960	70	140	63	2.4	675/745
			100	135	67	3.2	
			120	130	66	3.8	
ISH/ISP100-65-315A	55	2960	66	115	62	2.3	586/656
			94	112	66	3.1	
			113	105	65	3.6	
ISH/ISP100-65-315B	45	2960	61	100	61	2.2	469/539
			87	96	65	3.0	
			104	90	64	3.5	
ISH/ISP125-100-200	37	2960	140	55	74	4.8	371/421
			200	50	81	6.5	
			240	45	80	7.7	
ISH/ISP125-100-200A	30	2960	126	45	73	4.6	336/386
			180	42	79	6.2	
			216	38	78	7.3	
ISH/ISP125-100-200B	30	2960	112	40	73	4.3	336/386
			160	37	78	5.7	
			192	33	77	6.8	
ISH/ISP125-100-250	75	2960	140	96	72	4.5	675/745
			200	90	79	6.0	
			240	84	78	7.1	
ISH/ISP125-100-250A	55	2960	131	74	71	4.4	586/656
			187	70	78	5.8	
			224	64	77	6.8	
ISH/ISP125-100-250B	45	2960	121	65	70	4.2	469/539
			173	60	77	5.6	
			208	56	76	6.6	
ISH/ISP125-100-315	110	2960	140	128	72	4.2	960/1070
			200	125	78	5.6	
			240	115	77	6.5	
ISH/ISP125-100-315A	110	2960	131	112	71	4.0	960/1070
			187	110	77	5.4	
			224	100	76	6.3	
ISH/ISP125-100-315B	90	2960	121	98	70	3.9	745/855
			173	95	76	5.2	
			208	90	75	6.1	

注：不同品牌电机，重量有所不同，具体请咨询本公司销售人员。

Note: The weight is different if using different brands of motor. Please contact our sales for details.



性能参数 Performance parameters

(4P)

型号 Type	电机功率 Motor power (kW)	转速 Speed (r/min)	流量 Capacity (m ³ /h)	扬程 Head (m)	效率 Eff (%)	必须气蚀余量 NPSHr (m)	ISH/ISP重量 ISH/ISP Weight (kg)
ISH/ISP50-32-160	0.55	1450	7	8.5	55	2.0	50/88
			10	8	60	2.0	
			12	7.5	59	2.4	
ISH/ISP50-32-160A	0.55	1450	6.5	6.5	55	2.0	50/88
			9	6	60	2.0	
			11	5.5	59	2.4	
ISH/ISP50-32-160B	0.55	1450	5.5	5.5	55	2.0	50/88
			8	5.2	60	2.0	
			10	5	59	2.4	
ISH/ISP50-32-200	0.75	1450	8.5	11.5	48	2.0	61/99
			12	10	56	2.0	
			14.5	8.5	54	2.4	
ISH/ISP50-32-200A	0.75	1450	7.5	10	48	2.0	61/99
			11	9	56	2.0	
			13	8	54	2.4	
ISH/ISP50-32-200B	0.55	1450	7	9	48	2.0	61/99
			10	8.5	56	2.0	
			12	7	54	2.4	
ISH/ISP50-32-250	2.2	1450	8.5	21	40	2.0	95/145
			12	20	47	2.0	
			14.5	18	45	2.4	
ISH/ISP50-32-250A	1.5	1450	7.5	19	39	2.0	82/132
			11	18	46	2.0	
			13	17	44	2.3	
ISH/ISP50-32-250B	1.1	1450	7	15	38	2.0	63/113
			10	14	45	2.0	
			12	13	43	2.3	
ISH/ISP65-50-160	0.55	1450	10.5	8.5	60	2.0	56/94
			15	7.5	65	2.1	
			18	7	66	2.5	
ISH/ISP65-50-160A	0.55	1450	8.5	7.5	60	2.0	56/94
			12	7	65	2.1	
			14.5	6.5	66	2.5	
ISH/ISP65-50-160B	0.55	1450	7.5	6.5	60	2.0	56/94
			11	6	65	2.1	
			13	5.5	66	2.5	
ISH/ISP65-40-200	1.1	1450	12.5	12.5	58	2.0	73/111
			18	11	63	2.1	
			21.5	10	62	2.5	
ISH/ISP65-40-200A	1.1	1450	12	11	58	2.0	73/111
			17	10	63	2.1	
			20.5	9	62	2.5	
ISH/ISP65-40-200B	0.75	1450	10.5	10	57	2.0	65/103
			15	9	62	2.0	
			18	8	61	2.5	
ISH/ISP65-40-250	3	1450	12.5	22	50	2.0	97/147
			18	20	56	2.1	
			21.5	19	55	2.5	
ISH/ISP65-40-250A	2.2	1450	12	21	43	2.0	95/145
			17	19	47	2.1	
			20.5	18	46	2.5	
ISH/ISP65-40-250B	1.5	1450	11	16	43	2.0	82/132
			16	15	47	2.0	
			19	14	46	2.4	
ISH/ISP80-65-160	1.1	1450	17.5	8.5	65	2.0	72/120
			25	8	71	2.0	
			30	7.5	70	2.4	
ISH/ISP80-65-160A	1.1	1450	16.5	7.5	65	2.0	72/120
			23.5	7	71	2.0	
			28	6.5	70	2.4	



性能参数 Performance parameters

(4P)

型号 Type	电机功率 Motor power (kW)	转速 Speed (r/min)	流量 Capacity (m³/h)	扬程 Head (m)	效率 Eff (%)	必须气蚀余量 NPSHr (m)	ISH/ISP重量 ISH/ISP Weight (kg)
ISH/ISP80-65-160B	0.75	1450	15	6.5	63	2.0	64/112
			22	6	69	2.0	
			26	5.5	68	2.4	
ISH/ISP80-50-200	2.2	1450	17.5	13	62	2.0	94/132
			25	12.5	67	2.1	
			30	11	66	2.5	
ISH/ISP80-50-200A	1.5	1450	16.5	12	62	2.0	86/124
			23.5	11	67	2.1	
			28	10	66	2.5	
ISH/ISP80-50-200B	1.5	1450	16.5	10	60	2.0	86/124
			23.5	9	65	2.1	
			28	8	65	2.5	
ISH/ISP80-50-250	3	1450	17.5	20.5	56	2.0	120/170
			25	20	61	2.1	
			30	19	60	2.5	
ISH/ISP80-50-250A	3	1450	16.5	18	55	2.0	120/170
			23.5	17	60	2.1	
			28	16	59	2.5	
ISH/ISP80-50-250B	2.2	1450	16.5	15	54	2.0	118/168
			23.5	14	59	2.1	
			28	13	58	2.5	
ISH/ISP80-50-315Z	7.5	1480	21	36	54	2.0	188/238
			30	35	57	2.1	
			36	34	58	2.4	
ISH/ISP80-50-315	5.5	1480	20	32	54	2.0	177/228
			28	30	57	2.2	
			33.5	28	58	2.5	
ISH/ISP80-50-315A	5.5	1450	17.5	27	53	2.0	177/228
			25	25	56	2.1	
			30	23	57	2.4	
ISH/ISP80-50-315B	4	1450	16.5	24	53	2.0	160/211
			23.5	23	56	2.1	
			28	22	57	2.4	
ISH/ISP100-80-160	2.2	1450	35	9	68	2.0	98/148
			50	8	75	2.2	
			60	7	73	2.6	
ISH/ISP100-80-160A	1.5	1450	33	8	66	2.0	90/140
			47	7	73	2.2	
			56	6	71	2.6	
ISH/ISP100-80-160B	1.5	1450	31	7	66	2.0	90/140
			44	6	73	2.2	
			52	5	71	2.6	
ISH/ISP100-65-200	3	1450	35	13	65	2.0	113/173
			50	12.5	74	2.1	
			60	11	72	2.5	
ISH/ISP100-65-200A	3	1450	33	12	64	2.0	113/173
			47	11	73	2.1	
			56	10	71	2.5	
ISH/ISP100-65-200B	2.2	1450	31	11	64	2.0	111/171
			44	10	73	2.1	
			52	9	71	2.5	
ISH/ISP100-65-250	5.5	1480	35	22	65	2.0	162/212
			50	20	70	2.1	
			60	18	69	2.5	
ISH/ISP100-65-250A	4	1450	33	17	63	2.0	145/195
			47	16	68	2.1	
			56	14	67	2.5	
ISH/ISP100-65-250B	4	1450	31	15	63	2.0	145/195
			44	14	68	2.1	
			52	13	67	2.5	
ISH/ISP100-65-315	11	1480	42	34	60	2.0	229/299
			60	32	66	2.2	
			72	29	64	2.6	



性能参数 Performance parameters

(4P)

型号 Type	电机功率 Motor power (kW)	转速 Speed (r/min)	流量 Capacity (m ³ /h)	扬程 Head (m)	效率 Eff (%)	必须气蚀余量 NPSHr (m)	ISH/ISP重量 ISH/ISP Weight (kg)
ISH/ISP100-65-315A	7.5	1480	39	28	60	2.0	191/261
			55	27	64	2.1	
			66	25	63	2.6	
ISH/ISP100-65-315B	7.5	1480	35	25	58	2.0	191/261
			50	24	63	2.1	
			60	22	62	2.6	
ISH/ISP125-100-200	5.5	1480	70	14	73	2.0	165/215
			100	12.5	79	2.2	
			120	10.5	78	2.6	
ISH/ISP125-100-200A	4	1450	63	10.5	72	2.0	148/198
			90	10	78	2.2	
			108	9	77	2.6	
ISH/ISP125-100-200B	4	1450	56	9.5	72	2.0	148/198
			80	8.5	77	2.2	
			96	8	76	2.6	
ISH/ISP125-100-250	11	1480	91	23	76	2.0	262/332
			130	20	79	2.1	
			156	17	78	2.6	
ISH/ISP125-100-250A	7.5	1480	77	18	75	2.0	225/295
			110	16	78	2.1	
			132	14	77	2.6	
ISH/ISP125-100-250B	7.5	1480	63	16	74	2.0	225/295
			90	14	77	2.1	
			108	13	76	2.6	
ISH/ISP125-100-315	18.5	1480	98	33	74	2.0	356/426
			140	30	79	2.2	
			168	27	75	2.6	
ISH/ISP125-100-315A	15	1480	84	30	73	2.0	309/379
			120	28	78	2.1	
			144	26	74	2.5	
ISH/ISP125-100-315B	15	1480	70	27	72	2.0	309/379
			100	26	77	2.1	
			120	24	73	2.5	
ISH/ISP150-125-200	11	1480	140	15	75	2.0	278/328
			200	13	81	2.7	
			240	10	80	3.2	
ISH/ISP150-125-200A	7.5	1480	126	12	74	2.0	240/290
			180	10	80	2.6	
			216	8	79	3.1	
ISH/ISP150-125-200B	5.5	1480	112	10	73	2.0	230/280
			160	8	79	2.5	
			192	7	78	2.9	
ISH/ISP150-125-250	15	1480	140	22	78	2.0	287/357
			200	20	82	2.5	
			240	18	81	3.0	
ISH/ISP150-125-250A	11	1480	126	18	77	2.0	270/340
			180	16	81	2.5	
			216	14	80	2.9	
ISH/ISP150-125-250B	11	1480	112	15	76	2.0	270/340
			160	14	80	2.2	
			192	13	79	2.6	
ISH/ISP150-125-315	30	1480	154	35	74	2.0	461/531
			220	33	80	2.5	
			264	30	79	2.9	
ISH/ISP150-125-315A	22	1480	140	29	73	2.0	392/462
			200	27	79	2.4	
			240	24	78	2.8	
ISH/ISP150-125-315B	18.5	1480	131	26	72	2.0	384/454
			187	24	78	2.2	
			224	21	77	2.6	
ISH/ISP150-125-400	55	1480	154	58	71	2.0	707/777
			220	55	76	2.3	
			264	52	75	2.7	



性能参数 Performance parameters

(4P)

型号 Type	电机功率 Motor power (kW)	转速 Speed (r/min)	流量 Capacity (m ³ /h)	扬程 Head (m)	效率 Eff (%)	必须气蚀余量 NPSHr (m)	ISH/ISP重量 ISH/ISP Weight (kg)
ISH/ISP150-125-400A	45	1480	147	53	70	2.0	595/665
			210	50	75	2.1	
			252	46	74	2.5	
ISH/ISP150-125-400B	37	1480	140	46	69	2.0	589/659
			200	44	74	2.1	
			240	41	73	2.5	
ISH/ISP150-125-400C	30	1480	126	40	69	2.0	534/604
			180	38	74	2.1	
			216	36	73	2.5	
ISH/ISP200-150-200	18.5	1480	196	17	76	2.6	382/432
			280	15	82	3.6	
			336	13	81	4.2	
ISH/ISP200-150-200A	15	1480	182	15	75	2.4	335/385
			260	13	81	3.5	
			312	11	80	4.1	
ISH/ISP200-150-200B	15	1480	182	13	74	2.4	335/385
			240	12	80	3.3	
			288	10	79	3.9	
ISH/ISP200-150-250	30	1480	280	23	77	3.3	481/551
			400	20	83	4.4	
			480	16	82	5.2	
ISH/ISP200-150-250A	22	1480	252	18	76	3.1	412/482
			360	16	82	4.2	
			432	12	81	5.0	
ISH/ISP200-150-250B	18.5	1480	231	16	75	3.0	404/474
			330	14	81	4.0	
			396	10	80	4.7	
ISH/ISP200-150-315	55	1480	280	38	77	3.0	778/868
			400	35	83	4.1	
			480	32	82	4.8	
ISH/ISP200-150-315A	45	1480	252	33	76	2.9	666/756
			360	30	82	3.9	
			432	27	81	4.7	
ISH/ISP200-150-315B	37	1480	231	31	75	2.6	660/750
			330	28	81	3.6	
			396	25	80	4.2	
ISH/ISP200-150-400	90	1480	280	57	77	2.8	1012/1102
			400	55	81	3.8	
			480	50	80	4.4	
ISH/ISP200-150-400A	75	1480	252	52	76	2.6	942/1032
			360	48	80	3.5	
			432	45	79	4.1	
ISH/ISP200-150-400B	75	1480	231	46	75	2.6	942/1032
			330	44	79	3.3	
			396	42	78	3.9	
ISH/ISP250-200-250	55	1480	420	27	78	4.4	810/900
			600	23	84	5.9	
			720	19	83	7.0	
ISH/ISP250-200-250A	45	1480	406	25	77	4.3	698/788
			580	21	83	5.7	
			696	17	82	6.8	
ISH/ISP250-200-250B	37	1480	350	22	76	4.0	692/782
			550	18	82	5.5	
			660	14	81	6.6	
ISH/ISP250-200-315	90	1480	448	41	78	4.2	1040/1130
			640	37	84	5.7	
			768	32	83	6.8	
ISH/ISP250-200-315A	75	1480	420	36	77	4.3	970/1060
			600	32	83	5.7	
			720	28	82	6.8	
ISH/ISP250-200-315B	75	1480	392	32	77	4.2	970/1060
			560	29	83	5.5	
			672	26	82	6.4	

注：不同品牌电机，重量有所不同，具体请咨询本公司销售人员。

Note: The weight is different if using different brands of motor. Please contact our sales for details.



如蒙洽询请指示下列各项

For further details, please fulfill the chart below.

客户 _____ 承办人员 _____
 Customer _____ Undertaker _____

工程名称 _____ 工程地点 _____
 Name of project _____ Address of project _____

电话 _____ 传真 _____
 Telephone _____ Fax _____

订购机型 _____ 订购数量 _____
 Type _____ Quantity _____

性能参数 Performance parameters	介质名称 Medium name			★ 介质温度 (C) Medium temperature		
	★ 流量 (m³/h) Capacity			★ 扬程 (m) Head		
	★ 进口压力 (MPa) Inlet pressure					
	轴封型式 Seal form	<input type="checkbox"/> 机械密封 (标准配置) Mechanical seal(standard)		<input type="checkbox"/> 其他 Other		
	主要部件材质 Major parts' material	泵体 Pump body	<input type="checkbox"/> HT250	<input type="checkbox"/> 304	<input type="checkbox"/> 其他 Other	
		叶轮 Impeller	<input type="checkbox"/> HT200	<input type="checkbox"/> 304	<input type="checkbox"/> 其他 Other	
		轴 Shaft	<input type="checkbox"/> 20Cr13	<input type="checkbox"/> 304	<input type="checkbox"/> 其他 Other	
	电源 Power	电压(V) Voltage			频率(Hz) Frequency	
		电机 Moter	型号 Type			功率(kW) Power
			防护等级 IP code			绝缘要求 Class of insulation
其他要求 Other requirement						
备注 Notes	1. 出厂标准配置不含地脚螺栓和吐出锥管。 The foundation bolts and discharge cone are not in the standard supply range. 2. 以上资料请尽可能填写完整, 以便于选择最佳机型, 项目前加注“*”者, 请务必填写。 Please fill in the parameter lists as complete as possible. The item with "*" must be filled.					



欢迎索取以下产品型录



泵系列

潜水泵系列 | 陆上泵系列 | 特种泵系列



搅拌推流系列

搅拌机系列 | 推流器系列



供氧曝气系列

曝气机系列 | 曝气盘系列 | 曝气管系列



风机系列

磁悬浮鼓风机 | 空气悬浮鼓风机 | 三叶罗茨鼓风机系列



污泥处理设备

带式脱水机 | 厢式压滤机 | 叠螺式脱水机 | 污泥干化设备 | 浅层高效气浮设备



智能化系列

智能设备 | 水务设备健康管理 | 水务系统工艺优化智联管理



反应器及套设备

芬顿反应系统 | MBR生物膜反应器 | 预制泵站 | 一体化污水处理设备



耗材药剂及相关设备

生物绳 | PAC 聚合氯化铝 | PAM 聚丙烯酰胺 | 泡药设备

GSD 的经营理念

G-Green 绿色 S-Safe 安全 D-Development 永续经营



川源

水处理系统专业合作伙伴

免费咨询电话

400-657-9066

数据来源：公司实验室数据及客户实际使用数据，具体使用环境不同，数据可能存在差异。

The data on the brochure is based on the laboratory testing data and customers' actual operation data in the past. The actual data may be different in different application conditions.

本型录内容如有变更，恕不另行通知。
We reserve the right to change content without notice.

川源（中国）机械有限公司版权所有 all rights reserved. CY-32

